

A P R I L 1 9 9 8

Macworld

Keep Your Mac in a Windows World

21-Page Special Report, p. 62

How to Share Data Files Easily:

- 25 Products Rated
- Expert Tips

Does NT Have What It Takes?

DOS Cards and Emulators Compared



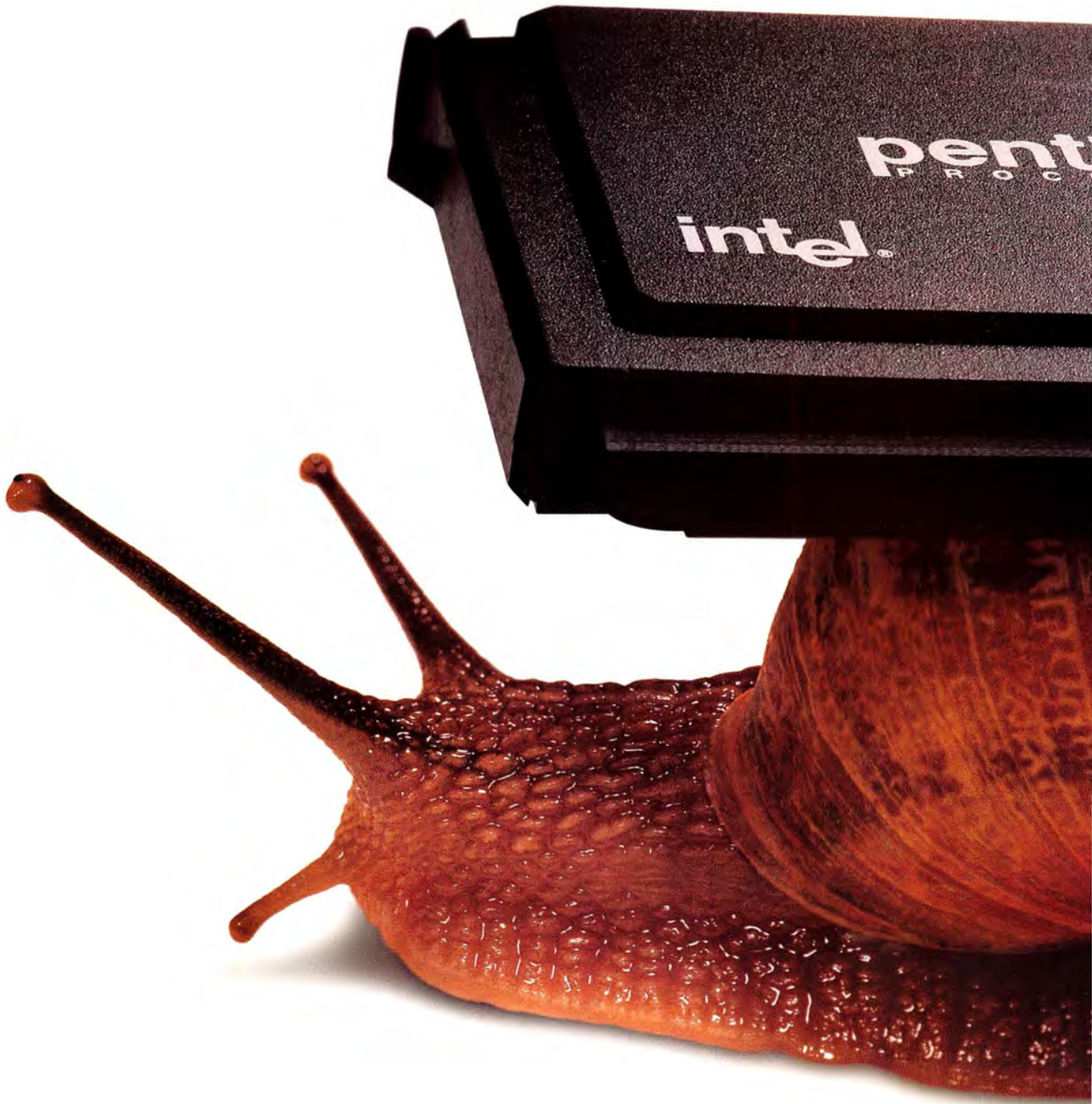

Some people think the Pentium II is the fastest processor in the world. Not quite

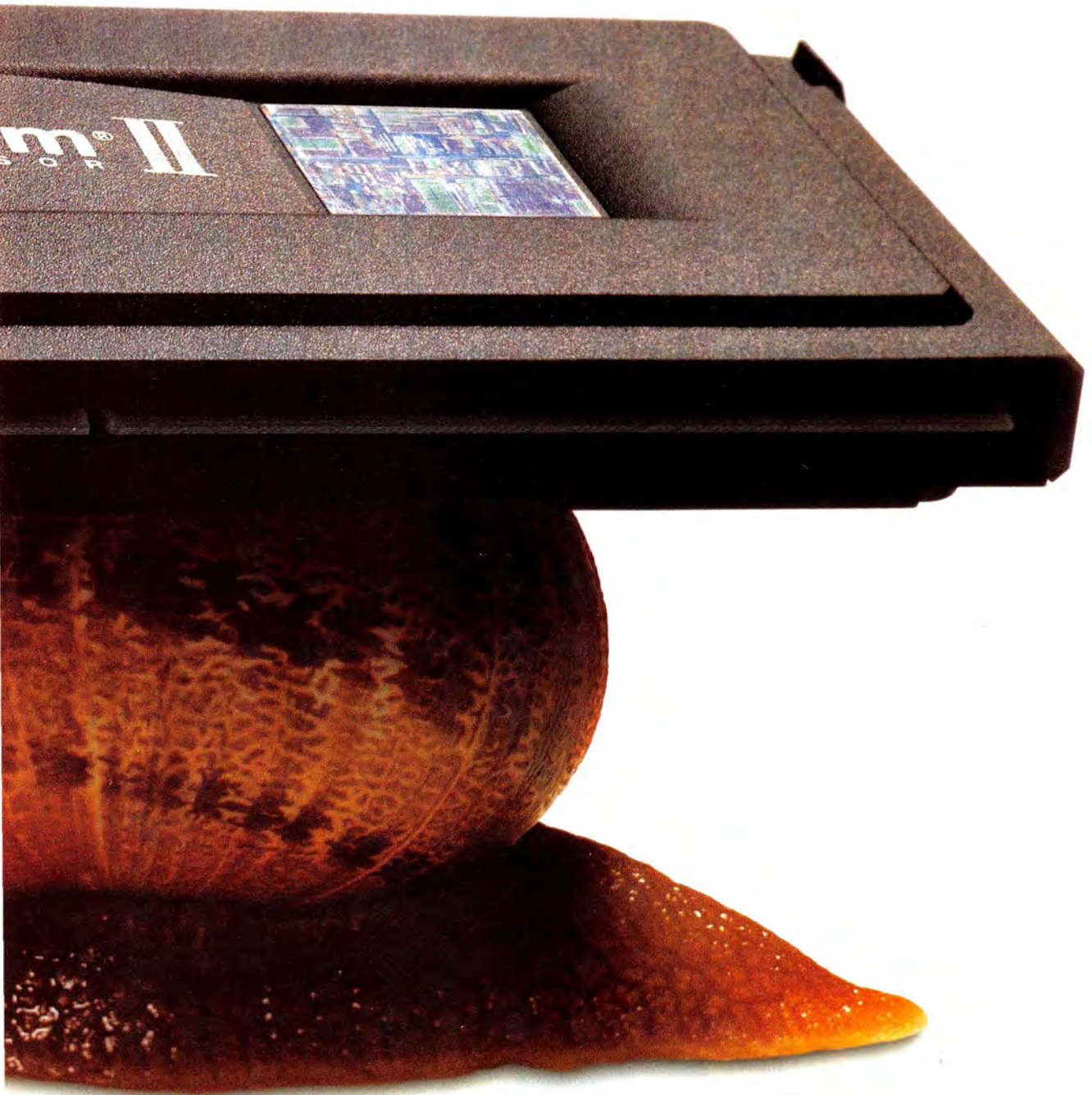

The chip inside every new Power Macintosh® G3 is up to twice as fast.* 🍏 Think different.™

Macworld

Incorporating MacUser

Cross-Platform Essentials

62 Save Your Mac!

BY HENRY BORTMAN How to make your Mac fit into an office full of Windows.

70 Mac Life Preservers

BY GALEN GRUMAN We tested 25 software solutions for navigating the cross-platform waters.

LAB TEST

73 Can the Mac Really Do Windows?

BY SUSAN SILVIUS See if hardware and software emulation products match up to a real PC.

78 Windows Beauty Tips

BY GALEN GRUMAN AND INGALL W. BULL III Get the look-and-feel of a Mac on a Windows workstation.

LAB TEST

81 Publishing Power Play

BY BRUCE FRASER Will an NT workstation win over Mac publishing pros?



You can't keep a good Mac down, page 62.

Features

LAB TEST

87 The Modem Showdown

BY RIK MYSLEWSKI Fourteen 56K modems: these bauds are built for speed, but how much?



FireWire ignites digital video, page 26.

Create

Print

103 Spot Color and Photoshop—Oil and Water?

BY DAVID BLATNER AND SANDEE COHEN *Macworld* fools Photoshop into working with spot colors.

Print

106 Spot Color and QuarkXPress 4

BY DAVID BLATNER QuarkXPress shines at letting you combine spot colors and preview the results.

Web

109 Watch This: Streaming Video on Your Web Site

BY JIM HEID Streaming technology frees Web video from its bandwidth bottleneck.

Motion

114 Distorted Reality—the Magic of Displacement Mapping

BY DAVID BIEDNY AND NATHAN MOODY Displacement mapping lets you produce your own reality-distortion fields.



We take NT to the publishing proving ground, page 81.

News

- 22 Apple Delivers QuickTime 3.0**
Updated multimedia-delivery system offers enhancements but awaits greater developer support.
- 23 Apple Dismantles Claris**
The new FileMaker, Inc., retains FileMaker Pro and Home Page. Other Claris products meet an uncertain fate at Apple.
- 23 The Year of Mac DVD?**
E4's CoolDVD brings this hot technology to the Mac.
- 24 Merger Wave Hits Plug-in Publishers**
Consolidation in the graphics-software market filters down to plug-in and XTension vendors.
- 26 FireWire Heats Up Digital Video**
Video-editing systems and DV camcorders incorporate new high-speed interface.

ON THE COVER

Photograph by Kevin Candland;
screen image by Douglas Fraser

Apple's hefty, high-quality new laptop, page 34.

Opinion

- 15 Letters**
- 19 The Vision Thing**
BY ANDREW GORE Power-PC positioned to blow the doors off Pentium.
- 178 The Desktop Critic**
BY DAVID POGUE Browsing for bargains: the Web offers sweet deals for penny-pinchers.
- 10 How to Contact Macworld**



Modem mania of the 56K variety, page 87.

Secrets

- 93 The HFS+ Survival Guide**
BY JOSEPH SCHORR Allocation reclamation: take back hard-disk space block by block.
- 97 Quick Tips**
BY LON POOLE Tips, tricks, and shortcuts.



Reviews

- 30** ★★★ Art Dabber 2.1.1;
★★ LivePix 1.1;
★★★ PhotoDeluxe 2.0
Low-end image editors
- 32** ★★★★★ QuickMail Office 1.0.2
POP3 e-mail server software
- 34** ★★★ PowerBook G3
Portable system
- 36** ★★★½ Dreamweaver
Web-page editor
- 38** ★★★★★ Epson PhotoPC 600;
★★★★½ Kodak DC210;
★★★★½ Olympus D-320L;
★★ Panasonic CoolShot KXL-601A
Midrange digital cameras
- 40** ★★★★★ Kiplinger TaxCut 1997;
★★★★½ MacInTax Deluxe 1997
Tax-preparation software
- 42** ★★★★★½ Bryce 3D
3-D-terrain generator
- 44** ★★★½ Creator2
Page-layout program
- 46** ★★★★★ HexWrench 1.0;
★★★★½ ImageVice 1.0;
★★ MC-P/CoCo and Channel 24
Color plug-ins for Adobe Photoshop
- 48** ★★★★★ VST Zip 100
PowerBook Zip drive
- 50** ★★★★★ PhotoTools 2.0
Adobe Photoshop plug-ins
- 52** ★★★ Insider Updates 2.01;
★★★★½ Shaman Update Server
Personal Edition 1.2
Software-updating services
- 54** ★★★★★½ Commotion 1.1
Video-painting software
- 54** ★★★★★ NetCloak 2.5
Internet utility
- 56** ★★★★★½ PowerPrint 4.0
PostScript interpreter for ink-jets
- 56** ★★★ ClockWork
Personal information manager
- 58** ★★★ CD-Copy 2.0
CD-ROM-duplication utility
- 60** ★★★★★½ Ray Gun
Real-time sound processor



**If you wrestle with color professionally,
get a match with the Blue Hood.**

Introducing the La Cie Electron21™, the monitor with the color-enhancing Blue Hood.

Circle 52 on reader service card

LACIE



AnthroCarts!®

Configure them the way you want!



Lifetime Warranty • Dozens of Shapes and Sizes
Over 75 Accessories • Tough as Nails • Order Direct!



Call for a free Catalog:

800-325-3841

6:00 AM to 6:00 PM PST, M-F

ANTHRO®

Anthro Corporation®
Technology Furniture®
Tualatin, OR 97062
Fax: 800-325-0045
Japan: 03 (Tokyo)-3947-2735
www.anthro.com



Since 1984. Prices from \$299. GSA contract. Available for OEM applications.

Macworld

EDITOR IN CHIEF Andrew Gore
EXECUTIVE ASSISTANT Patricia Carberry-Harris

EDITORIAL

EDITOR Galen Gruman
EXECUTIVE EDITOR Carol Person
SENIOR EDITOR/NEWS Stephen Beale
SENIOR EDITOR/FEATURES Elizabeth Dougherty
SENIOR EDITOR/REVIEWS Anita Epler
SENIOR EDITOR/DEPARTMENTS Nancy Peterson
SENIOR TECHNOLOGY EDITOR Henry Bortman
SENIOR ASSOCIATE EDITORS Cathy E. Abes,
Linda Comer,
Jason Snell,
Katherine L. Ulrich
ASSOCIATE EDITORS Allyson Bates,
Scholle Sawyer,
Brooke C. Wheeler
EDITORIAL LAB COORDINATOR Shawn S. J. Sadler

CONTRIBUTING EDITORS

David Biedny, Christopher Breen, Bruce Fraser, Ted Landau,
Deke McClelland, David Pogue, Lon Poole, Joseph Schorr,
Franklin N. Tessler

LAB

LAB DIRECTOR Jeffrey S. Pittelkau
ASSISTANT LAB DIRECTOR Susan Silvius
SENIOR LAB ANALYSTS Jeffy K. Milstead,
Kevin Mitchell
ASSOCIATE LAB ANALYST Gil Loyola

COPY EDIT

MANAGING EDITOR Claire H. Breen
COPY CHIEF Paul-Michael King
SENIOR COPY EDITORS Elissa Rabellino,
Jon Zobenica

ART AND DESIGN

DESIGN DIRECTOR Eleanor Leishman
ART DIRECTOR Sylvia Chevrier
ASSOCIATE DESIGNERS Martha Katt,
Michael Rattary
DESIGN ASSOCIATE Jackie Goodman

Juice Up Your Mac With Windows® Compatibility!



Squeeze OrangePC® into Your Apple!

Our newest Windows® compatibility card, the OrangePC® 550, when armed with the AMD-K6™ or Intel® Pentium 233 MMX™, provides the highest performance solution on the market. To demonstrate the phenomenal power of real hardware-based Windows® compatibility, the OrangePC was benchmarked against a software emulation competitor. Using the Ziff-Davis Business Winstone benchmark running on a Power Macintosh G3, OrangePC ran 7 times faster. 700% more performance, now that's some serious juice!

The new OrangePC 550 has a stunning set of exclusive features including accelerated 3D video, 3D wavetable sound, 512 KB L2 cache, and 4 MB of video SGRAM – all leading edge stuff!

And the OrangePC's software application shows the Mac environment and the Mac screen to display the Windows® environment in a Mac window. It's like a "picture in picture" on your TV!

Windows® screen to show the Mac environment and the Mac screen to display the Windows® environment in a Mac window. It's like a "picture in picture" on your TV!



The Technical Specs: OrangePC is available in 12" or 7" PCI cards (7" cards support "all-in-one" Macs); up to 233MHz MMX Intel, Cyrix® or AMD-K6; expandable RAM to 256 MB; up to 512 KB pipeline burst L2 cache on model 550; parallel port (for PC dongles); 2 high speed serial ports; game port; 3D wavetable sound in/out; 2/4MB video memory.

Now available from:

MacPowerhaus
"The Cross-Platform Connection"
(800) 615-3183

MICRO CENTER

Computer Town
www.computertown.com
(800) 613-0622

Orange Micro
inc.

"18 Years of Innovation and Excellence"
1400 N. Lakeview Ave., Anaheim, CA 92807
(714) 779-2772
www.orangemicro.com

Did you get your ?

Macworld

PRESIDENT AND CEO Colin Crawford
 ASSISTANT TO THE CEO Sharon Sanderson
 CHIEF FINANCIAL OFFICER Stephen Daniels
 FINANCIAL ANALYST Eos de Feminis
 VICE PRESIDENT OF HUMAN RESOURCES Shelly Ginenthal
 EMPLOYEE RELATIONS MANAGER Marisa Chow

Macworld is a publication of Mac Publishing, L.L.C.

Available Now!

VST Zip™ 100 Drive

for your:
**G3, 3400,
 1400
 and 190/5300
 Series PowerBooks®**



VST
 TECHNOLOGIES
 Incorporated

Available At:



MacMall
 1-800-222-2808

MICRO CENTER
 THE COMPUTER DEPARTMENT STORE®

MacConnection
 800-998-0040

ClubMac
 1-800-258-2622

The Mac Zone
 1-800-248-0800
 MV02

Mac WAREHOUSE
 1-800-255-6227

Questions? Call VST @: (978) 263-9700

Iomega, the Iomega logo, Zip, and The Capacity To Do More are trademarks of Iomega Corporation. All other trademarks are property of their respective holders. Iomega patents protected by patent applications pending in the US and other countries.

Circle 73 on reader service card

DISPLAY ADVERTISING SALES

VICE PRESIDENT, SALES, & PUBLISHER Matt Sweeney
 NATIONAL SALES DIRECTOR Steve Plevin (415/978-3138)
 SALES/MARKETING COORDINATOR Nancy Galanty (415/978-3124)
 WESTERN ADVERTISING DIRECTOR Karl Elken (415/978-3155)
 ACCOUNT EXECUTIVE Christine Wong (415/978-3192)
 NATIONAL ACCOUNTS MANAGER Liz Pabón (415/978-3257)
 ACCOUNT EXECUTIVE Jessica Ross (415/267-1799)
 ADMINISTRATIVE ASSISTANT Jesse Wadhams (415/975-2619)
 NATIONAL ACCOUNTS MANAGER Sara Culley (970/327-4499)
 ACCOUNT EXECUTIVE Margaret Level Green (415/267-4577)
 EASTERN ADVERTISING DIRECTOR Cynthia Ramsey (973/243-1197)
 NATIONAL ACCOUNTS MANAGER Paul Bonarrigo (508/533-4020)
 ACCOUNT EXECUTIVE Jo Zotterelli (516/277-4134)

RESEARCH

SENIOR RESEARCH ANALYST Phillip Hibbert

MARKETING

VICE PRESIDENT, MARKETING Vickie Welch
 MARKETING MANAGER Renée Bula
 SENIOR TRADE SHOW AND EVENTS MANAGER Anna Noetzel
 CREATIVE SERVICES MANAGER Kelvin Gee

PRODUCTION

VICE PRESIDENT OF MANUFACTURING Anne Foley
 PRODUCTION DIRECTOR Cynthia Neustadt
 ASSISTANT PRODUCTION MANAGER David W. McAferty
 MANUFACTURING TECHNICAL DIRECTOR Clayton Haberman
 DIGITAL AD COORDINATORS Brian Mullin, Mark Van Slyke
 AD SALES COORDINATOR Rick Sandoval

ONLINE

PUBLISHER Jeff Julian
 NATIONAL ACCOUNTS MANAGER Ed Ramirez
 ACCOUNTS MANAGER Nicholas Harvey
 MEDIA COORDINATOR Jamila Johnson
 EDITOR James S. Bradbury
 SHAREWARE EDITOR Philip W. Dyer
 ONLINE PRODUCTION EDITOR Roxanne Gentile
 ASSISTANT CONTENT ENGINEER Jessica Graves



what you do:

redraw, stress
 scroll, stress
 render, stress
 rasterize, stress
 model, stress
 filter, stress . . .

what we do:

make all of the
 above happen
 faster than you've
 ever dreamed.
 (without the stress)

From the makers of TwinTurbo® come the powerful, perfectly balanced graphics board solutions you've been hoping for. ix3D boards eliminate those long, gut-wrenching moments spent waiting for your computer to execute the 2D, 3D and video functions on which your creativity depends. ix3D boards are powered by IXMICRO's new TwinTurbo 128-3D for raw graphics power you never thought possible. Look for us at your favorite retailer, or check out our Web site for more details. And stop stressing.



ix3D Ultimate Rez

for graphics experts who need to drive today's largest monitors at extreme resolutions and color depths - while maintaining fast, ergonomic refresh rates. Ideal for 2D, 3D graphics and CAD applications like Adobe Photoshop, Quark Express, Lightwave 3D, and Microstation.



ix3D Pro Rez

optimizes the performance and value for users who need uncompromising graphics power and who routinely operate 17-19" monitors at moderate resolutions like 1152 x 870. Video upgrade available.



ix3D Mac Rocket

provides home and office users with a blast of pure 128-bit 2D and 3D graphics power, adding speed and performance to all common operations. Video upgrade available.

ix3D™

www.ixmicro.com

©1997 IXMICRO. TwinTurbo is a registered trademark of IXMICRO. All rights reserved. All other product and company names are property of their respective owners.

Circle 150 on reader service card



IXMICRO™
[WWW.IXMICRO.COM](http://www.ixmicro.com)

work hard and fast. do it with style.

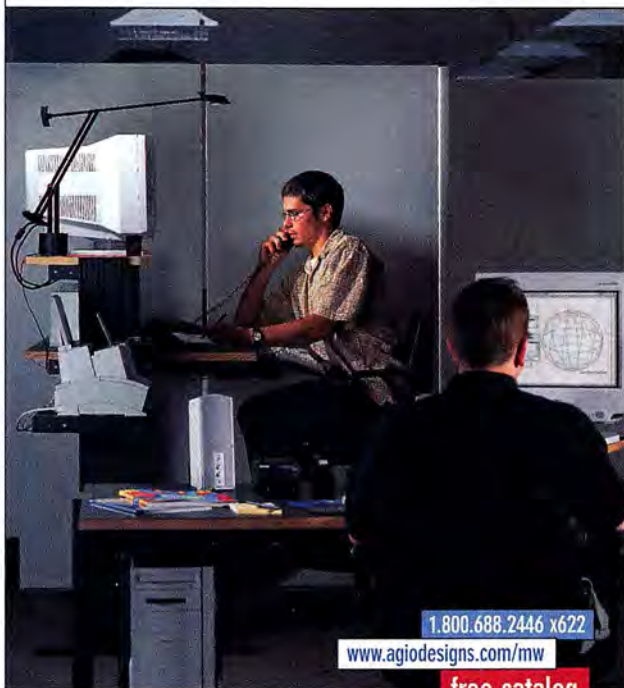

1.800.688.2446 x622

www.agiodesigns.com/mw

free catalog

AGIO DESIGNS™
furniture for the way you do business

THE ONLY ONE



We upgraded Apple's desktop G3 to 384MB at MACWORLD EXPO '98. We can upgrade you too! With our breakthrough low profile design, Legacy Electronics™ has created the only 100MHz 128MB SDRAM DIMM available today that meets the specifications for the desktop G3.

Now, this design is available to you. Call Legacy Electronics today and find out what's next.

LEGACY
ELECTRONICS, INC.

Dealer Inquiries Welcome ▲ 888/466-3853 ▲ www.legacyelectronics.com

Circle 35 on reader service card

Macworld

HOW TO CONTACT MACWORLD

Subscription Questions

Phone	303/665-8930
Fax	303/604-7455
U.S. Mail	Subscription Services P.O. Box 54529, Boulder, CO 80322
America Online	Keyword Macworld
World Wide Web	www.zdnet.com/zdsubs/macworld/service

Reprints and Permissions

You must have permission before reproducing any material from *Macworld*. Write to *Macworld*, Reprints and Permissions, 501 Second St., San Francisco, CA 94107; include a phone number. To order reprints of your company's editorial coverage, call 800/217-7874.

Back Issues of Macworld

Back issues (subject to availability) are \$7 per issue for U.S. delivery (\$12 overseas); prepayment in U.S. funds is required. Send check or money order to Back Issues Department, Ziff-Davis Inc., P.O. Box 53131, Boulder, CO 80322-3131.

Macworld in Microfilm

Macworld is available on microfilm and microfiche from UMI, 300 N. Zeeb Rd., Ann Arbor, MI 48106-1346; 313/761-4700.

Macworld Editorial

The editors of *Macworld* welcome your tips, compliments, or complaints. We are unfortunately unable to look up stories from past issues; recommend products; or diagnose your Macintosh problems by phone, e-mail, or fax. Contact Apple toll-free at 800/538-9696, ext. 500, for information on user groups in your area.

Our offices are located at 501 Second St., San Francisco, CA 94107; 415/243-0505, fax 415/442-0766.

LETTERS TO THE EDITOR Direct all comments and suggestions regarding any aspect of the magazine to letters@macworld.com. Due to the high volume of mail received, we can't respond personally to each letter. We reserve the right to edit all submissions. All letters published in *Macworld* or *Macworld Online* become the property of *Macworld*.

QUICK TIPS Send your questions or tips on how to use Mac computers, peripherals, or software to the attention of *Macworld*, *Quick Tips*, 501 Second St., San Francisco, CA 94107; fax 415/442-0766; e-mail quicktips@macworld.com. Please include your name, address, and telephone number.

Macworld is a publication of Mac Publishing, L.L.C. *Macworld* is an independent journal not affiliated with Apple Computer, Inc. *Macworld*, *MacUser*, *MacWeek*, *Macworld Interactive*, *Macworld Shopper*, *MW Lab*, *MW Shopper*, *The Desktop Critic*, *Expert Graphics*, *Quick Tips*, *Star Ratings*, *Buyers' Tools*, *Streetwise Shopper*, and *Conspicuous Consumer* are registered trademarks of Mac Publishing, L.L.C. *Apple*, the *Apple logo*, *Mac*, and *Macintosh* are registered trademarks, and *MacLetter* and *PowerBook* are trademarks, of Apple Computer, Inc. Printed in the United States of America. Copyright © 1998 Mac Publishing, L.L.C. All rights reserved.



As Extreme As you Want to Be!



Go to extremes on the industry's hottest Windows NT® and Intel Pentium® II processor-based desktop machine for graphics professionals – the ExtremeZ™ Graphics Workstation from Intergraph Computer Systems. It's the only MacFriendly™ NT workstation available. Look at what the ExtremeZ delivers:



- **Superior graphics and blazing performance** for 2D and 3D design, multimedia, and prepress, especially for transferring files across networks in highly productive workflows!
- **Mac/NT connectivity** for integrating the ExtremeZ into existing environments, providing full peer-to-peer connectivity to Mac systems through AppleTalk!
- **Power to read/write Mac-formatted media** on an NT box!
- **Easy-to-use** features and commands and a great **out-of-box experience** with prebundled apps and lots of other options!
- **Platform for graphics applications you now use** – Adobe Photoshop®, Illustrator, QuarkXPress™, Painter, FreeHand, plus many more – and they look and feel the same regardless of operating system!
- **Service and support** from a dedicated publishing team!

Call now for more information on Intergraph's Extreme Graphics Machines or for the name of a reseller near you.

1-800-763-0242

www.intergraph.com/publishing



Intergraph and the Intergraph logo are registered trademarks of Intergraph Corp. The Intel Inside Logo and Pentium are registered trademarks and MMX is a trademark of Intel Corp. Microsoft and Windows NT are registered trademarks of Microsoft Corp. Intergraph is not responsible for inadvertent errors. Copyright 1998 Intergraph Corp. Huntsville, AL 35894-0001. MC980091.



INTERGRAPH
COMPUTER SYSTEMS

Your Mac



What Newer Technology does is simple: we sell products that make Macs™ faster and better.

Many times upgrading your existing Mac is smarter than buying a new one. For instance, if you're looking for the absolute fastest Mac you can own, then you have to buy a MAXpowr™ G3, because no shipping system from

Apple can outperform it. Or if you're looking for a lot of bang for

the buck, the MAXpowr Citation is the way to go. It lets you replace your older processor with a fast 604e for as little as \$359*. That's right, you can bring your machine out of the stone-age and make it as fast as the new top-of-the-line Macs without spending tons of cash for a new system.

Check Out These Performance Specs	
MAXpowr G3 275	1077
PowerMac G3 266	895
MAXpowr G3 266	978
PowerMac G3 233	785
MAXpowr G3 250	800
PowerMac 9600/300	733

Call 1-316-943-0222 for more info or surf to www.newertech.com • email: info@newertech.com

Your Mac
With
A Newer
Upgrade



After all, your basic system is still fine; technology has just left
MW ★★★★★ your processor in the dust. So keep the box, save
the cash, and just give your Mac a brain transplant.

Plus, with Newer Technology you're buying from a company
you can trust. We're not some dinky company being run out of a
garage. In fact, we've been engineering and selling **Macworld**
products that make Macs better since 1984. So you can be

assured that you're going to get top-of-the-line products, great
service, knowledgeable support and total compatibility.

So come by our website and see which processor is right for
your particular machine. No matter what kind of a Mac **◆◆◆◆**
or Mac-compatible you're using, Newer Technology has a product
that can make it better.

Let us prove that sometimes Newer™ is better than new.



Sometimes Newer™ Is Better Than New.

Circle 83 on reader service card

Set Your World in Motion



New Bryce 3D lets you create incredibly realistic, fully animated 3D worlds!

Real-world atmospheric effects. Set every part of your 3D world in motion, including clouds, the phases and positions of heavenly bodies, star fields, and fog and haze that react realistically to light intensity and color.

Complete animation control. Scale, resize, or position object paths in seconds, then link them to create motion. Set camera and lights to track objects automatically.

Unbelievably realistic terrains. Paint height values for peaks, valleys, plateaus, and erosion, then animate the entire scene. For instant results, check out the real-time, rotating 3D preview.

Fully animatable materials and textures. Picture brick melting into water or a snow capped mountain emerging from winter into spring—now you can make it happen!

Get Bryce 3D and set your world in motion, the easy way!



Bryce 3D

IT MOVES

Attention Bryce Owners!
Upgrade Today for Only \$99

800.846.0111 Dept. 126
www.metacreations.com



MetaCreations.

The Visual Computing Software Company

Circle 5 on reader service card

Letters

Missing Andy, Bob, Chris, and Jim

I WAS DISAPPOINTED TO SEE THAT Andy Ihnatko will no longer be writing for your magazine ("Transitions," January 1998). You are losing one of the best columnists of both *Macworld* and *MacUser*. Andy's column was unique, a nice change of pace in the middle of all the news, reviews, and oh-so-serious columnists discussing the oh-so-serious state of Apple and the Mac.

Andy's column allowed for humor in the magazine. Face it—without some levity, *Macworld* might as well be one of those dime-a-dozen PC business magazines that just happens to cover the Mac.

You have succeeded in one thing: I can now read *Macworld* from cover to cover without cracking a smile. Congratulations, I guess.

DAVID GOFF
San Antonio, Texas

ANDY IHNATKO IS ONE OF THE FEW technically savvy people that I have read who is intentionally humorous. Every month, the first page I turned to was Andy's column. After the merger of *Macworld* and *MacUser*, I was relieved to see that he was not lost in the shuffle. Now that I find he is a goner, I am very distressed. He will be very sorely missed by a lot of fans.

RICHARD BEIRNE
via *Macworld Online*

WHEN I ASKED MY NEW DOWNSTAIRS neighbor where she was from and she said, "the former Yugoslavia," I wondered what it would be like to be from a "former" place. As a member of the Mac community, I'm starting to get an idea.

The bemused possessor of a "former" Power Computing box, I also have a sub-



scription to the "former" *MacUser*. With this issue I learn that Andy Ihnatko and the team of Bob LeVitus and Christopher Breen ("Help Folder," January 1998) are about to become "former" columnists. Bummer. These guys have style, know a lot, and are irreverent without becoming tedious about it. They brought a little more fun into my life. I'm sorry to see them go.

LUCY TINKCOMBE
Boston, Massachusetts

I'M SORRY TO SEE THAT JIM HEID IS leaving *Macworld*. There are those of us out here in Macdom who have been with him since the start, and will miss him. Jim's articles have always been timely and informative. He has helped us learn, and it's been appreciated.

MIKE CHICHESTER
Spring Hill, Florida

We, too, will miss the columns from these contributors. But look for their continued contributions

in other sections of the new Macworld. A merger is never easy and there wasn't room for everyone, but we're doing our best to keep the original MacUser and Macworld contributors involved in the new Macworld.—Ed.

Top-Notch Typography

KATHLEEN TINKEL'S "10 TYPOGRAPHICAL Blunders" is excellent (January 1998)! Her article is invaluable for people in my position, untrained in page design but responsible for helping make it look better. We publish four magazines, and I am sure we are committing several of these blunders. Thanks!

DEREK NELSON
Norfolk, Virginia

SET AND POLICE TYPE STYLES AT the *Watertown Daily Times* in New York. Kathleen Tinkel made one blunder in her article: you can't generalize that it's better to set type ragged. Studies have found that it's far easier for readers to deal with lines of the same length—justified—if the text goes on at length without interruption. Newspaper news stories and novels are almost invariably set justified.

On the other hand, in a treatment such as a newspaper feature, magazine article, or art book where the text is broken by pictures, ragged type is attractive and acceptable.

MARK HOLBERG
Watertown, New York

WHAT A WONDERFUL ARTICLE! I wish I could have shown it to a couple of hundred clients over the years. Kathleen Tinkel does a superb job of pointing out many of the pitfalls that await the novice.

continues

CORRECTIONS

- *The \$1,999 base-model Power Mac G3/233 system ("Apple's Next-Generation Systems," January 1998) does not include a modem; the modem is \$150 extra. The G3 tower model has only three slots for RAM, not six. You can still install up to 384MB of RAM, due to the tower case's allowing taller 128MB RAM modules.*

I would add two more to the list: First, be conservative in how many fonts you use in a document. If you use more than three fonts on a page, you should have a pretty good reason. The second is one of my pet peeves, a mistake I see a lot of pros making: before you use all caps, be sure it's appropriate for your font. Old English and italic faces, for example, should never be set in all caps.

TIM DONOHOE
Grand Rapids, Michigan

Quicken Still Falls Short

WENDY SHARP'S REVIEW OF INTUIT's Quicken Deluxe 98 (January 1998) gave it an overall positive rating. However, the Investment portion of the program is still filled with bugs and problems that have existed since Quicken 4. Quicken does not know the difference between options, bonds, mutual funds, stocks, or money-market funds. Major inadequacies in Quicken, such as its inability to report capital gains and losses for any short sales or covered call writes and its incorrect calculation of ROIs, have plagued it for years. Intuit has been aware of these investment issues and still has not fixed any of them.

MONTY LEE
via Macworld Online

EVERY REVIEW OF QUICKEN FOR the past three years overlooks one feature where it falls short: Cash Flow Forecasting. Quicken clumsily bases cash flow on the Calendar instead of the Budget, necessitating re-entry of all your information. Cash-flow forecasting based on the budget is very useful for maintaining checking balances and preparing for investing or spending.

BILL BRAAK
Colorado Springs, Colorado

Cultivating a New Generation

MY FIVE-YEAR-OLD DAUGHTER AND I were watching television when the Emergency Broadcast System test came on. My daughter immediately grabbed the remote and turned the TV off and back on. "It bombed and we have to restart it," she informed me.

She is a real Mac child—I guess that's why I put up with her constantly changing the desktop pattern to teddy bears.

JOHN AFFLECK
Maple Ridge, British Columbia, Canada

FOR OUR HOMEWORK ASSIGNMENT in my ninth-grade computer class we had to find any article remotely connected to computers and enter it for typing practice. When I saw David Pogue's article, I knew my search was over (*The Desktop Critic*, January 1998).

Unfortunately, my school uses PCs. Although normally I would never lower myself to using anything other than a Mac, I am forced by this country's educational system to submit myself to torture by means of Windows 95.

When I received this assignment I saw it as a chance to stand up for what I believe in. My class, including my teacher, got a good laugh out of my article, and it is with joy that I say she may finally be seeing the light. In the meantime I will continue to read David Pogue's articles in hopes of inspiring other poor lost souls in PC land to return to the place they know they belong.

DEVORA WHITMAN
New Haven, Connecticut

Genealogy Gripes

I DIDN'T KNOW WHETHER TO LAUGH or cry at the reviews of Family Tree Maker Deluxe and Ultimate Family Tree Deluxe (January 1998). While I have never used either, I had purchased Ultimate Family Tree at what I thought was a bargain price of \$18.05, until I opened the box. I decided to laugh and continue using Personal Ancestral File 2.3.1, developed by the Church of Jesus Christ of Latter-Day Saints. While the Mac version leaves several things to be desired, it's right up there with Leister Productions' Reunion.

SHARRON STANDIFER ASHTON
Norman, Oklahoma

MACWORLD'S REVIEW OF GENEALOGY software was informative but failed to mention one feature important to anyone seriously into genealogy: the ability to save the data in GED format. This standard format is used for sharing information between different computers and programs. I should also mention a good shareware program, Gene 4.2, from Diana and David Eppstein. It may not have all the bells and whistles of Reunion, but it has easy data entry; saves in HTML and GED formats; and has most of the same features, including reports, charts, and the ability to link pictures to cards. For the shareware price of \$15 it's a great bargain and a good place to start for anyone who finds the price of Reunion a bit steep.

KENT LORENTZEN
Jacobson, Minnesota

OS 8 Ain't So Great

EARLIER IN THE YEAR I BOUGHT A Performa 6400/200 and installed Mac OS 8. One week later my system started its ominous, slow descent into computer hell. First it wouldn't load the final five extensions upon start-up, and then it wouldn't boot altogether. I did the usual diagnostics, but to no avail.

When I called Apple Support they apologetically told me that OS 8 has a major problem with the Performa drivers. They mailed me a free update, and all was forgiven—until now. The slow descent has started again. Am I going to need to update my drivers every time something goes wrong with this piece of technology? Why didn't Apple plainly state this problem to people who bought the OS 8 upgrade? I think I'll dump System 8 for good ole 7.5.

TERY HOLLY
via Macworld Online

Letters should be sent to *Letters*, Macworld, 501 Second St., San Francisco, CA 94107; via fax, 415/442-0766; or electronically via CompuServe (70370,702), MCI Mail (294-8078), America Online (keyword Macworld), AppleLink (Macworld1), or the Internet (letters@macworld.com). Include a return address and daytime phone number. Due to the high volume of mail received, we can't respond personally to each letter. We reserve the right to edit all letters. All published letters become the property of Macworld. **m**

The World's First Do-It-Yourself Ad.

Rather than try and sell you on Canvas 5, we invite you to sell yourself with a 30 day free trial offer.



CANVAS 5

Only one person knows what you want in a graphics program: you. So go on — try Canvas 5 (fully functional, not some weenie sampler) for 30 days, free. If you like, you buy. If you don't, you don't. Canvas 5 has everything you need to tackle any graphics task, from technical drawing and photo editing, to desktop publishing and web design. All fully integrated. All easy to use. And all yours for the asking. Call 1.800.6CANVAS (622-6827) or 305.596.5644 ext. 2, and ask for your free Evaluation CD or visit our web site at www.deneba.com/macworld/ to download it gratis. And if you've already sold yourself, visit your favorite reseller or call us and pick up a copy today.

© Copyright 1997 Deneba Software. Limited time offer valid only in North America. This ad was made using nothing but Canvas 5. Any questions?



Circle 57 on reader service card

NEW VERSION!

MiniCAD[®] 7

Windows[®]/Macintosh[®]
The Easiest, Most Cost-Effective Way to Design

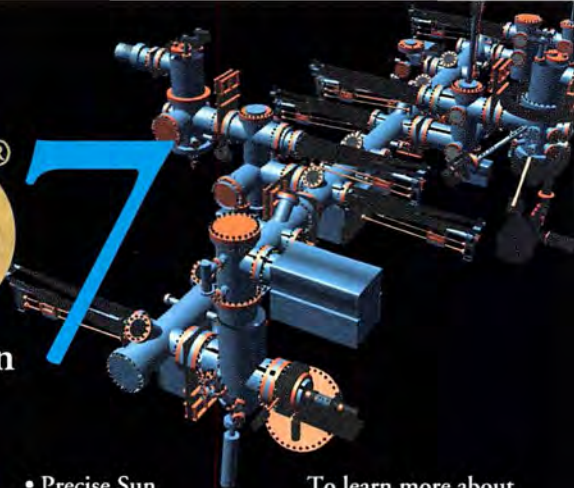

For more than a decade, professionals seeking an out-of-box CAD solution have selected the award-winning MiniCAD. This stand-alone program lets you create everything from precise working drawings to sophisticated client presentations

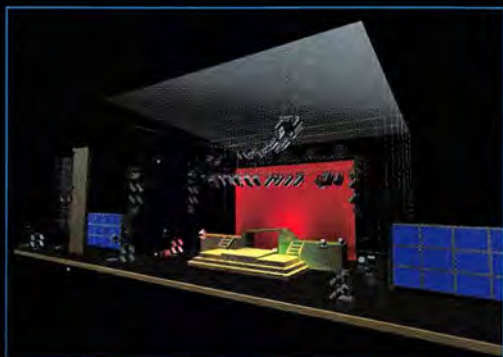

- Precise Sun Positioning
- Expression Evaluation Inside Textboxes
- Automated Databases/Spreadsheets
- Multi-Decimal Dimensioning
- Rotatable Grid and Customizable Coordinate System
- Plus Dozens of Performance and Interface Enhancements

To learn more about MiniCAD's extensive feature set and why the program has been called "the easiest, most cost-effective way to design," call 1-888-MINICAD or visit our Web site: www.diehlgraphsoft.com MiniCAD 7, which retails for a suggested price of \$795, comes with 18 months of FREE Tech Support and a 30-Day Money-Back Guarantee!

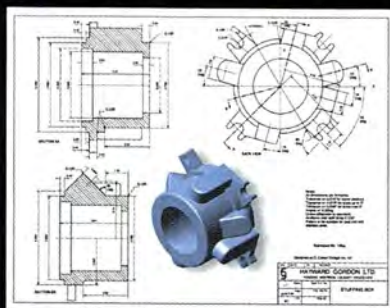

tries—multi-decimal accuracy for precise drafting, a built-in database/spreadsheet to track costs and materials, extensive

Now this total CAD solution speeds your design process with these new features:

- True 3D Boolean Solid Modeling
- DWG and DXF Import/Export
- Dual-Unit Dimensioning
- Auto Wall Framing
- QuickDraw 3D Rendering
- Associative Hatching
- Automatic Wall Joining
- Next-Generation SmartCursor

to extensive materials lists and cost estimates.

As always, MiniCAD 7 offers the same core features that have made it the program of choice for design professionals in more than 80 coun-

tries—multi-decimal accuracy for precise drafting, a built-in database/spreadsheet to track costs and materials, extensive library of industry-specific symbols, cross-platform compatibility (Mac and Windows), and a macro programming language for automating complex and routine tasks.

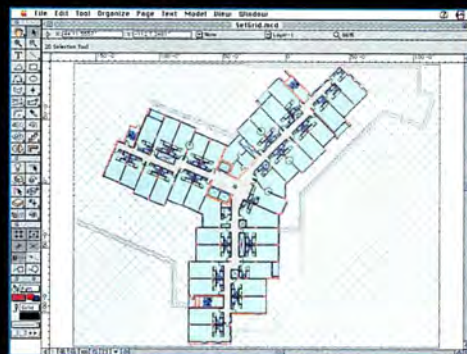

MiniCAD 7—The only thing small is the price.



Circle 46 on reader service card

MiniCad is a trademark of Diehl Graphsoft, Inc. All other brands and product names are trademarks of their respective holders.

Look, Up in the Sky . . . It's SuperChip!

THE RUMORS OF THE POWERPC'S DEATH HAVE BEEN GREATLY EXAGGERATED

SOMETIMES THE MOST damning insult is the one that comes dressed as a compliment. Take the recent commentaries by PC pundits about the PowerPC microprocessor architecture that the Power Mac is based on. The pundits believe that, despite its current speed and price advantages over the Pentium, the PowerPC's decline into irrelevance is inevitable.

One analyst went so far as to say that the PowerPC 750, also known as the G3, delivers impressive performance *only* when you take its price into consideration . . . as if this were a bad thing! His ultimate point was that Intel would, in the not-too-distant future, be delivering processors that could meet or beat the 750.

OK, I can play by those rules. Let's talk about the future. Let's talk about speed so fast that companies building products using the PowerPC are going to have to add an extra zero to the names of their products.

By the time you read this, PowerPC partner IBM will have announced a major breakthrough in PowerPC technology. By next year, there will be PowerPC chips running at 1 *gigahertz*—that's 1,000 megahertz—thanks to an IBM innovation that uses copper instead of aluminum to make computer chips.

Faster Than a Speeding Bullet

Even assuming that what the pundits claim about new Intel chips is true, the 1GHz PowerPC should still be here sooner, run faster, and cost less.

The first new chips probably won't break the gigahertz barrier—expect to see them late this year, running at about 500MHz. But once the copper-chip process is up and running, it will be possible for PowerPC-based Macs to make even multiprocessing Windows NT boxes seem sluggish.

Of course, as these selfsame multi-processor NT workstations are currently proving, speed is fairly meaningless if most users can't afford it. That's why the 750's unique combination of high speed and low cost is so critical and why, as the PowerPC zooms into the Gigahertz Zone, it will be critical that the chips be affordable and flexible.

Think about it: the 750 is the only high-performance chip that appears in low-end as well as high-end computers and portables as well as towers. This must continue to be the hallmark of the PowerPC, with the G3 and beyond. Intel will *always* have something faster in the Not-Too-Distant Future. The PowerPC's goal

thing beyond the obvious speed boosts to current hertz-hungry applications.

First, Windows emulation should be built into the operating system. If new processors end up being more than twice as fast as Intel chips, then it should be possible to offer no-compromise Windows emulation on the Mac. (As you can see from our story "Can the Mac Really Do Windows?" elsewhere in this issue, effective Windows emulation doesn't exist just yet.) Imagine the irony if, in 1999, the best computer to run Windows applications turns out to be . . . a Macintosh. Talk about thinking different!

The next-generation Mac should also offer a significant improvement in its interface. While hardware has advanced tremendously in just the last few years, the interface that runs on those machines hasn't made any quantum leaps in over a decade.

Now it's time to take advantage of that processing power to effect real change. For example, Apple could assume that every Mac has an Internet connection and follow the interface implications from there. And voice recognition should become an integral part of the operation of the computer. IBM has amazing voice-recognition technology in its labs that's just waiting for a desktop computer fast enough, and an operating-system developer clever enough, to make voice a truly powerful way to work with a computer.

Before you scoff at this idea, remember that there once was a time when people thought that controlling your computer with an upside-down trackball was pretty dumb. But 200 million mouse users can't be wrong. ■

I'm sorry, Dave. I can't do that. However, I can forward your comments on this column to visionthing@macworld.com.

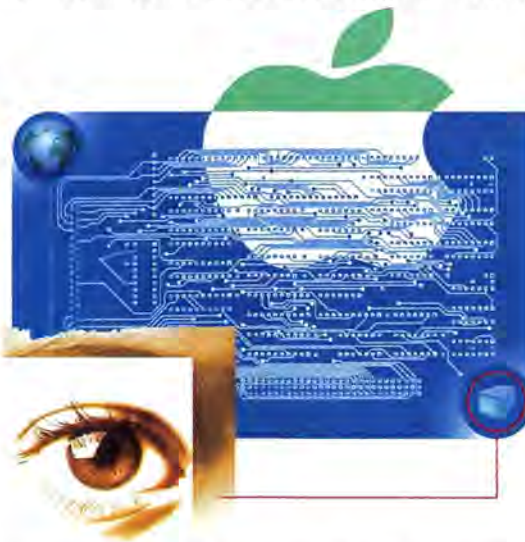

must be to keep performance affordable and accessible. Think of it as Performance for the Rest of Us.

More Powerful Than a Locomotive

Just as speed is meaningless if you can't afford it, it's also worthless if there aren't good uses for it. Running Microsoft Word ten times faster might be nice, but it's hardly a compelling use of 1GHz of processing punch. When the first Macs featuring next-generation PowerPC chips arrive, they'll need to offer users some-

WE'VE GOT 10 YEARS 24 HOURS BEH



Featured with additional paper trays

Elite XL 616

- 600 x 600 dpi resolution
- 16 pages per minute
- 1 year Platinum Exchange Warranty*
- Maximum print area: 11.69" x 20"
- Ledger, letter, legal, A4, envelope
- 250 sheet Universal Tray
- PostScript® Level 2 compatible, PCL 5
- 80 PostScript fonts, 15 PCL fonts
- 8MB RAM expandable to 64MB

Connectivity:

- Ethernet® (10 BaseT, 10 Base2)
- EtherTalk® TCP/IP
- Parallel, LocalTalk® RS422 Serial

Extra Universal Tray Add \$129

Second Paper Feeder** Add \$319
(Includes 250 sheet Universal Tray)

Second Paper Feeder** Add \$419
(Includes 500 sheet Letter Tray)

Extra 8MB memory*** Add \$89

Platinum Exchange Warranty Program

Additional year Add \$219

Two additional years Add \$330

Three additional years Add \$468

\$2199

Business Lease: \$79 month/36 month lease

BACKED BY GCC'S EXCLUSIVE PLATINUM EXCHANGE™ PROGRAM

HIND OUR TECHNOLOGY. D OUR SERVICE.

GCC Technologies® has spent the last 10 years refining printer technology for high-performance graphic arts printers. Now, GCC applies all of that knowledge and experience to our new line of business printers. A line of business printers that gives you the quality, reliability, and value your business demands. Whether you need camera-ready 1200 dpi resolution or large-format (11" x 17") output, or just about anything in between, there's a GCC Elite that's right for you and your business.

We have so much faith in the performance and reliability of our GCC printers that each one comes with our exclusive Platinum Exchange Program*. If our technical support people cannot walk you through a fix over the telephone, we'll ship you a replacement GCC printer by the next business day. That's right, the next business day!

Purchase a new GCC business printer with Platinum Exchange and see for yourself what 10 years of printer experience can do for your business.

Elite XL 608 LC

- 600 x 600 dpi resolution
- 8 pages per minute
- 1 year Platinum Exchange Warranty*
- Maximum print area: 11" x 17"
- Ledger, letter, legal, A4, envelope
- 250 sheet Universal Tray
- PostScript Level 2 compatible, PCL 5
- 80 PostScript fonts, 15 PCL fonts
- 8MB RAM expandable to 64MB

Connectivity:

- Ethernet (10 BaseT, 10 Base2)
- EtherTalk, TCP/IP
- Parallel, LocalTalk, RS422 Serial

Extra Universal Tray	Add \$129
Second Paper Feeder** (Includes 250 sheet Universal Tray)	Add \$319
Second Paper Feeder** (Includes 500 sheet Letter Tray)	Add \$419
Extra 8MB memory***	Add \$89

Platinum Exchange Warranty Program

Additional year	Add \$179
Two additional years	Add \$270
Three additional years	Add \$383

\$1799

Business Lease: \$65 month/36 month lease

Elite 1212

- 1200 x 1200 dpi resolution
- 12 pages per minute
- 1 year Platinum Exchange Warranty*
- Maximum print area: 8.5" x 14"
- Letter, legal, A4, envelope
- 250 sheet Universal Tray
- PostScript Level 2 compatible, PCL 5
- 80 PostScript fonts, 15 PCL fonts
- 8MB RAM expandable to 64MB

Connectivity:

- Ethernet (10 BaseT, 10 Base2)
- EtherTalk, TCP/IP
- Parallel, LocalTalk, RS422 Serial

Extra Universal Tray	Add \$129
Second Paper Feeder** (Includes 250 sheet Universal Tray)	Add \$399
Envelope Cassette	Add \$129
Extra 8MB memory***	Add \$89

Platinum Exchange Warranty Program

Additional year	Add \$139
Two additional years	Add \$210
Three additional years	Add \$298

\$1399

Business Lease: \$50 month/36 month lease

Service. Satisfaction. Guaranteed.

▶ Platinum Exchange.

Every GCC printer purchased direct is backed by our exclusive Platinum Exchange Program. If anytime during the warranty period a printer problem can't be resolved through GCC Technical Support, we'll send you a replacement printer† by the next business day. No downtime while waiting for repairs.

▶ 30-day money back guarantee.

Every printer and toner cartridge is fully backed by our unconditional, no-questions asked, 30-day money back guarantee.

▶ One full-year warranty.

Every GCC printer is protected by a minimum one year parts and labor warranty. Yearly extensions are available.

▶ FREE unlimited technical support throughout the warranty period.

GCC Technologies is on call for you at 781-276-8620, Monday through Friday, 9 AM to 8 PM (et); Saturday, 10 AM to 4 PM (et) or by EMail: support@gcctech.com.

† Shipping and handling will be reimbursed only if product is defective.



To order, Toll Free

1-800-422-7777

Mon-Fri 9 AM to 8 PM (Eastern Standard Time)
Sat 10 AM to 4 PM (Eastern Standard Time)

www.gcctech.com

Circle 43 on reader service card

Keycode 804MWC

*Platinum Exchange included for one year. Extended options available. Some restrictions may apply. Call for details.

**The Elite XL 608 LC supports one optional paper feeder. The Elite XL 616 supports two additional paper feeders.

***Please call for pricing on additional memory configurations.

News

multimedia

Apple Delivers QuickTime 3.0

BUT KEY AUTHORING
APPLICATIONS AWAIT
UPGRADES

by Stephen Beale

QuickTime 3.0, the latest version of Apple's multimedia system software, is finally here—with a fast new video compressor and a long list of other enhancements. But don't expect to see QuickTime 3.0 movies dancing across your screen anytime soon. To create QuickTime 3.0 movies, you'll need QuickTime 3.0-enabled production tools, and so far only a handful of authoring packages support the new software.

QuickTime, one of Apple's few unabashed success stories of recent years, provides software developers with a rich set of resources for producing and playing back multimedia content. Its most visible component is the QuickTime movie, which can play synchronized tracks of video, audio, and text. But QuickTime also offers a wide range of system-level multimedia functions, including the ability

to import and export more than 50 media types. This makes it much easier for developers to add new video, audio, and animation features to CD-ROM titles and multimedia-production tools (see "What's New in QuickTime 3.0," in this section).

Apple first announced QuickTime 3.0 about a year ago, offering sneak previews of

a new video-effects architecture that lets you apply Adobe Photoshop-style filters in real time to moving images. The company posted a beta version of QuickTime 3.0 on December 1, 1997; the final release was scheduled to hit Apple's Web site (www.apple.com/quicktime/) in early February.

There is no charge to download the software, which

includes a new version of the browser plug-in for viewing QuickTime movies on the World Wide Web.

Early Applications Dozens of hardware and software vendors have announced that they plan to support QuickTime 3.0 in future products. But so far, only a few authoring programs offer access to QuickTime's new features.



To get the ball rolling, Apple announced HyperCard 2.4, a \$99 update to its authoring software, which can open any QuickTime 3.0-readable file, including QuickTime VR panoramas.

HyperCard's scripting language lets you use a Find command to navigate to any portion of a QuickTime movie text track. You can also use scripting commands to scale, flip, mirror, rotate, and skew QuickTime movies.

At Macworld Expo in San Francisco, Apple's chief QuickTime architect, Peter Hoddie, demonstrated a \$30 program called QuickTime Pro that lets you drag and drop one QuickTime movie into another. However, Apple has not offered further details on the software, such as what other features it may offer or when it will ship.

Among other developers, Scitex Digital Video (415/369-5111, www.scitexdv.com) announced support for QuickTime 3.0 in Microsphere, its \$2,000 digital-video-editing package. Script Software (916/546-9005, www.scriptsoftware.com) has released iView, a free QuickTime 3.0-based media-cataloging program that can be downloaded from the company's Web site.

Macromedia (415/252-2000, www.macromedia.com) has developed a QuickTime 3.0 Asset Xtra for Director and Authorware that lets you crop, mask, rotate, and scale imported QuickTime movies. The \$200 plug-in should be available by the time you read this. Macromedia says that Final Cut, its forthcoming digital-video-editing software, will offer full support for QuickTime 3.0.

Adobe Systems (408/536-6000, www.adobe.com) has offered few specifics on its plans for QuickTime 3.0. However, *MacWeek*, citing

continues on page 28

industry

Apple Dismantles Claris

FILEMAKER, HOME PAGE

GO TO NEW COMPANY

by Stephen Beale

Apple's revitalization efforts took an unexpected turn January 27, when the company announced that Claris, its ten-year-old software subsidiary, will be rechristened FileMaker, Inc., and will focus exclusively on the FileMaker Pro database and Home Page Web authoring tool. Apple—at least for now—will assume responsibility for other Claris products, including ClarisWorks, Emailer, Impact, and Draw, as well as Mac OS 8, HyperCard, and other Apple-branded software that was distributed by Claris. Some 300 Claris employees, including an unspecified number involved in software development, will lose their jobs. Apple declined to say how many employees would remain.

FileMaker Rocks Apple says that FileMaker Pro, the best-selling database software for the Macintosh, is also the second-leading file manager for Microsoft Windows, which now accounts for about half of the product's sales. The restructuring theoretically frees the subsidiary to pursue the Windows market as Apple focuses on the Mac OS. Home Page remains in the FileMaker fold due to the program's tight integration with the database software. FileMaker Pro 4, released last year, includes features that make it easier to put databases on the Web.

Claris president Domi-

nique Goupil, who retains the top spot in FileMaker, Inc., says the subsidiary has other database and Web publishing products in development. Forthcoming products will build on FileMaker Pro's reputation as an easy-to-use database.

Murky Future Prospects are murkier for the Claris-branded products that have returned to Apple's fold. Apple executives say that ClarisWorks remains a strategic asset for the company; Apple bundles the integrated productivity software with its Mac systems and claims that it is the best-selling productivity package in the education market. However, ClarisWorks for Windows could be in trouble; Apple says the Mac version will get the lion's share of attention.

Apple would not comment on plans for the other Claris packages, but Emailer in particular appears to be living on borrowed time. Jud Spencer, the only programmer credited on the e-mail client, has moved to Microsoft and is working on the Mac version of Outlook Express, the e-mail software bundled with Internet Explorer.

Missing Details Apple executives were cagey when discussing the 300 layoffs associated with the Claris restructuring. Claiming that the Claris and Apple workforces are intertwined, Apple would not reveal Claris's total employment, making it difficult to assess the move's overall impact on the subsidiary's bottom line. However, analysts who follow Apple say the layoffs represent 30 to 40 percent of Claris employees.

Apple says the layoffs were "across the board," affecting personnel involved in software development in addition to sales and marketing. The com-

pany would not reveal how many programmers were let go, but the magnitude of the layoffs strongly suggests that Apple plans to curtail development on at least some of the Claris-branded products.

storage

The Year of Mac DVD?

AS DVD HEATS UP, E4 BRINGS THE FIRST DRIVES TO THE MACINTOSH

by Jeff Milstead

DVD, the high-capacity successor to the compact disc, is suddenly hot. Consumer DVD players are filling electronics stores, and more than 300 DVD movie titles are now available. They're fast becoming standard equipment on PCs. And now Apple has added support for DVD's Universal Disk Format in Mac OS 8.1.

There's just one small problem: the currently available DVD drives use the IDE interface found in PCs and



E4's CoolDVD is the first DVD drive for the Macintosh.

Apple's latest Macs; they do not support the SCSI connections in older Mac models. As a result, drives for PCs have been available for more than a year, while Mac users have been forced to wait. However,

continues

the wait for the latest DVD wrinkle—rewritable DVD-RAM—may be over soon with drives hitting catalogs this March. Hitachi is leading the pack with its first DVD-RAM drive, but you can expect to see rewritable drives from Toshiba and Panasonic as well.

E4 Debuts The first Macs with built-in DVD drives are scheduled to appear by mid-1998; Apple originally had planned to offer DVD by the end of last year. For now, your only choice is CoolDVD, a \$499 Mac DVD upgrade kit from E4 (408/441-6060, www.e4.com).

CoolDVD consists of an internal IDE-based DVD drive, software, and a single-slot PCI card, which is used to decode the DVD MPEG 2 video stream; the card also accepts audio input from the drive. The drive works with the Power Mac 4400, the new G3 desktops, and other Macs with IDE connectors; E4 plans to offer a SCSI version of CoolDVD by March. A second optional board provides outputs for S-Video, RCA analog audio, and SPDIF digital audio.

A New Generation E4 is using what's known as a second-generation DVD drive. The first generation of drives could read CD-ROMs, but not CD-R discs, including Photo-CD media. Current DVD drives support CD-R. And future DVD-RAM drives will be backward-compatible with all CD-ROMs.

The E4 package includes DVD player software that uses an interface similar to that found in the Apple CD Audio Player. You can control DVD movies as if you were using a stand-alone DVD player.

You also have access to unique, title-specific DVD features, such as parental restriction and the ability to choose different camera angles or alternative language tracks.

graphics

Merger Wave Hits Plug-in Publishers

RECENT MARKET TRENDS
FAVOR LARGER VENDORS

by Stephen Beale

Changes are afoot among vendors of graphics extensions—Adobe Photoshop plug-ins, QuarkXTensions, and other products that add new functions to popular design programs.

On January 6, Extensis (503/274-2020, www.extensis.com) announced that it had acquired Astrobyte, publisher of the BeyondPress QuarkXTension, for creating Web pages from QuarkXPress documents. Two weeks later, the World Wide Power Company (303/940-0600, www.thepowerco.com) announced that its owner, Cyndie Shaffstall, along with Jim Jensen, president of GeneSys, had purchased XChange, a major distributor of QuarkXTensions that also publishes *X-Rzy* magazine, for QuarkXPress users. The World Wide Power Company (WWPC) distributes plug-ins, QuarkXTensions, and other graphics products; GeneSys is a developer of database-publishing tools for the Web.

The timing of the acquisitions may be coincidental, but both point to the special challenges facing developers of graphics extensions—and could have implications for the availability of innovative new extensions in the future.

Limited Resources Photoshop plug-ins and other extensions have been a boon for con-

tent creators, because they offer a low-cost means of enhancing and customizing key design applications. Most plug-ins have come from small software developers—even solo programmers—that may have innovative product ideas but limited marketing and distribution resources.

To compensate, many have turned to outfits, such as XChange and the WWPC, that provide a central source for graphics utilities. XChange, founded in 1989, focused exclusively on QuarkXTensions and other Quark-related products. However, the company hit financial difficulties about two years ago and was heavily in debt at the time of the WWPC acquisition, Shaffstall says.

One QuarkXTensions developer, Jacques Viker, of Vision's Edge (904/386-4573,

black—about nine months from now, she hopes—she plans to merge its operations into her own, with a single set of offices in suburban Denver. Shaffstall is also seeking a publisher for *X-Rzy*.

A Different Approach Extensis chose a different path to fortune. Beginning in 1994 with a single set of Adobe PageMaker add-ons—PageTools—Extensis used acquisitions, distribution deals, and its own software development resources to build a product line that now includes QX-Tools, QX-Effects, PhotoTools, VectorTools, Intellihance, Portfolio, PreFlight Pro, PreFlight Designer, MaskPro, BeyondPress, and its latest release, PhotoFrames. This gives Extensis an advantage over smaller extensions developers, since it can divide marketing costs and other overhead among a larger number of products.

In addition to bringing BeyondPress into the fold, the Astrobyte deal gives Extensis extra programming expertise in QuarkXTensions and Web publishing. You can thus expect to see more of both from Extensis, although the company has not yet announced any new products arising from the Astrobyte acquisition.

Back in the Fold Meanwhile, MetaCreations (805/566-6200, www.metacreations.com), which last year said that it was getting out of the Photoshop-plug-in business, has had a change of heart.

Later this year, the company plans to release an upgrade to Kai's Power Tools, the package that launched the boom in Photoshop plug-ins. However, chief interface officer Frank Casanova says the company has not yet decided whether to release the upgrade as a plug-in, a stand-alone application, or both. Nor has Meta-

continues



www.xtender.com), says that XChange fell behind in payments to some developers and failed to pay others at all. While XChange accounted for just 25 percent of his company's business, he says, other, smaller developers were almost completely dependent on XChange for their revenue.

Shaffstall says she plans to spend the next six months paying off XChange's creditors. Once XChange is back in the

Hasta La Vista, Norton™

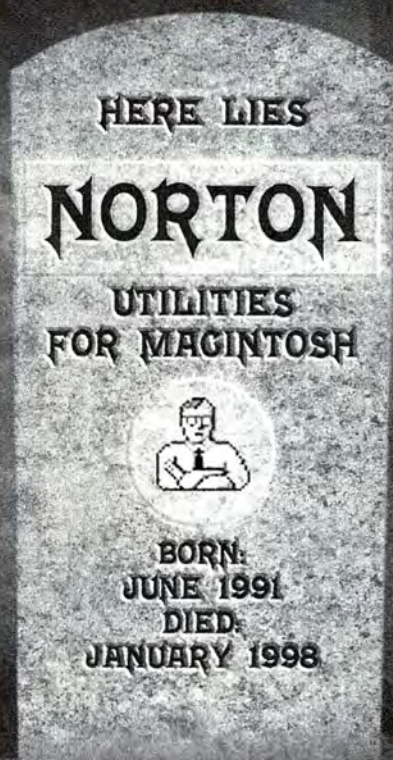

For many years, Norton Utilities for Macintosh was the premiere utility for correcting drive problems. Until now.

TechTool Pro 2 is now the best troubleshooting utility available for Macintosh. Why? We've recreated all of the best features of NUM and combined them with TechTool's large arsenal of diagnostic tests. This means that not only can you find and correct drive and file problems (like Norton does), but you can also test all those other critical parts of your system that Norton ignores like RAM, CPU, Floppy drives, CD-ROM drives and much, much more. In fact, no other utility on the market can check the fitness of your Macintosh to the extent of TechTool Pro.

Just because TechTool Pro is the most advanced diagnostic utility available doesn't mean it's difficult to use. In fact, with version 2, we've added an easy-to-use interface that makes checking your Macintosh a snap. For the advanced user, our Expert mode allows you to control and configure TechTool Pro in almost any way you wish.

For more information about TechTool Pro 2, call us at the number below or visit our web site. You'll see that anything else is just a box full of bones.



For More Information:
Toll Free: 800-829-6227
International: 707-837-8012
FAX: 707-837-0209
info@micromat.com
www.micromat.com

 **MICROMAT**
COMPUTER SYSTEMS
8868 Lakewood Drive
Windsor, CA 95492



800-213-6359
Source Code #MCM8
Order #87067

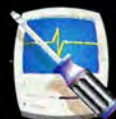

TechTool Pro®

Creations determined the fate of KPT Convolver, an image-enhancement plug-in introduced in 1995. MetaCreations also offers plug-ins for Adobe After Effects and Adobe Illustrator/Macromedia FreeHand.

Implications Extensis's acquisition of Astrobyte follows a general trend toward consolidation among graphics-software vendors. The big fear among users is that this will lead to fewer innovative products. However, Astrobyte founder Ralph Risch says the acquisition will spur innovation, by allowing him to focus on product development rather than marketing and other considerations.

Jeff Butterworth, founder of Alien Skin Software (919/832-4124, www.alienskin.com), acknowledges that a relatively large vendor such as Extensis—whose PhotoTools competes with Alien Skin's Eye Candy—has marketing and distribution resources he can't match. Nevertheless, he believes there will always be a place for companies like his. "Bigger guys will keep swallowing smaller guys, but small guys will keep coming along," he says.

Shaffstall says she doubts that the Extensis/Astrobyte deal indicates a larger trend toward consolidation among

plug-in vendors. If anything, she says, the popularity of extensions has bigger implications for Adobe and Quark. Because plug-ins make it so easy to customize your software, she says, many users are hesitating before they upgrade Photoshop or QuarkXPress. As a result, she expects to see fewer revisions of major graphics packages.

multimedia

FireWire Heats Up Digital Video

NEW PRODUCTS USE
HIGH-SPEED INTERFACE

by Brooke Wheeler

FireWire, the high-speed digital-bus interface also known as IEEE 1394, is igniting a new generation of authoring tools for digital-video producers. While Apple has been slow to incorporate FireWire into its motherboards—that's slated to happen by the end of the year—developers are rushing to market with digital-video systems that take

advantage of FireWire's blazing 400MBps transfer rates.

Adaptec Connects FireWire-based video-editing systems typically include a PCI card, FireWire cable, and QuickTime authoring software. Three vendors, ProMax (714/727-3977, www.promax.com), Pinnacle Systems (650/526-1600, www.pinnaclesys.com), and DPS (606/371-5533, www.dps.com), have unveiled systems based on Adaptec's new HotConnect Ultra 8945, which features three FireWire connectors and an Ultra Wide SCSI accelerator on a single board.

The \$695 FireMax-2, from ProMax, slated to ship in February, includes Adaptec software drivers and plug-ins for Adobe Premiere and After Effects. ProMax has also dropped the price of its original FireMax—based on Adaptec's single-port AHA-8940 PCI card—from \$595 to \$495.

Pinnacle Systems' \$799 miroVideo DV300 FireWire digital-video capture board includes Adobe Premiere LE for video editing and DVTools software for controlling digital camcorders. The forthcoming DPS Spark video-editing system, priced at \$999, will include a full version of

Adobe Premiere in addition to the new Adaptec card. German developer Octopus Systems (49-40-270965-0, www.octopus.de) is shipping the \$3,500 DV Studio 1394,



which includes a FireWire PCI card, external connector box, and Adobe Premiere.

Radius Deals At Macworld Expo in January, Radius (408/541-6100, www.radius.com)—one of the first companies to offer FireWire-based digital-video tools—announced a deal with Media 100 (508/460-1600, www.media100.com) under which the latter will incorporate Radius technology into its video-editing systems. Media 100 will acquire distribution rights to EditDV, Radius's \$999 video-capture system, along with the PhotoDV FireWire card and MotoDV video-capture software.

DV Cameras As FireWire-based video-editing products hit the market, other vendors are keeping pace with DV camcorders that include FireWire interfaces.

Panasonic (201/348-7000, www.panasonic.com) is shipping the \$2,000 PV-DV700 and \$2,500 PV-DV710 DV cassette camcorders. Canon (516/488-6700, www.canondv.com) is shipping the \$4,500 Canon XL1, the professional big brother to the \$2,500 Optura mini DV camcorder. In February, Sony Electronics (408/432-0190, www.sony.com) plans to ship its lightweight \$1,000 DFV-V300 video camera.

New Kodak Digital Camera Uses FireWire

FIREWIRE MAY BE A BOON FOR DIGITAL VIDEO, but it can also provide a speedy gateway for high-resolution still images. Eastman Kodak (716/724-1568, www.kodak.com) has built a FireWire interface into its new DCS 520, a \$15,000 digital single-lens reflex camera based on the Canon EOS.

Targeted at photojournalists, the camera captures 36-bit color images at 1,736-by-1,160-pixel resolution, producing a 6MB file. With files that big, a serial connection would be too slow, says Kodak product manager Gerard Magee.

Magee admits that Kodak is a bit premature in offering FireWire. When development began on the

new camera, the company expected that Apple would have its first Macs with built-in FireWire connections by the end of 1997; Apple currently plans to offer FireWire Macs by the end of 1998. Magee expects that many DCS 520 resellers will bundle the camera with FireWire interface boards.

In addition to the FireWire interface, the camera includes dual PC Card slots for removable storage and image transfer. It also features a burst rate of 3.5 frames per second, an ISO range of 200 to 1600, and a color LCD that shows a histogram of each captured image. Kodak expects to ship it in March.—MACWORLD STAFF

These machines

keep up

with your creativity.



The SuperMac S900 line provides reliable and expandable architecture, so you always have the best creative tools at hand.

**Now with
Mac OS 8**

You've got great ideas, and you deserve a machine to match. The SuperMac S900 family offers a range of models that combine superior engineering and performance with convenient upgradeability—all for a very competitive price. Plus the S900 architecture makes it easy to upgrade to a faster processor or even a dual processor. You can also add many PCI cards, internal SCSI drives, and lots of memory. So there's no need to worry about your machine becoming obsolete. All this from UMAX, a company dedicated to the Mac OS system and rated #1 in both service and purchase satisfaction in a June 1997 *Macworld* poll. The SuperMac S900 from UMAX. Finally, there's a machine that can meet your creative demands.

S900 SPECIFICATIONS:

MODEL NAME	S900BASE	S900i/250
Processor Type	604/150MHz (Upgrade now to PowerPC 750*)	604e/250MHz
Interleaved RAM	64MB up to 1GB	64MB up to 1GB
CD-ROM Speed	24X SCSI	24X SCSI
Hard Drive	4GB SCSI	4GB ULTRA SCSI
Drive Bays	7 total/4 open	7 total/3 open
Total PCI Slots	6	6
Ethernet	10Base-T	10/100Base-T
Ultra-Wide SCSI Card	Optional	Yes
Zip Drive	Optional	Yes
Video Memory	4MB 1X Micro	4MB 1X Micro

*Special S900base limited time offer: \$1395 for a 250MHz 750 Processor upgrade with 1MB backside cache—see web for details.
Monitor not included. Estimated street price for S900base is \$2695, and for S900i/250 \$3695. Price and features subject to change without notice.



For more information on where to purchase the S900, call
1-888-625-UMAX or visit us at <http://www.umaxcc.com>

UMAX
Computer Corporation



© 1998 All rights reserved. SuperMac is a registered trademark licensed to UMAX Computer Corporation. Mac and the Mac OS logo are trademarks of Apple Computer, Inc. used under license. PowerPC and the PowerPC logo are registered trademarks of International Business Machines Corporation.

Circle 99 on reader service card

"APPLE DELIVERS QUICKTIME 3.0"

continued from page 23

anonymous sources, has reported that Adobe plans a May 1998 release for Premiere 5.0, a new version of the company's digital-video-editing software. It's a safe bet that the

upgrade will support QuickTime 3.0.

The Vector Shuffle One new feature in QuickTime 3.0 is a vector-animation track; vector animations typically consume much less file space than equivalent bitmapped animations and are thus ideal for use on the Web. Lari Software (919/968-

0701, www.larisoftware.com) offers a \$99 program called LightningDraw/Web for creating QuickTime 3.0 vector animations. By spring, the company plans to release a more comprehensive package, Electrifier Pro, that produces bitmapped and vector animations in a variety of formats.

PaceWorks (415/261-6180, www.paceworks.com) says it will support the QuickTime 3.0 vector track in a future version of its ObjectDancer animation software. But Macromedia says that Flash, its vector-animation program, will not write to QuickTime's vector format unless users demand the capability. Until recently, you needed the Shockwave Flash browser plug-in to view Flash animations; Flash animations in the QuickTime vector format would be viewable by anyone with the QuickTime plug-in. However, a new Xtra from Macromedia lets you export Flash animations as Java applets that can be viewed on any Java-capable browser.

Deployment Far and Wide One of QuickTime's strengths is its transparent support for a wide variety of digital media types. This makes it a good vehicle for delivering content over the Internet; with the latest version, you can stream audio and video without requiring users to keep a closetful of browser plug-ins. But for QuickTime 3.0 to succeed as an Internet technology, a critical mass of users—including those on the PC side—must install the software.

Apple expects that many Macintosh users will download the upgrade from the Web; QuickTime product manager Mitchell Weinstock estimates that as of January, 1 million users per month were downloading QuickTime 2.5. But given QuickTime's file size of 5MB to 6MB, many will no doubt balk at such a bandwidth-chewing download. So Apple is also counting on CD-ROM-title developers to pollinate desktops with the upgrade. Weinstock figures that every PC sold these days includes at least one title created with QuickTime; install the title and you also get the Apple software.

What's New in QuickTime 3.0

NEW FEATURES IN QUICKTIME TRANSLATE into new capabilities for multimedia and digital-video-production tools. Here's some of what you can expect to see in authoring programs that support QuickTime 3.0:

A Better Codec With QuickTime 3.0, Apple has licensed compression/decompression (codec) technology from Sorenson Vision; Sorenson Video is now QuickTime's default codec. It's faster and offers better video quality than Cinepak, the default codec in previous versions of QuickTime. However, if movies are compressed with Sorenson Video, you'll need to install QuickTime 3.0 to view them. Cinepak remains in QuickTime 3.0 for backward compatibility, and the Apple software supports other codecs as well.

Audio Connections Apple has signed a series of technology-licensing deals that extend QuickTime's audio capabilities: voice-compression software from Qualcomm, a music codec from QDesign, and a pair of MIDI applications from Roland. Roland's Sound Canvas provides QuickTime with 128 built-in MIDI instruments; GS Format software adds support for Roland's GS technology, an enhancement to the basic MIDI specification.

Down the Stream Seeking to improve QuickTime's appeal as an Internet standard, Apple has added streaming-audio and -video capabilities, which allow a movie to begin playing as it is being downloaded. You can also tie multiple-resolution versions of a QuickTime movie to a single link, sending the version most appropriate for the browser's data rate. Unlike with other streaming-media technologies, such as RealNetworks' RealAudio, you don't need special server software; you put the QuickTime movie on your Web site, and the movie automatically streams when downloaded.

Early demonstrations with QuickTime's new video and audio codecs indicate excellent sound and image quality. However, if you want to pro-

duce a live Webcast in which the audio and/or video streams in real time, you'll need one of the competing server-based streaming technologies.

Vector Animation A new vector-animation track lets you create animated logos, text treatments, and other effects in small file sizes ideal for use on the Web. Lari Software supports QuickTime 3.0 vector animation in LightningDraw Web; PaceWorks says it will support the format in a future version of ObjectDancer.

New Formats QuickTime 3.0 adds several new media types to an already long list of sup-



ported formats. These include the DVCAM format for digital-video cameras, which allows QuickTime applications to work directly with DVCAM video streams.

Previous versions of QuickTime supported two flavors of Motion JPEG; QuickTime 3.0 adds support for OpenDML M-JPEG and Avid Video Resolution M-JPEG.

Video Effects A new video-effects architecture allows developers to create filters that can be applied in real time to QuickTime movies. For example, you can add an emboss effect to give the illusion that video frames are etched in stone.

Cross-Platform Parity QuickTime 3.0 is the first fully cross-platform version of QuickTime. Previously, QuickTime for Windows was limited to movie playback; now you can also create QuickTime content under Windows.

Out of Your Mind!

NEW
2D Performance
NOW **50%
FASTER**

Featuring Nexus GA from ATI

From your brain to the big screen and the printed page faster than you can change your mind - ATI's Nexus GA will dramatically improve the graphics capabilities of your Macintosh computer. Specifically designed for graphics professionals and content creators, ATI Nexus GA offers high-performance 2D and 3D graphics in one affordable, easy-to-install PCI accelerator board.

Nexus GA offers 8MB or 16MB of WRAM memory, for incredible 2D graphic performance with true color in all the modes you demand up to 1920x1080. Work better and faster in all your favorite applications like Photoshop, and Infini-D

2D Performance Comparison - MacBench '98

ATI NEXUS GA	546
IXMICRO Twin Turbo 128MB	309
Matrox Millennium	298

Plus, with Nexus GA's 3D functionality and QuickDraw3D™ support you can add 3D elements to any of your design and multimedia projects. Nexus GA will take your content creation to new heights with a full suite of 3D effects and workstation-class performance.

Because Nexus GA is from ATI, makers of award-winning graphics accelerators for Macintosh computers, you can rest easy that Nexus GA will work seamlessly with your applications. Nexus GA the fastest, ultra-high resolution, true color performance - to choose anything else, you'd have to be out of your mind.

© Copyright ATI Technologies Inc. 1998. ATI, 3D RAGE PRO, and NEXUS are trademarks, or registered trademarks of ATI Technologies Inc. All other company and/or product names are trademarks and/or registered trademarks of their respective manufacturers.

MacBench 4.0 HiRes Publishing Mixes Tested on PowerMac G3/233MHz/32MB RAM. All boards have 8MB. Test mode: 1152 x 870 x 75Hz @ 32bpp. Tested using Driver Versions: Nexus 1.1 / IXMICRO Twin Turbo 4.0.2 / Matrox Millennium 2.10.

Features and specifications are subject to change without notice.



MICRO CENTER

Mac

1-800-852-8888

Circle 256 on reader service card



Now You See It.™

www.atitech.com/macwo



Reviews

Personal Image Editors

BEGINNERS WITH AGING

HARDWARE NEEDN'T APPLY

IF YOU'RE LIKE MOST FOLKS, YOU take your snapshots to the cheapest lab you can find and rely on the photographic equivalent of a fry cook to churn out your precious memories as fast as you can say, "Shouldn't the sky be blue?" Fast photos have their place, but wouldn't it be great if you could be in control of your own digital darkroom? You could select the best shots, balance the colors, sharpen the details, and crop away the extraneous background stuff that you didn't mean to photograph in the first place. No more apologizing about the one where your finger got in the way—every photo would be picture-perfect.

For the uninitiated, the thought of operating a digital darkroom may be a bit intimidating. Armed with the proper software, however, a reasonably intelligent person should be able to figure it out. That's where the latest round of personal image editors comes into play. MetaCreations' Art Dabbler 2.1.1, The LivePix Company's LivePix 1.1, and Adobe's PhotoDeluxe 2.0 are all designed to help the burgeoning electronic shutterbug correct and experiment with pixel-based photos. Any of the three can be yours for \$49, and both LivePix and PhotoDeluxe are bundled with many brands of digital cameras. Also encouraging, each of the companies produces a professional-level editing tool—Painter, Live Picture (a product of LivePix's parent company),



and Photoshop, respectively. But that's where the similarities end; the three products take very different approaches, with varying degrees of success.

Dabbler Makes New Demands

Art Dabbler is more an image *enhancer* than an image editor. Like Painter, it offers a host of natural-media tools and paper textures for embellishing your photographs. If you get particularly ambitious, you can integrate a string of photos into a simple flip-book animation. But the feature of most interest to digital-camera buffs is cloning: Art Dabbler lets you take

any tool and use it to paint an image onto a blank canvas. With only a modicum of drawing experience, you can convert a photograph into a pencil sketch, a charcoal drawing, or an impressionistic painting. It's a lot of fun, and the results can be downright charming.

I do have two complaints about Art Dabbler. First, its outrageous hardware requirements exclude many of the artistic novices it's meant to appeal to. While its predecessor, Dabbler 2.0, cost \$20 more, it ran speedily on a 68030 Mac and required just 4MB of application RAM; Art Dabbler requires a Power Mac and a

REAL PRODUCTS
REAL RATINGS

Reviews you can trust: Macworld rates only final shipping products, not prototypes. What we review is what you can actually buy.

OUTSTANDING: ★★★★★

VERY GOOD: ★★★★

GOOD: ★★★

FLAWED: ★★

UNACCEPTABLE: ★

staggering 12MB of application RAM. This might be OK if your more-powerful hardware bought you access to more-powerful features, but it doesn't—Art Dabblor 2.1.1 is functionally identical to Dabblor 2.0. The CD comes with some extras, including plug-ins from the Kai's Power Tools collection, but not so much as a single command in the core application has changed.

Second, Art Dabblor isn't much more than a subset of Painter. Its only unique features are the online guides adapted from the old Walter Foster drawing library. As a proud owner of the original *Animation* book by Preston Blair—the Disney artist who created the dancing hippos in the movie *Fantasia*—I'm partial to these online adaptations (see “Back to Basics”).

However, I would have welcomed a few more features catering specifically to beginning artists.

None of which is to say that Art Dabblor isn't worth \$49; even a subset of Painter's capabilities makes for a pretty nifty program. Still, I can't help but imagine what MetaCreations' clever programmers could have done with Art Dabblor if they had tried harder to remember how it felt when they learned to draw.

Night of the Living Pix

If Art Dabblor is more of a painting program than an image editor, LivePix is more of an illustration program. LivePix lets you merge and edit images inside an independent project file, ensuring that you never harm a pixel of the original images. Every image in the project is treated as a separate object, selections are defined as point-by-point paths, and a line of text remains editable from one session to the next. When it saves the finished composition as an image file, LivePix rasterizes the images at a new resolution.

In short, LivePix is a miniature version of Live Picture. But while this object-oriented approach makes sense for editing large images—say, more than 10MB—it actually slows down the process of editing 1MB digital-camera files. When you import an image into your project, LivePix generates an interpolated proxy so the image looks its best on screen. Any time you zoom in or out,

LivePix has to redraw each and every object to produce a smooth screen preview. If you select a portion of an image and then paste it into the project, LivePix treats the selection as an editable clipping path so you can mask or unmask portions

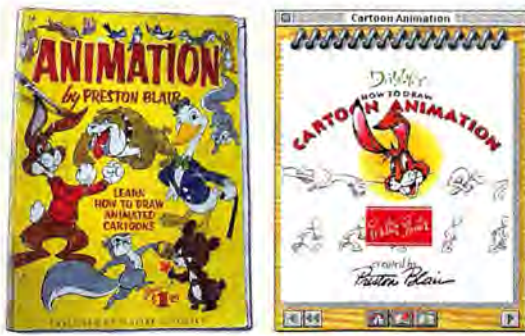

Back to Basics | I spent my formative years pawing Preston Blair's original *Animation* guide (circa second grade, left), so naturally I'm all for the electronic edition built into Art Dabblor (right). Otherwise, Art Dabblor is merely a subset of Painter's capabilities.

of the original image later. This makes for a lot of heavy-duty computations. On a PowerPC 750 machine, a typical composition with six or seven elements routinely takes 30 seconds or more to display on screen, compared with a second or two in a standard image editor.

If all of this strikes you as a bit complicated for a \$49 consumer application, you've anticipated my next complaint: Most professional artists have a hard time figuring out Live Picture, and LivePix in its own small way is every bit as obtuse. Here's a program that's bundled with such entry-level products as Panasonic's CoolShot camera and Epson's Stylus Photo printer, yet it requires a Power Mac and 20MB of application RAM. (For what it's worth, I encountered frequent low-memory errors until I raised the memory partition to 24MB.) LivePix suppresses the standard Macintosh scroll bars, requiring you to switch to a hand tool when you want to scroll. Meanwhile, you can't access the hand tool from the keyboard, an ease-of-use convention that dates back to MacPaint. Drag-and-drop support is limited to applications that support OLE 2.0, thus ruling out the Finder and just about every mainstream program without the word *Microsoft* in its title. Although LivePix is object-dependent, there's no way to examine the stacking order of objects in a palette—making the program *harder* to use than Live Picture in this respect.

Finally, LivePix has a known conflict with Mac OS 8.0: if the System-Wide Platinum Appearance option is active, LivePix crashes during start-up. The upshot is that while LivePix might seem a real bargain to a proficient artist—you can buy 80 copies of LivePix for what it cost to buy the original Live Picture—I had an easier time getting to first base with Photoshop. It's hard to imagine a product less suited to the needs of weekend image editors.

Shedding Light on the Darkroom

While PhotoDeluxe draws freely on Photoshop's capabilities—many of its filters are lifted directly from the image editor cum laude—PhotoDeluxe manages to go its own way in no uncertain terms. Although I don't altogether agree with its approach, PhotoDeluxe makes considerable efforts to meet the needs of first-time pixel polishers.

Like LivePix, PhotoDeluxe offers a gallery feature to help you organize your images. (With a gallery, you can pick and choose from hundreds of images displayed as thumbnails.) But unlike LivePix, PhotoDeluxe launches a separate program, Storm Technology's EasyPhoto, every time you access the gallery. The good news is that EasyPhoto is substantially more capable than LivePix's gallery feature. To add an entire folder of images to the gallery, you just drag the folder from the Finder and drop it into EasyPhoto; in LivePix, you must laboriously load an image at a time. The bad news is that the interaction between PhotoDeluxe and EasyPhoto is a bit clumsy. By default, EasyPhoto wants to save its galleries to one folder, and PhotoDeluxe insists on opening them from another. If you're a novice, this design quirk makes for considerable confusion.

When it comes time to edit images, PhotoDeluxe holds your hand and walks you through the process (see “Magical Pixel Tour”). Imagine a Microsoft-type wizard that doesn't treat the user like a mindless dweeb, and you have an idea of how PhotoDeluxe works.

Say you want to remove a telephone line that drops down into your otherwise gorgeous sunset picture. When you click on the Remove Elements button, PhotoDeluxe displays three index cards presenting three steps: select the offending phone wire, clone it away, and exit the *continues*

QuickMail Office 1.0.2

UPDATE PLUGS SECURITY HOLES

OUR RECENT REVIEW OF QUICK-Mail Office 1.0 (see *Reviews*, February 1998) reported two serious security problems, along with CE Software's promise to fix those problems in an upcoming release. After posting a temporary fix to its Web site to mitigate some of the security risk, CE in mid-January released version 1.0.2, with complete fixes for all known security problems. In addition to these fixes, the update adds several useful functional and performance enhancements.

A new set of TCP/IP security preferences resolves the security hole that let outsiders reprogram mail filters remotely via e-mail messages; you can list the specific IP addresses that can change filters remotely, preventing abuse by outsiders. A second security problem let junk-mail distributors use a QuickMail Office server as a relay station to pass junk mail to other networks. A new set of controls patches that hole by limiting mail relaying to a list of domain names and IP addresses you specify. In addition, this version improves the filters' overall security by sending alert messages when it detects attempts to breach security.

Functional enhancements include the ability to list subsets of users in list windows, locate users in a list by typing their first names, and initiate mail retrieval by using the Unix "finger" protocol. Performance improvements speed up mail processing significantly and increase the number of attempts the server makes when delivering mail to offline users.

Macworld's Buying Advice CE Software responded quickly and responsibly to our report of security problems, and our testing found version 1.0.2's fixes very effective at blocking server attacks by outsiders. This update makes QuickMail Office a first-rate Internet mail server.—MEL BECKMAN

Remove Elements mode. Not only are the steps as easy as pie, but the selection and cloning tools actually surpass their equivalents in Photoshop for sheer usability. And it's entirely up to you if you want

its hardware requirements, but even its minimum requirements of a 68040 with 16MB of RAM place it well outside the reach of many home users.

But enough ranting. If you have the hardware, Art Dabbler is a diverting tool for enhancing your digital scrapbook, and PhotoDeluxe is a fine introduction to the world of image editing. My only concern is that both programs have relatively low feature ceilings.

If you're the kind of person who catches on pretty quickly, you're likely to get frustrated with Art Dabbler and PhotoDeluxe after about a year. For \$49, a year of use is a pretty reasonable deal. But if I were just starting out, I would go with the \$149 Color It 3.2 from Micro-Frontier (see "Tweak It," November 1997). It's more expensive, but it's also several times more powerful than PhotoDeluxe and runs on a 68030 processor with just 2MB of RAM. Now *that's* what I call a low-end image editor.—DEKE MCCLELLAND

Art Dabbler 2.1.1

RATING: ★★★ **PROS:** Turns photos into painterly artwork; includes online drawing guides. **CONS:** Excessive hardware requirements; little more than a subset of Painter's capabilities. **COMPANY:** Meta-Creations (805/566-6200, www.metacreations.com). **LIST PRICE:** \$49.

LivePix 1.1

RATING: ★★ **PROS:** No chance of harming original image files; fully editable text. **CONS:** Excessive hardware requirements; poky screen redraw; complicated, awkward interface; OS 8 conflict. **COMPANY:** The LivePix Company (415/908-1067, www.livepix.com). **LIST PRICE:** \$49.

PhotoDeluxe 2.0

RATING: ★★★ **PROS:** Flexible gallery feature; walks novice users step-by-step through image manipulation. **CONS:** Limited capabilities; intermittent interface display problems. **COMPANY:** Adobe Systems (408/536-6000, www.adobe.com). **LIST PRICE:** \$49.

RATING: ★★★★ **PROS:** ETRN, for nondedicated server connections; POP3 bridge; list server, client-setup wizard; fax and pager gateways. **CONS:** Weak remote administration; requires PowerPC computer. **COMPANY:** CE Software (515/221-1801, www.cesoft.com). **LIST PRICE:** Five users, \$380; 25 users, \$1,200; 100 users, \$4,000.



Magical Pixel Tour If you so desire, PhotoDeluxe will walk you through every process step-by-step. Here, I've asked PhotoDeluxe to help me crop an image down to its most essential elements—namely, the three kids looking up at the fireworks.

to perform the steps or not. PhotoDeluxe gives you a leg up, but you're always the one in control.

PhotoDeluxe gets big points for ease of use, but I wish I could do more with it. There's no way to lighten or darken the medium colors in an image (the so-called *gamma*), making it almost impossible to correct brightness properly. And when sharpening the focus of an image, you have no control over the intensity of the effect. Both of these exceedingly important operations could have been handled very simply without burdening novices with unintelligible controls.

Macworld's Buying Advice

At the risk of sounding like a grizzled old curmudgeon, I must say that I remember a time when programmers took special care to make their software compatible with low-end machines. As late as 1992, for example, every major graphics program listed the Mac Plus—by then seven years old—as its minimum system requirement. Today, even \$49 consumer products refuse to run on a four-year-old Quadra. Let's face it, there's simply no excuse for the fact that Photoshop runs just peachy on a PowerBook 540c, but Art Dabbler and LivePix—which are perhaps 10 percent as capable—won't even launch. PhotoDeluxe is considerably more realistic in

Introducing P²C²™ the PANTONE Personal Color Calibrator™

HOW THE WORLD AGREES ON WHAT IT SEES



Personal Color Calibrator™
Color Accuracy for your Monitor

Achieve perfect color balance in less than 3 minutes! Finally, an inexpensive and easy way to match your on-screen images to your printed output and the Internet, too. The P²C² color calibrator couldn't be simpler to use; just install the software and answer a few simple questions about the way you see color. P²C² then creates sophisticated color profiles (ICC*) for you. Suddenly, and without compromise, your printed images look exactly like they did on your screen, precisely the way you designed them.

PANTONE Personal Color Calibrator
Works with Mac or Win95/NT and all major applications.
\$59⁹⁵

To order:
call **888-PANTONE**
or visit **www.pantone.com**.

PANTONE®

*ICC profiles are the powerful industry standards for color calibration and matching between different devices.
All trademarks (TM) and registered trademarks (®) used herein are either the property of Pantone, Inc., Sonnetech, Ltd. or other companies.
Process color reproduction may not match PANTONE®-identified solid color standards. Refer to current PANTONE Color Publications for the accurate color. © Pantone, Inc., 1997.

Circle 15 on reader service card

PowerBook G3

SPEED CHAMP NEEDS TWO HANDS, TOO MUCH MONEY

DESPITE COMPETITION FROM the PC-laptop world, Apple Computer still makes the fastest laptop on earth: the PowerBook G3. By a happy coincidence, the speedy PowerPC 750 chip inside Apple's popular G3 desktop machines gives off very little heat, making it a natural for use in a laptop. The resulting PowerBook is identical to the heavy, luxurious PowerBook 3400 (see *Reviews*, May 1997) in

PowerBook blow past its predecessor—and all of its Pentium rivals.

The G3 comes decked out with top-of-the-line extras. The 5GB hard drive ought to keep Adobe Photoshop gurus happy for a while (especially since it's 38 percent faster than previous PowerBook drives). The 20× CD-ROM is also a bump up from past offerings (although the "x" number is mostly meaningless—commercial discs are generally mastered to play on 4× drives, max). According to Apple, the PowerBook G3's glorious 12.1-inch screen updates itself 74 percent faster than the PowerBook 3400's, and there's more video RAM—enough to fill an 832-by-624-pixel monitor at the "millions of colors" setting or a 1,024-by-768 screen at "thousands."

Otherwise, the PowerBook G3 is the same as the 3400, warts and all. You still can't display a different image on an external monitor, and even with all that VRAM, you can't set the PowerBook's own screen to anything higher than "thousands of colors." You still get four speakers, a two-hour battery, and an ingenious Ethernet/33.6-Kbps-modem jack that accepts whichever connection you plug in: 10BaseT cable or phone line. And as before, you can exchange the floppy drive and CD-ROM unit—plus VST Zip drives (see the review elsewhere in

this issue) and other add-ons—without having to put the laptop to sleep.

Macworld's Buying Advice

Faster than most desktop Macs, this laptop requires little lowering of expectations; once it's in front of you on a sturdy-legged table, using this machine is pure joy. Productivity applications—even Microsoft Office 98—launch nearly instantaneously, Web pages appear as fast as they download (despite the built-in modem's lack of 56.6-Kbps speed), and even games get a kick from this high-horsepower multimedia deck.

But the G3 is a behemoth; at 8 pounds (with CD-ROM and power plug), lugging this thing around is like hauling a barbell in your briefcase. If you've ever handled Apple's sleek, ultralight winner, the PowerBook 2400c, you'll find that the requirement to lift the G3 with two strong hands is especially disappointing.

And then there's the price: you'd be nuts to pay \$5,700, especially when sources are saying that one of Apple's new PowerBooks, slated for April, will offer the same speed, a slimmer case, a larger screen, a faster modem, and a battery with longer life—for \$2,000 less. (See "New Laptops on Course," *News*, March 1998.) In other words, owning a PowerBook G3 is highly recommended, but *buying* one isn't.—DAVID POGUE

RATING: ★★★ **PROS:** Awesome speed; bright 12.1-inch screen; built-in Ethernet/modem jack. **CONS:** Heavy; limited video features; too expensive. **COMPANY:** Apple Computer (408/996-1010, www.powerbook.apple.com). **LIST PRICE:** \$5,700.



every respect except one: the PowerBook G3 is nearly twice as fast.

How can this be? After all, the G3's official megahertz rating is "only" 250 (compared with the PowerBook 3400's 240MHz rating). But the new model's faster circuitry, bigger/faster/closer high-speed memory cache, and superior PowerPC 750 design make this new



PowerBook G3: Apple's Speediest Portable Yet

Best overall performance. Longer bars are better. Bold indicates best results in a specific test. ▶ New system. An Apple Power Macintosh 7100/80 has a SpeedMark score of 1.0.

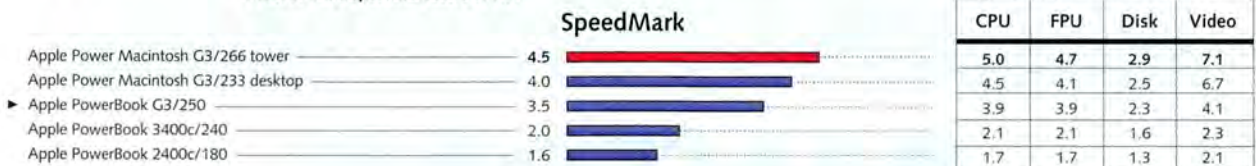

Behind Our Tests

For detailed information on our systems benchmarks, see *Mac SuperGuide*, September 1997, or www.macworld.com/tests/.—Macworld Lab testing supervised by Gil Loyola



This EPS image was printed on an inkjet **without** StyleScript



This EPS image was printed on an inkjet **with** StyleScript

The difference always raises a lot of eyebrows



Adobe PostScript

If you've been using your inkjet to print EPS clip art and graphics, you've probably seen the "jaggies". StyleScript is an easy to use solution that eliminates jaggies by turning your printer into a genuine Adobe PostScript printer.

For only \$99, you'll be able to print:

- ◆ crisp clean EPS images
- ◆ sharp PostScript fonts at any size
- ◆ improved screen/dither patterns
- ◆ more accurate color

StyleScript supports inkjets from Apple, Canon, Epson, and Hewlett-Packard.

StyleScript turns your inkjet into a genuine Adobe PostScript printer



NOW
supports the
Canon 4550, featuring
tabloid-size printing
and the new
StyleWriters



Call now: 800-865-5501
or come visit us: www.infowave.net

StyleScript®

Circle 32 on reader service card



Dreamweaver

DYNAMIC HTML NO LONGER JUST A DREAM

THE NEW DYNAMIC HTML technologies supported by Netscape Navigator 4.0 and Microsoft Internet Explorer 4.0 offer some exciting new capabilities—cascading style sheets, absolute positioning, and JavaScript-based animation, to name a few—but they require a lot of complicated programming. Macromedia's Dreamweaver 1.0 is the first major program that lets you use DHTML while shielding you from its underlying complexities. Dreamweaver's design capabilities and respect for clean HTML should bring smiles to the faces of designers and code geeks alike.

DHTML Dynamo

In Dreamweaver you create DHTML animations by placing text and images on movable layers that can fly across the screen. You can then manipulate those layers in a Timeline Inspector reminiscent of that in Macromedia Director. The program includes several *behaviors*, canned JavaScripts that automate common tasks. Adding behaviors is easy: you simply select text or an image and choose the desired behavior from a palette, and Dreamweaver adds the appropriate JavaScript to the page. If you know how to program in JavaScript, you can create your own behaviors.

Dreamweaver provides very good support for cascading style sheets. You can define text styles that can then be used throughout your document, or you can create external style sheets that are referenced by all pages in your site; changing a style definition automatically changes all instances of that style.

While other programs position text and images precisely on a page by creating complex tables, Dreamweaver uses the much cleaner DHTML absolute positioning. But because absolute positioning works only in version 4.0 browsers (which fewer than half of Internet users have), it's easy to create pages that look great in current browsers and awful in last year's model. And aside from its DHTML features, Dreamweaver isn't as capable a design tool as competitors like GoLive's CyberStudio or NetOb-

jects Fusion; in this respect it bears a closer resemblance to the simpler Claris Home Page.

One nice feature in Dreamweaver is Roundtrip HTML: you can edit a page either graphically or in the HTML source code, without having the graphic editor rewrite changes made in the HTML source code as competing programs do. Compared with other programs, Dream-



New Arrivals Dreamweaver's animation support brings a Director-style Timelines window to Web-page design. Each image in the top frame is flying into the frame under the timeline's control.

weaver generates tight, clean HTML that's easy to edit by hand. A good HTML source editor is built in, as is Bare Bones Software's BBEdit 4.5. Buttons in both programs let you bounce back and forth easily between the two.

In an attempt to generate pages that work in most browsers, Dreamweaver writes extra HTML and JavaScript that takes into account the differences between Navigator and Internet Explorer. Most of the time the program succeeds admirably at this difficult task; it checks your pages' syntax against browser profiles and generates a report listing the features of your site that will cause errors.

The Wrong Tool for Site Architects

Dreamweaver is good at building pages but weak when it comes to building sites. Unlike CyberStudio and Fusion, it offers minimal site-management capabilities; it simply maintains a site on a local drive that's an exact duplicate of the site on the remote server, checking the server periodically for changes. If you accidentally break a link, Dreamweaver won't help you

find it or fix it automatically. And clicking on a link to another page in your site—a good way to check links—doesn't open that page. In addition, the program lacks a graphical site overview showing links between pages.

On the other hand, Dreamweaver has an innovative system for managing group collaboration on a Web site, something that's notably missing in competing programs: it locks files that a user has "checked out," preventing someone else from changing them at the same time. That keeps, say, an art director from modifying a page to which a coder is adding JavaScript behaviors.

Dreamweaver's performance is fine in some areas but mediocre in others. The Site window, for example, shows both the remote and local copies of a site, so every time you open a local page there's a delay while Dreamweaver checks the remote site for changes. The program is also a bit of a RAM hog, asking for 17MB of memory (although 20MB is preferable).

As a complex, professional-level tool, the PowerPC-only Dreamweaver requires significant time to master. Getting up to speed would be easier if the printed documentation were better—the skimpy user manual is accompanied by HTML and Shockwave help files that are extensive but lack an index. The program also needs some interface refinement: the array of palettes can be bewildering, and you often need to open several dialog boxes to complete a task.

Macworld's Buying Advice

Dreamweaver's debut kicks off the next round of competition in the field of high-end Web page editors. If you've been looking to add DHTML to your sites but want to avoid the complexity of style sheets and JavaScript, Dreamweaver is a good choice. Just remember that if your users don't have the latest browsers, many of Dreamweaver's flashy effects will be for naught—TOM NEGRINO

RATING: ★★★½ **PROS:** Supports Dynamic HTML; excellent access to underlying HTML; includes BBEdit 4.5. **CONS:** Poor site management; needs better documentation; RAM hungry; quirky interface. **COMPANY:** Macromedia (415/252-2000, www.macromedia.com). **COMPANY'S ESTIMATED PRICE:** \$499 (\$299 through February 28).



STAMP OUT RETYPING WITH THE WORLD'S MOST ACCURATE OCR.

New OmniPage Pro 8.0. Over 99% accurate*—guaranteed!

Don't retype another letter, report, fax or article into your computer ever again. New OmniPage Pro 8.0 for Macintosh easily converts your scanned pages into editable text and graphics in seconds. Which means you can quickly input text into your favorite applications like Word, WordPerfect, Excel and others. OmniPage Pro 8.0 is a quantum leap



The AutoOCR Toolbar™ performs OCR with a single click.

"OmniPage Pro is as good as it gets."

MacWeek January 27, 1997

forward in OCR accuracy, even when compared to version 7.0. What's more, it offers dramatic accuracy improvements when you OCR poor-quality documents — faxes, small text, skewed pages, reversed-out type, bad copies and more.

Don't settle for anything less than the most accurate OCR in the world. Call now to order, or visit your local reseller today. Who knows, they may even let you trade in your old keyboard.

- Easy-to-use, one-click OCR
- Maintains original page layout
- Now saves color images in color—not black and white
- Proofreads OCR results
- Seamlessly integrates with Microsoft Word
- OmniPage Guide provides comprehensive online help
- Outputs to HTML 3.0, and more!

UNIVERSAL UPGRADE

\$129**

SAVE OVER 75%
SPECIAL UNIVERSAL
UPGRADE FOR ALL
SCANNER OWNERS!

800-736-5735 x.80



*Using standard fonts on laser-quality documents. If for any reason you are not satisfied that OmniPage Pro 8.0 dramatically improves your OCR accuracy, return it for a full refund (less shipping and handling). **Suggested price US dollars—subject to change without notice. Offer valid in US and Canada only. Caere, the Caere logo, OmniPage, and OmniPage Pro are registered trademarks and AutoOCR Toolbar is a trademark of Caere Corporation. All other names are the property of their respective holders. © 1997

Circle 69 on reader service card

Midrange Digital Cameras

KODAK PROVES THE BEST OF A GOOD SUB-\$1,000 BATCH

IF NOTHING ELSE, *MACWORLD'S* first roundup of digital cameras for 1998 proves that there's no reason to put up with 640 by 480 pixels anymore. Of the four models discussed here, three sport an image resolution of at least 1,024 by 768 pixels (equivalent to the default resolution of a 19-inch monitor), and just one, the Panasonic CoolShot KXL-601A, tops out at 640 by 480 pixels (13-inch resolution).

Yet despite the fact that the CoolShot provides fewer than 40 percent as many pixels as its competitors, its estimated street price of \$599 is just \$100 less than that of the first of the high-resolution models we'll look at, the Olympus D-320L. And for \$300 more than the CoolShot, you can purchase the Kodak DC210 with its brilliant array of 1,152 by 864 pixels (just shy of the resolution of a 21-inch monitor). Granted, \$300 is nothing to sneeze at, but if you consider the price per pixel, the DC210 costs less than half as much as

the CoolShot—and those cheaper pixels are in a heck of a lot better shape!

One of Q's Lesser Efforts

In the spirit of getting on with the good stuff, I'll dispense with the worst of the cameras first. The CoolShot KXL-601A is actually two pieces of hardware: a pocket-size camera unit (sold separately for \$399 as the KXL-600A) and a detachable LCD viewfinder. On its own, the KXL-600A looks like the sort of sleek platinum spy camera that the fictional gadgetmeister Q might have created for James Bond. But after a few hours of beta testing on the bad guys, 007 would have found plenty to beef about. The camera combines a wretchedly inaccurate viewfinder with poor image quality. It lacks a flash, but it's utterly incapable of taking pictures under low-light conditions.

And although the CoolShot is too dumb to automatically account for dramatic variations in light and focus, it's

smart enough to scold you when you fail to anticipate the variations manually. I'd hate to be in Q's shoes when James returns from "The Beepy Camera Mission."

The KXL-601A's LCD attachment addresses the inaccurate viewfinder problem, but it also doubles the camera's dimensions and weight. Without the LCD, the CoolShot is elegant but inept; with the LCD, it's just plain clunky. As a final snub, Panasonic assumes you own a PC. If you want to attach the CoolShot to your Mac, you'll need to purchase the special KXL-D43 interface kit. For \$59, you get a cable and a floppy disk. Not even archvillain Jaws gouges that deep!

Pick a Camera, Any Camera

In stark contrast to the CoolShot, the remaining devices are easily the three best digital cameras under \$1,000 that I've seen. Naturally, each camera has its own peculiar quirks, but it's no exaggeration to say that you can't go wrong with any of them. The Kodak DC210 earns the highest mouse rating, thanks to its superior image quality, but if you find a good deal on the Olympus D-320L or Epson PhotoPC 600, then by all means, purchase without hesitation.

Digital Cameras Under \$1,000

Company	Epson America	Kodak	Olympus America	Panasonic
Product	PhotoPC 600	DC210	D-320L	CoolShot KXL-601A
Mouse rating	★★★★	★★★★½	★★★½	★★
Estimated street price	\$699	\$899	\$699	\$599
Phone number	310/782-0770	716/726-7260	516/844-5000	201/348-7000
Web address	www.epson.com	www.kodak.com	www.olympus.com	www.panasonic.com
Dimensions (w × h × d, in inches)	5.6 × 2.8 × 1.9	5.2 × 3.2 × 1.9	5.0 × 2.6 × 1.8	1.0 × 5.3 × 2.7 (1.9 wide with LCD)
Weight (with batteries, in ounces)	13	15	12	7 (13 with LCD)
Maximum image size (in pixels)	1,024 × 768	1,152 × 864	1,024 × 768	640 × 480
Default memory	4MB	4MB [*]	2MB ^{**}	2MB [*]
Expandable media format	CompactFlash	CompactFlash	SmartMedia	CompactFlash
Maximum storage capacity (in images) ^{***}	16	19	10	24
Closest focal distance (in inches)	8	8	8	5
Optical zoom function	no ^{***}	yes (2x)	no	no
Built-in flash/red-eye setting	yes/no	yes/yes	yes/yes	no/no
LCD preview and playback	yes	yes	yes	optional
Optical viewfinder	yes	yes	yes	yes
Adobe Photoshop acquire module	no	yes	yes	no
Rechargeable batteries with charger	yes	no	no	no
Macintosh connectivity	yes	\$25 extra	yes	\$59 extra

^{*} Expandable media; no on-board memory. ^{**} Maximum image size, medium quality. ^{***} 3x digital zoom only

The Olympus D-320L and Epson PhotoPC 600 are equivalent in a half-dozen respects. For starters, both cameras capture sharply focused, highly saturated images measuring 1,024 by 768 pixels. In fact, photographs taken with the two cameras are virtually indistinguishable, tending toward slight yellow casts. Both cameras include an attached lens cover, minimizing your need to clean the lens. To turn the camera on, just open the lens cover and away you go. And both cameras include Macintosh cables and software as part of the base package.

But the PhotoPC 600 offers a handful of noteworthy advantages over the D-320L. First, the PhotoPC 600 includes 4MB of on-board memory with optional expansion via CompactFlash cards (essentially miniature PC Cards). By contrast, the D-320L ships with 2MB of memory on a wafer-thin SmartMedia card that you have to swap out to expand. The PhotoPC 600 offers more compression options than the D-320L, and it's the only mid-range camera that lets you shoot both in color and in black-and-white. In terms of camera controls, the PhotoPC 600 remembers its settings from one session to the next, something neither the D-320L nor Kodak's DC210 does.

Another distinction is power. Epson bundles four rechargeable NiCd batteries and a compact charger with the PhotoPC 600; the other cameras ship with single-shot disposables. To make sure your batteries last a long time between charges, PhotoPC employs a more deliberate LCD design. You slide a switch to activate the LCD screen, compared with pressing a button on the D-320L. This may sound like a minor distinction, but it means the D-320L's LCD has a habit of turning on by itself and wasting precious battery power every time it's pressed up against another object in your camera bag or briefcase.

King of the Midrange Pack

Last year, I was one of the very few voices critical of Kodak's previous effort, the DC120 Zoom (*Reviews*, October 1997), and the excellent performance of the DC210 confirms my criticism. Kodak's new camera isn't merely more stable than its predecessor, it's redesigned from the ground up. Where the older DC120 captured images to an 850-by-984-pixel CCD and then interpolated the



Still Life with Blowout Although I photographed this tire early one winter afternoon, the light was sufficiently low to set off the automatic flashes on all cameras but the CoolShot (A), which has no flash. The DC210 (B) produced the most vivid image, with the D-320L (C) and PhotoPC 600 (D) serving up slightly more muted colors. All three cameras did a great job of conveying the depth of the elements and the frayed edges around the tubing. The only washout among these images is the CoolShot's, which appears murky and irregular.

data horizontally to 1,280 pixels wide, the DC210's improved CCD captures a full 1,160 by 872 pixels and crops away the edges. The result is a crisper, sharper, and more colorful photograph without any of the grain associated with DC120 snapshots. In fact, the DC210 produces what are without a doubt the best images of any digital camera under \$1,000 (see "Still Life with Blowout").

The DC210's other specs are interesting if not exceptional. With the DC210, Kodak has forsaken the boxy design of the DC50 and DC120 in favor of an upright housing. And it's alone among the four cameras reviewed here in providing a continuous optical zoom. (The PhotoPC 600 provides a stepped 3x zoom, but it's merely an interpolated digital effect similar to what you'd get by upsampling in Adobe Photoshop.) On the downside, Kodak's LCD preview is, as usual, grainy and jerky when compared with the picture-perfect screens built into the D-320L and PhotoPC 600. And the DC210 lacks a lens cover, making it easy to gum up the lens with fingerprints and the like.

Macworld's Buying Advice

If image quality is your main criterion, then Kodak's DC210 wins hands down,

not only among the four cameras reviewed here but among all 26 consumer models I've used in the past four years. If image quality is high on your list but usability is job number one, then I'd have to recommend Epson's PhotoPC 600. In fact, on a recent occasion when I needed to shoot some emergency pictures and deliver them in a hurry, I automatically grabbed the PhotoPC 600 for its splendid LCD preview, settings memory, and 4MB image capacity. The D-320L is no slouch, and at \$200 less than the DC210 it's obviously the most economic choice.

Incidentally, before you walk into your neighborhood camera or computer store, you might want to jot down the exact model names and numbers of the cameras you're interested in. Olympus produces lesser cameras with D's and L's in their names, and Epson's previous PhotoPC incarnations bear virtually no resemblance to the much-improved 600. (To make things additionally confusing, Olympus recently announced its own "600" model—the \$1,299 D-600L SLR zoom camera—which we'll review in a later issue.) Meanwhile, Kodak's other DC models—particularly the DC120—leave much to be desired.—DEKE McCLELLAND

Tax-Preparation Software

MACINTAX AND KIPLINGER TAXCUT CALM TAX ANXIETY

THIS YEAR'S BIG TAX-LAW CHANGES can save you money, but they'll also complicate your filing chores. Fortunately, this year's tax-prep software, Intuit's MacInTax Deluxe and Block's Kiplinger TaxCut, have kept up with the new laws and help you understand how to save money for current and future tax years. Both programs use similar methods of asking you questions and filling in dozens of tax forms based on your answers. But MacInTax proves to be easier to learn, with its helpful method of collecting tax-code information, intense interview process, and simpler techniques for correcting errors.

A Less Taxing Procedure

Both programs gather information by interviewing you. The interview question and answer fields appear in the top part of the screen, and tax worksheets appear underneath. Advanced users can always skip the interview and enter directly on tax worksheets. (Luckily, you don't have to type everything in, as both import data from Quicken and other financial software.)

Although both products use overview windows to jump from one major topic heading to another, MacInTax gives you more viewing room by keeping its overview window hidden—it's accessible via a button when you need it.

Since both programs calculate your taxes in a few seconds, be prepared to spend most of your time answering the interview questions. Occasionally, TaxCut's questions aren't as thorough or clear as MacInTax's, and often TaxCut involves more tedious steps. For instance, where MacInTax uses a single screen containing a dozen fields for different types of Schedule E rental expenses (repairs, property taxes, and so on), Kiplinger TaxCut requires you to click through a page for each item.

Even with the extensive interviews, tax-prep software doesn't make income-tax preparation automatic—the tax code requires you to make technical decisions, such as selecting methods of depreciation. Both programs offer hypertext definitions of tax terms, and lots of tax and reference information with links to Web-based info.

However, MacInTax integrates more



Tax on a Mac MacInTax's QuickTime movies explain the finer points of the 1997 tax code (top). Like MacInTax, Kiplinger TaxCut interviews you, but it also lets you jump between topics (bottom).

tax information into the interview process by offering reminders. For example, when you enter non-W-2 income, MacInTax warns you that if you received a cash payment of more than \$10,000, you must report it on Form 8300. Kiplinger TaxCut offers some of this kind of information, but not nearly as much.

As in previous versions, MacInTax uses QuickTime movies to explain the program and more complex tax-code issues. Many movies are helpful in conveying information on topics such as the new capital-gains rules, the difference between direct and indirect expenses for a home office, and the new health-insurance deductions for the self-employed. TaxCut also covers these topics but sticks to text, and in some cases gives you only the IRS's dry explanations.

Double-Checking

Both programs check your documents for errors. TaxCut checks your tax forms at the end of the interview process, or you can manually select the Audit command

from the Tools menu. A button takes you to a worksheet where you can change your entry, so you don't need to step back through the interview to correct data.

Although TaxCut's technique is effective, fixing problems is easier in MacInTax. At the end of each major form, MacInTax reviews the document and prompts you to save the data. In one test, I entered the same Social Security number for spouse and child. Kiplinger TaxCut found the error and a button brought me to the worksheet with the child's number, but it was difficult to find where to change the spouse's incorrect number.

Another nice feature of MacInTax is the ability to calculate the maximum Keogh or SEP contribution allowed based on your earnings. The amount you enter changes the amount of your tax due or refund, so you can find an optimal amount.

MacInTax has one annoying quirk: you need to have the CD-ROM in your Mac to run the application. TaxCut also comes on a CD-ROM, but thankfully it's only required during installation.

Both programs let you file your taxes electronically with the IRS without additional cost. However, veteran users accustomed to "planning" versions should note that these editions aren't available this year.

Macworld's Buying Advice

MacInTax Deluxe costs a bit more than Kiplinger TaxCut, but it is easier to use. The step-by-step explanations, combined with the data filtering, in either of these programs gives you a good handle on the new changes in tax code.—JOHN RIZZO

Kiplinger TaxCut 1997

RATING: **★★★★** **PROS:** Straightforward interview process; up-to-date tax information; good performance. **CONS:** Sometimes difficult to fix errors. **COMPANY:** Block Financial (800/235-4060, www.taxcut.com). **LIST PRICE:** \$29.95; state modules, \$24.95 each.

MacInTax Deluxe 1997

RATING: **★★★★½** **PROS:** Easy to use and navigate; comprehensive interview process; easily accessible tax-code information. **CONS:** Requires CD-ROM in drive to run. **COMPANY:** Intuit Software (520/295-3110, www.macintax.com). **LIST PRICE:** \$49.95; state modules, \$24.95 each.

YOU'VE ALWAYS BEEN AN ORIGINAL THINKER.
JUST DON'T GET TOO CREATIVE WHEN YOU'RE
CHOOSING MEMORY.



NOT CONCERNED about your brand of memory? It's time to "think different." The fact is, the new high-performance Macs require high-performance memory such as SDRAM (synchronous DRAM). Consequently, www.kingston.com/ad timing errors as small as a nanosecond can lead to data corruption. That's why Kingston® imposes stringent design controls to regulate timing, such as matching trace lengths to ensure proper synchronization of data. And since we're an authorized Apple® RAM developer, our memory will always be 100 percent compatible with your Mac®. To find out more, call your preferred reseller or Kingston at (800) 259-8965. Or visit our Web site. We promise not to tell people that you're playing it safe.

Kingston
TECHNOLOGY

COMPUTING WITHOUT LIMITS.™



Kingston Technology Company, 17600 Newhope Street, Fountain Valley, CA 92708 USA, (714) 435-2600, Fax (714) 435-2699. © 1997 Kingston Technology Company. All rights reserved. Computing Without Limits is a trademark of Kingston Technology Company. Apple and Mac are trademarks of Apple Computer Inc., registered in the U.S. and other countries. All other trademarks and registered trademarks are the property of their respective owners.

Circle 201 on reader service card

Bryce 3D

ANIMATION ENLIVENS 3-D TERRAIN GENERATOR

NOT CONTENT WITH THE CAPABILITIES of its already impressive terrain generator, MetaCreations has added an assortment of tools and features to the latest version of Bryce. (Not content with the name either, the company is now calling it Bryce 3D, which is somewhat puzzling since the program has always produced 3-D scenes.) The new version gives you more control over the appearance of clouds, water, and material textures and, most notably, lets you animate the scenes you create. The additional controls, plus a greatly enhanced manual, make Bryce 3D even more pleasurable to use.

Making a Scene

In case you're not familiar with Bryce (and don't have a copy of *Macworld's* August 1996 review of Bryce 2 handy), this Power Mac-only program lets you create fanciful or realistic landscapes in 3-D space. You can import DXF, 3DMF, and OBJ objects into Bryce landscapes; use preset terrains, water, skies, textures, and Boolean objects; or customize the preset elements in one of the program's many editing environments. For example, you can use the Terrain Editor to make peaks craggier or smoother and the Materials Editor to select the rock they're made of. You can adjust attributes, such as lighting or viewing angle, and fine-tune details ranging from the amount of haze in the sky to the reflectivity of an object. You save your finished scenes as Bryce files or export them as PICT, QuickTime, QuickTime VR, or Adobe Photoshop 3 files.

Before Bryce renders a scene, you can preview it as a thumbnail, wireframe, or low-resolution image. If all you want to do is quickly check the appearance of a lighting change or custom texture, you can render just a portion of the scene. Rendering can take hours, depending on the image's complexity, but the manual offers strategies for speeding up rendering; for example, if you delete an object from a scene, you may be able to rerender just the area the object occupied.

Bryce 3D's user interface is somewhat unorthodox. For instance, dialog boxes

present a check mark for "OK" and an X for "Cancel," and some of the editing controls have you slide the pointer over a



Add a Little Atmosphere Bryce 3D's Environmental Attributes palette lets you add effects such as rainbows, star fields with comets, and rings around the sun or moon.

sort of on-screen trackball. The graphically oriented controls take some getting used to, but once you become fluent with them, it's easy to edit and preview a scene. For the most part, Bryce is cleverly designed; auxiliary features are hidden away until you select them, avoiding on-screen clutter.

Impressive New Effects

Among Bryce 3D's new features is the ability to apply a texture to the entire volume of a 3-D object rather than just its surface, a useful way to create clouds and underwater scenes that can be penetrated by objects, cameras, or lights. New controls let you fine-tune the appearance of clouds and add environmental effects; a "horizon effect" makes the sun or moon appear larger when it's at the horizon. The new version also lets you add visible light sources and "infinite slabs," planes with depth that you can use to create realistic bodies of water.

With the new Deep Texture Editor, you can make minute adjustments to a texture's color, bright and dark areas, and bump pattern. Although the fairly complex controls can be a bit intimidating at first, the manual devotes an entire chapter to texture editing, and you can preview your changes as you make them.

Bryce 3D's most impressive new features are in the realm of animation. Effective, easy-to-use tools let you animate objects in a scene and generate fly-through animations by controlling the position of a camera. You can also animate materials by manipulating how an object's or terrain's surface reacts with light, producing the fading light of a sunset, bubbling lava, a shimmering lake, or a slowly appearing rainbow.

To animate objects or the camera, you set the animation's duration and specify keyframes; Bryce fills in the intermediate frames when it renders the animation. For variable-speed animations—a bouncing ball that changes velocity, for example—the Advanced Motion Lab lets you remap keyframes to create velocity effects. To animate a material, you set two frames (the beginning and final material) and Bryce interpolates between them to create a smooth transition.

One of my main complaints about earlier versions was the skimpy manual. A solid, 450-page tome corrects that deficiency, with tutorials, detailed descriptions of features, and a thorough index (although it could use another round of copyediting).

Macworld's Buying Advice

Bryce 3D is one of those rare graphics programs that can produce impressive results for artists and nonartists alike. A dabbler can throw together some preset objects and terrains, fiddle with the lighting a bit, and produce a respectable photo-realistic landscape, while an artistically inclined Bryce user can take advantage of the program's advanced features to create some spectacular scenery. The additional features in Bryce 3D give artists more ways to customize the elements that make up their landscapes, and the new animation tools make the program even more fun. —ERFERT FENTON

RATING: ★★★★★ **PROS:** Better control over material editing; new animation tools; better manual. **CONS:** None significant. **COMPANY:** MetaCreations (805/566-6200, www.metacreations.com). **COMPANY'S ESTIMATED PRICE:** \$199.

Permission to Engage

TOP GUN™

FIRE AT WILL

You are **Maverick**-
and you've got
your orders on your
mind, Commander
Hondo
on your back and
MiGs on your tail.
So fuel up.
Strap yourself in.
And let 'em know your **bark**
is nothing...
next to your **bite.**



High-resolution voxel engine creates a photo-realistic experience

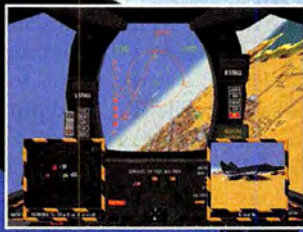

Lead your wingmen into fierce dogfights and air-to-ground combat in over 40 missions



Only the best of the best graduate from Top Gun



Training missions at the Naval Air Station at Miramar prepare you for intense combat

TOP GUN © 1997 Paramount Pictures. All Rights Reserved. Spectrum HoloByte is an authorized user. Spectrum HoloByte is a registered trademark of Spectrum HoloByte, Inc. MicroProse is a registered trademark of MicroProse, Inc. or its affiliated companies. All other trademarks are the property of their respective holders.

MICROPROSE

800-229-2714

Call for a free catalog or visit our website at www.wizworks.com

MacSoft®

An Affiliate of **Wiz Interactive Software**
2300 Berkshire Lane, Pittsburgh, PA 15201 612-509-7600

Circle 23 on reader service card

Creator2

NEW PAGE-LAYOUT PROGRAM RIVALS QUARKXPRESS

YOU CAN'T HELP BUT BE SKEPTICAL of a program that dares to challenge professional-quality, industrial-strength tools such as QuarkXPress and Adobe PageMaker. But Multi-Ad Services' new page-layout system, Creator2, offers enough in the way of typographical precision and high-end graphics support to impress even the toughest customers in the desktop-publishing world. Although it's based on Multi-Ad Creator, a heavy-duty display-advertising-design program that's been a mainstay in the newspaper industry for years, Creator2 is flexible enough to handle a variety of documents.

Typographical Tools

Creator2 looks and feels a lot like QuarkXPress: You compose pages by drawing boxes and then typing (or importing) text to fill them; you can import graphics in a variety of standard formats and draw page elements, such as rules and frames, using built-in drawing tools.

In the way it handles these tasks, Creator2 proves itself to be a professional-caliber tool that lets you manipulate page elements quickly and powerfully. With Creator2's copy-fitting commands, for example, you can automatically grow text to fill a text box or resize a box so the text fits precisely. Another beautifully streamlined tool is the Make Matrix command; it lets you arrange a series of linked text boxes on a page without having to draw them one at a time or duplicate and then link them manually, an approach that dances circles around QuarkXPress's Step and Repeat command. Adding to the program's flexibility is support for multiple page sizes—you can create projects with a variety of page sizes within a single document, something QuarkXPress can't do.

Creator2 also offers a great deal of typographical precision. You can adjust leading and tracking and kern text to within 1/1,000 of an em, for example, and you can apply such effects as changing the slant and weight of characters and adding shadows to text. Although Creator2 owes much of its typographical precision to QuickDraw GX, you *don't* have to install that program or switch to

QuickDraw GX fonts; the GX Graphics system extension included in Creator2 lets you tap into the GX technology with-

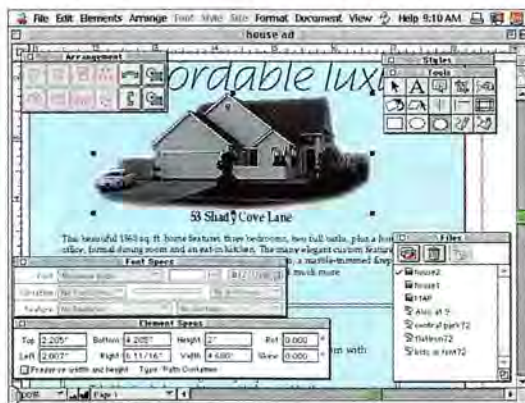

Batch Importing You can import a batch of images into Creator2's Files palette (lower right) and then add the listed files to document pages by dragging the images into place.

out having to reinstall printer drivers and fonts. But while the GX Graphics extension adds compatibility, it increases the potential for system conflicts.

Unfortunately, not all of the typographical controls are easy to access. You can adjust some settings through the Font Specs palette, but leading and tracking are tucked away in a dialog box. On the positive side, you can use AppleScript to automate a number of formatting tasks; Creator2 isn't just scriptable, it's recordable, making it easy to build your own scripts.

Graphics Support

Like QuarkXPress 4.0, Creator2 includes a full set of Bézier drawing tools to create boxes, frames, rules, and other elements of any shape. Both programs let you convert text into boxes, which you can then fill with colors, pictures, or more text. Creator2's tools aren't quite as powerful or sophisticated as those in QuarkXPress—for example, you can't bind text to a curved path. Its built-in masking features are particularly strong, however. Choose the Mask Graphic command with an imported picture selected, and Creator2 creates an editable mask around the picture so you can selectively crop out parts of the picture.

In Creator2, any object can become a container for another object. For example,

using the Containment tool, you can drag a text box into a starburst shape and hold down different keys to make the text either fill the starburst or be cropped by it. You can then manipulate the two objects as a single element.

For projects that use color, Creator2 lets you not only create separations but also view them on screen—a very helpful proofing tool for professional designers. The program also supports element trapping, so you can create custom traps for any object on a page.

Adding graphics to a project is especially easy with Creator2's Files palette (one of eight palettes that allow access to the program's key commands). You can import an entire folder of images into the Files palette and then add the images to pages simply by dragging them from the palette.

Though rich in features, Creator2 suffers from some surprising omissions. It doesn't support drag-and-drop text editing, you can import formatted text from other word processors only by using the Mac Easy Open or MacLink Plus converter, you can't format text as small caps, and there's no easy way to create drop caps. And Creator2 is clearly not optimized for creating longer documents; the program can't generate an index or table of contents.

Macworld's Buying Advice

Creator2 is the first page-layout application I've seen that is indeed a compelling alternative to QuarkXPress—though the similarly priced XPress is still the better choice. Creator2's dependence on the GX Graphics extension is a bit of a drawback, and some key features seem to be missing, but the program is packed with impressive tools for assembling documents quickly and professionally.—JOSEPH SCHORR

RATING: ★★★½ **PROS:** Strong set of page-layout tools; lets you view separations on screen; good tools for creating matrices of linked text boxes. **CONS:** Some typographical tools are difficult to access; no support for drop caps; no drag-and-drop text editing; requires GX Graphics extension. **COMPANY:** Multi-Ad Services (309/692-1530, www.multi-ad.com). **LIST PRICE:** \$995.

MARVEL
INTER
ACTIVE

X-MEN

THE RAVAGES OF

APOCALYPSE

A QUAKE® TOTAL CONVERSION



Battle Using the Full Array of Weapons, or Fight the X-Men using each Character's Unique Power



Eight New Weapons, Plus 24 X-Men Superpowers



Two Riveting Single-Player Episodes and Four Multi-Player Levels



Incredible New X-Men Graphics

**THIS IS NOT THE GAME OF QUAKE® YOU ONCE KNEW.
THE X-MEN HAVE TAKEN OVER. NOW IT'S A WHOLE NEW GAME.**

This product is in no way affiliated with, nor will it be supported by, Id Software, Inc.

800-229-2714

Call for a free catalog or visit our website at www.wizworks.com

MacSoft®

An Affiliate of GT Interactive Software Corporation

©1997 Marvel Characters, Inc. All rights reserved. Marvel Interactive, X-Men, all Marvel character names and the distinctive likenesses thereof are trademarks of Marvel Characters, Inc. and are used with permission. Quake® is a registered trademark of Id Software, Inc. All rights reserved.

Circle 28 on reader service card

Photoshop Color Plug-Ins

PLUG-INS DELIVER SMALLER FILES, EXPANDED COLORS

ADOBE PHOTOSHOP OWES AT least part of its success to its extensible architecture: third-party plug-ins help users create everything from Web graphics to high-end, multicolor prepress files. Three such packages are BoxTop Software's ImageVice 1.0, a color-reduction plug-in for Web graphics, and Pantone's suite of advanced printing-preparation plug-ins—HexWrench 1.0, and MC-P/CoCo bundled with Channel 24—all designed to expand the color-processing options found in Photoshop.

Squeezing Pixels

Designed to shrink GIF files while preserving image quality, ImageVice reduces colors based on how we perceive color rather than by statistically polling the most common colors in an image. It offers four controls for reducing colors: the



Six Degrees of Separation HexWrench's many options are well organized, and you can trace the flow of image processing by following the vertical lines on the right.

color-depth setting determines the palette for the image; the clipping control forces dark and light colors to black and white; the smoothing control determines the threshold at which one pixel is blended with an adjacent, similar color; and the convergence parameter groups similar colors into horizontal bands and stripes for efficient compression.

Depending on the image and on ImageVice's settings, the resulting GIFs are 25 to 70 percent smaller than comparable GIFs converted using Photoshop's Indexed Color mode. But the negative visual artifacts are obvious, and the lack of zoom and pan controls in the tiny compression preview window makes accurate

previews nearly impossible. Digital Frontiers' HVS Color (see *Reviews*, October 1996) offers not only better previews, visual results, and color-reduction controls, but also the ability to generate either GIFs or JPEGs.

Expanded Palette

Pantone's prepress and color-separation tools help Photoshop deal with alternative printing techniques and file formats. Although they specifically target Hexachrome color separations—CMYK, plus green and orange—these plug-ins can also be used for hi-fi color, spot color, varnish and bump plates, and stochastic screening. They all work in tandem with the SAME (Studio Appearance Management Environment) extension, which attempts to compensate for color differences among scanners, monitors, and printers with SAME profiles.

HexWrench prepares Hexachrome image separations, which you can preview on screen before running expensive film separations or proofs. The program comprises two plug-ins and a stand-alone application. The HexWrench/DCS plug-in allows Photoshop to read and write files in Desktop Color Separation 2.0 format; the HexWrench/PS filter lets you preview Hexachrome separations in Photoshop (a split-screen window lets you compare CMYK and Hexachrome proofs side by side) and save them as DCS 2.0 files. To produce an 8-bit, 72-dpi DCS file and six gray-scale Photoshop EPS images, one for each color plate, you simply click on the Separate button. The stand-alone component, HexWrench/Tuner, calibrates color among devices. Once you've selected a profile, the software formats and prints a test chart that you can then sample with a spectrodensitometer to identify color inconsistencies.

MC-P/CoCo lets you make up to 16 single-color alterations in either CMYK or RGB mode. Each channel can have its own name and color; you can assign alpha channels or extra color channels to Pantone spot colors, varnish layers, and hi-fi and Hexachrome images. The color ranges that MC-P/CoCo selects are antialiased, and the Range parameter

restricts color selections to very specific portions of images. Although the Range parameter offers only ten levels of spreading and you can't use drag and drop to assign the current color value to the target values, prepress professionals will appreciate MC-P/CoCo's expanded color-correction controls.

Channel 24 lets you save and load multichannel images as DCS files. Because it's a plug-in, however, it has no interface for perfecting Hexachrome and hi-fi color files as HexWrench/PS does. And unlike HexWrench/DCS, it lets you alter the color contents of each channel as the file is saved and doesn't necessarily generate Hexachrome separations. Its only drawback is that it lacks a default profile button.

Macworld's Buying Advice

While most designers and artists rarely find themselves producing color separations for Hexachrome or hi-fi printing, those who do will undoubtedly find Pantone's HexWrench, MC-P/CoCo, and Channel 24 a winning combination. ImageVice is fairly good at color reduction, but Digital Frontiers' HVS Color offers better results with more control.

—NATHAN MOODY AND DAVID BIEDNY

HexWrench 1.0

RATING: ★★★ **PROS:** Great control over Hexachrome color separations; full compatibility with ColorSync device profiles; dynamic previews; well-designed interface. **CONS:** Requires prepress knowledge. **COMPANY:** Pantone (201/935-5500, www.pantone.com). **LIST PRICE:** \$499.

ImageVice 1.0

RATING: ★★★½ **PROS:** Good visual results at low settings; simple interface; adequate alternative to Photoshop's color-reduction tools. **CONS:** Discernible artifacts; poor image preview. **COMPANY:** BoxTop Software (601/324-1800, www.boxtopsoft.com). **LIST PRICE:** \$49.95.

MC-P/CoCo and Channel 24

RATING: ★★★ **PROS:** Rapid image previews; useful for last-minute changes to color specs. **CONS:** Poor documentation; color picking could be finessed. **COMPANY:** Pantone (201/935-5500, www.pantone.com). **LIST PRICE:** \$499.



FreeHand 8



Step into the world of motion with FreeHand 8.

The world of design is in motion. Toward more powerful effects, animation, and the Web. FreeHand™ moves your print designs to a new level with tools like editable transparency, a customizable interface that streamlines integration with your other tools, and the industry's fastest redraws. Move into the world of Web design with vector graphics that download quickly with superior quality, anti-aliased text, and support for the leading Web animation tool, Macromedia® Flash™. Get FreeHand 8 alone – or upgrade to the Design in Motion™ Suite, which also includes Flash and Insta.HTML 2 for turning FreeHand layouts into Web pages and save up to \$300. Just call **1 800 457-1774** and mention code 805. Or visit <http://special.macromedia.com/f8/m> for all the details.



Introducing
a **NEW Service** to
Readers...

Macworld
Get
Info

www.macworld.com/getinfo

Macworld's
NEW ONLINE
Reader Service

Introducing Get Info. Now you can get information on all the products and services you see in *Macworld*. Only get it faster. Simpler. Better. Now. All you have to do is visit one Web site:

www.macworld.com/getinfo

Then select the products, product categories or advertisers for whom you want to receive information. That's it. You can have the information delivered to you by e-mail, postal mail or even telephone. Or you can click on a link that will take you to the vendor's Web site in one easy step.

It's quick. Convenient. Fast. So next time you're interested in a product, don't get a stamp. Get Info.

Macworld

VST Zip 100

BETTER-THAN-DESKTOP PERFORMANCE

POWERBOOK FANS HAVE LONG agreed that a Zip drive would be a natural occupant for their portable's expansion bay. It would simplify grabbing files from a desktop Mac. It would make backing up a PowerBook simple for the first time. And it would be the perfect solution for travelers who store a hard-disk backup, a presentation, or a Web site on each Zip disk.

After more than a year's delay, the VST Zip 100 drive has finally arrived. One version works with the PowerBook



ARNOLD TOESEL

5300, 190, 3400, and G3 models; a second unit fits the 1400. And fit it does: once you've clicked this sleek, lightweight unit into place, it disappears. The exposed surface is colored and shaped to blend perfectly, and even the disk slot is hidden by a spring-loaded dust door.

This drive works exactly like desktop Zip drives, right down to the status lights and the pinhole for popping out a stuck disk (or for ejecting a disk when the PowerBook is powered off). In fact, the VST Zip is *faster* than a desktop Zip drive, although not as fast as the new Zip Plus drives. And this drive ejects a Zip much more gently than the desktop version, the better to avoid knocking the soda off your airplane tray table.

The VST drive is hot-swappable, too: when there's no disk in the drive, you can pop the drive out and replace it with your floppy drive without even putting your laptop to sleep. (The Read Me file suggests shutting down the PowerBook 1400 before swapping and that Apple is working on a fix.)

The Zip starter disk contains the usual software: a backup program, a preferences control panel, and a special Zip extension (the VST drive doesn't work with the standard Iomega extension). This starter disk even includes a Mac OS 8 System Folder—and instructions for starting up from it if your hard drive croaks. For the traveler who can't risk a hard-drive failure on the road, that thoughtful gesture turns this Zip into a security blanket right out of the box.

Just as portable computers cost more than desktop models, the portable Zip costs about \$150 more than a regular Zip. Consider the alternative: packing an external Zip drive, its big black power adapter, and a PowerBook SCSI adapter—and having to shut down every time you want to swap the drive.

Macworld's Buying Advice

If you can handle the price, the VST Zip 100's speed, clean design, and convenience amply fulfill the PowerBook expansion bay's promise. PowerBook users have nothing to lose but their jam-packed briefcases.—DAVID POGUE

RATING: ★★★★★ **PROS:** Sleek and well designed; hot-swappable; faster than standard desktop Zip drive; includes Mac OS 8 startup disk. **CONS:** Not cheap. **COMPANY:** VST Technologies (508/263-9700, www.vsttech.com). **LIST PRICE:** \$350.

Macworld
LAB TEST

VST Zip 100: Faster Than Desktop Model

■ Best result in test. Shorter bars are better. Times are in seconds.

► New product.

	FileMaker Search/Sort	Open Photoshop File	Copy to Drive	Copy from Drive
Iomega Zip Plus	93.1	58.0	18.7	17.3
► VST Zip 100	101.9	50.7	21.6	18.8
Iomega Zip	139.3	49.9	22.4	21.7

Behind Our Tests

For information on our test suite, see "Zip Plus," *Reviews*, February 1998, or www.macworld.com/tests/—Macworld Lab testing supervised by Gil Loyola

Nothing Lasts Longer

The world's
best-selling UPSs
now start at \$99



Renewable
UPS System
DESIGNED
TO LAST A
LIFETIME!

• User-Resettable Circuit Breaker •
• User-Replaceable Batteries •

Full Time Surge Protection

Site Wiring Fault Indicator
automatically identifies building
wiring problems

BlockSafe™ outlets give you room to plug in
transformer blocks

Now the world's best-selling desktop
UPS units offer you even more value
for your power protection dollar! With
over 45% of all data loss and downtime
caused by bad power, your APC invest-
ment pays for itself the first time you use it.

**New: More power and guaranteed
"Best in Class" Longest Runtime.**

Our runtime will meet or exceed that of any
same VA UPS for desktop applications, or
your money back!

Multipath protection for your whole system

APC protects your CPU, monitor, external
modem, laser printer, fax machine, and zip
drives, and provides telephone/network surge
suppression.

User-renewable UPS system

APC QuickSwap™ battery packs are the
quickest and easiest way to safely renew a
UPS, unlike "disposable" UPSs which don't
allow safe user replacement and mean the
end of your investment.

APC products are available at: **MacMall**
1-800-328-2790



APC Back-UPS Pro®,
Back-UPS® and Back-UPS Office® will provide run-
time which meets or exceeds that of any same VA
UPS for desktop PC applications or your money back.
For more information, visit www.apcc.com

Safe, even from lightning

APC multi-stage surge suppression clamps
down on lightning and offers a \$25,000 guar-
antee against damage to your equipment.

APC packs the power and features desktop
users want, plus the peace of mind and
legendary reliability reflected by over
8,000,000 field-tested and proven units.



"Best Uninterruptible Power Supply" "With
its wealth of features..., APC Back-UPS
Pro makes it easy to protect your equip-
ment and data against electrical surges,
brownouts, and blackouts."

MacWAREHOUSE
1-800-255-6227

Back-UPS Pro® Power User Feature

Automatic Voltage Regulation (AVR) and
CellGuard™ intelligent battery management
extend battery life, speed recharging and let
you work through prolonged brownouts
without wasting battery power

APC Safety, Readiness and Reliability

Microprocessor-controlled automatic battery
self-test regularly checks status of the unit
and ensures battery readiness

QuickSwap™ user-replaceable battery
system lets you easily renew the UPS system
and avoid factory service delays

Push-button circuit breaker provides user-
resettable overload protection and eliminates
the need to replace a traditional fuse or even
the entire "disposable" UPS

Internet and network ready



"Editors' Pick: "We wouldn't
be caught dead without an
uninterruptible power supply -
and neither should you."

**FREE! Catalog and UPS
Selection Guide**

Just mail or fax this completed coupon
for your FREE catalog and UPS selection
Guide. Better yet, order them today at:

promo.apcc.com

KEY CODE B576Z

YES! I'd like more information. Please send my
FREE catalog and UPS selection Guide.
 NO, I'm not interested at this time, but please
add me to your quarterly newsletter mailing list.

Name: _____

Title: _____ Company: _____

Address: _____

City/Town: _____

State: _____ Zip: _____ Country _____

Phone: _____

Brand of UPS used? _____ # _____

of Macs on site? _____ # _____

Brand of Servers used? _____ # _____



(888) 289-APCC x8321 • FAX: (401) 788-2797

©1998 APC. All Trademarks are the property of their owners. BK4B7EF - US

(800)347-FAXX PowerFax

E-mail: apcinfo@apcc.com

132 Fairgrounds Road, West Kingston, RI 02892 USA

APC has won more awards for reliability
than all other UPS vendors combined.



Circle 72 on reader service card

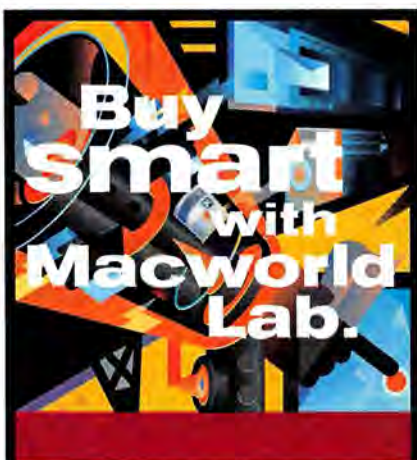

Macworld
LAB TEST

To buy smart when you're choosing Mac OS hardware or software, you've got to put it to the test. Macworld Lab is on the job, testing, scrutinizing, and evaluating the performance and quality of the products you need. With real-world testing, we measure performance by real-life standards. Using the system and applications you'd use to complete the tasks you're faced with every day, our experts come up with answers that matter to you. You can rely on Macworld Lab Test results — We test the products the way you use them.

Macworld
THE ESSENTIAL MACINTOSH® RESOURCE

PhotoTools 2.0

UTILITARIAN PHOTOSHOP PLUG-INS

AIMED AT LESS EXPERIENCED users of Adobe Photoshop, Extensis PhotoTools 2.0 helps you create a variety of special effects. Photoshop pros may decide that many of the effects are just as easy to create without a separate plug-in, but more-mainstream users should find at least a few of the filters useful in day-to-day production work.

PhotoTools 2.0 lets you access its filters not only via a new menu it adds to Photoshop but also through the customizable PhotoBars it places in Photoshop's tool palettes. These iconic commands can trigger any Photoshop menu



PhotoText Makes the Grade PhotoTools' text plug-in lets you set type with professional-style options and preview image layers from within the plug-in.

command, open files within Photoshop, open specific folders in the Finder, and bring the Finder to the foreground. Given that Adobe replaced the Commands palette with the less straightforward Actions palette in version 4.0, advanced Photoshop users will find PhotoBars a welcome addition.

New to PhotoTools 2.0 are the PhotoButton and PhotoCastShadow filters, which automate the creation of 3-D buttons and skewed drop shadows, respectively. If you're creating 3-D buttons for multimedia and Web pages, you should appreciate PhotoButton; it lets you customize the beveling, shading, lighting, and highlighting automatically added to PhotoTools' 16 basic shapes (though you can't import custom shapes). And the new PhotoCastShadow creates drop shadows to which you can apply distortion or additional perspective blur.

The PhotoText filter's text-handling capabilities were the reason to own

PhotoTools 1.0; version 2.0 adds some welcome enhancements, such as basic style sheets and the ability to save entered text to disk. Surprisingly absent are super- and subscripting, as well as support for importing text files from external sources (you can open only text that's saved from within PhotoText, although you can paste Clipboard text into the text-entry area).

The PhotoEmboss and PhotoGlow modules are unchanged from version 1.0 and are reasonably good for anyone confused by Photoshop's advanced layering capabilities. Novices will enjoy the interactive aspect of the PhotoEmboss filter, which offers flexible cutout and dimensional control over a layer. The PhotoGlow filter, also designed for novice users, does an acceptable job; less uniformity around the edges of the glowing object would yield a much more realistic glow, however.

All the PhotoTools plug-ins offer the added benefit of real-time updates, unlimited undos within the actual filter environment, and a clean interface that doesn't hinder productivity (a problem with some other third-party plug-ins). You can preview multiple layers within any of the modules, an incredibly useful feature under real-world production conditions and one that's unique to PhotoTools. The new version does away with the annoying Photoshop Tip of the Day that older versions displayed when Photoshop launched; also missing is the stripped-down version of Extensis Intelligence, a scanning-optimization utility that was included in version 1.0.

Macworld's Buying Advice

PhotoTools 2.0 is a balanced set of practical, if not perfect, additions to any Photoshop artist's toolbox. While not as flashy as other Photoshop plug-ins, such as Alien Skin's Eye Candy and MetaCreations' Kai's Power Tools, it's eminently more useful than most.—DAVID BIEDNY

RATING: ★★★ **PROS:** Brings much-needed text-handling capabilities to Photoshop; quick and easy creation of drop shadows and 3-D buttons; can preview multiple layers; enhances usefulness of Photoshop's interface. **CONS:** Text tool lacks super- and subscripting and can't import text from word-processing programs. **COMPANY:** Extensis (503/274-2020, www.extensis.com). **COMPANY'S ESTIMATED PRICE:** \$129.95.

It's A Big World Out There. Better Get A Big Scanner.



STEP UP TO  MICROTEK

Big news from Microtek. Introducing the *ScanMaker*® 6400XL and the *ScanMaker*® 9600XL large format color flatbed scanners. Both scanners feature 36-bit input and output capability for capturing oversized originals (at up to 12" x 17") in rich, sharp detail and amazingly accurate color.

Now you can scan an entire magazine spread and descreen it with Microtek's award-winning *ScanWizard*™ scanning software in one single-pass — without stitching the image together.

And both scanners are ideal for batch scanning smaller images, too. Simply place your images on the scanning bed and use *ScanWizard* to add as many scan jobs in as you need, even at different settings, resolutions or with different filters applied.

Both of these scanners are available for Windows or Macintosh platforms and include fantastic software like *MetaCreations*™ *Painter*™ 5, color calibration software and much more!



MICROTEK
ScanMaker
9600XL



MICROTEK
ScanMaker
6400XL

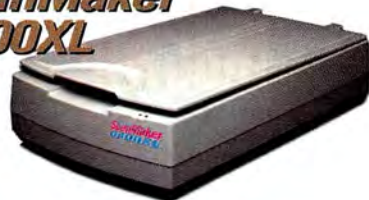

MICROTEK

www.microtekusa.com
1 - 8 0 0 - 6 5 4 - 4 1 6 0

Software-Updating Services

INTERNET-BASED UTILITIES BATTLE OUTDATED SOFTWARE

EVEN IF YOU USE ONLY ONE MACintosh, keeping your applications up-to-date can be a challenge. Throw in the usual mix of control panels, extensions, plug-ins, and other components, and it's enough to make a seasoned computer veteran cry for help. Insider Updates and Shaman Update Server Personal Edition make the job bearable by finding and retrieving updates for you automatically.

Unlike Shaman Update Server, which is designed for networked computers (see *Reviews*, October 1997), Insider Updates 2.01 and Shaman Update Server Personal Edition 1.2 work only on stand-alone

Macs. Besides correcting a bug that prevented the program from functioning behind proxy-based firewalls, the new version is compatible with both PowerPC and 680X0 Macs; the Shaman product works only with PowerPC Macs.

Shaman's interface is more elaborate than Insider's, although I found it a bit confusing in places and the animated splash screen to be quite annoying. On the plus side, Shaman offers significantly more useful information about updates than does Insider (see "Update Info"). On my Mac, Shaman also came out ahead on accuracy: although each program listed some updaters that the other missed, Shaman identified more out-of-date software than did Insider Updates.

It's important to keep in mind that both services are designed to deliver updates—which commercial vendors usually offer at no charge on their Web sites—as opposed to *upgrades*, which typically incorporate significant improvements and come at a price.

Macworld's Buying Advice

Virtually all the updates in Shaman's and Insider's databases are already available elsewhere; only you can decide if the added convenience and peace of mind are worth it. If you spend as little as 15 minutes a week seeking out updates for your software, paying \$6 or \$7 a month may make sense.—FRANKLIN TESSLER

Insider Updates 2.01

RATING: ★★★ **PROS:** Simple interface; small memory requirement; compatible with 680X0 Macs. **CONS:** Doesn't provide detailed information about available updates. **COMPANY:** Insider Software (760/804-9900, www.theinside.com). **LIST PRICE:** \$80 per year.

Shaman Update Server Personal Edition 1.2

RATING: ★★★½ **PROS:** Comprehensive update database. **CONS:** Confusing interface; large memory requirement. **COMPANY:** Shaman (415/241-9952, www.shaman-update.com). **LIST PRICE:** \$69 per year.

Buy
Smart
With
Editors'
Choice.

Macworld
EDITORS'
CHOICE

To buy smart when choosing Macintosh hardware or software, you need an expert's opinion. Fortunately, the experts at Macworld are more than willing to give you theirs. Just leaf through the pages of this issue—or any issue of Macworld. Wherever you see Editors' Choice, you can be sure the product has passed the most rigorous tests for performance and quality in its class. And comes out a winner.

Our reviewers scrutinize just about every Mac product that hits the market. If it wins us over, you can't go wrong.

Macworld
THE ESSENTIAL MACINTOSH® RESOURCE

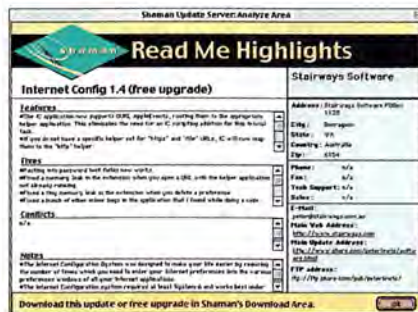

Update Info Where Insider Updates shows you only the version number and size of the available updaters, Shaman Update Server offers more information about each updater so you can decide if it's worth downloading.

Macs. You specify which local volumes you want checked, and the application scans your drives, comparing your software inventory against an Internet database. You select the updates you need, and the program downloads the updaters from Shaman's or Insider's private server or directly from the vendor.

To use either updating service, you need at least a 28.8-Kbps connection to the Internet. The Shaman CD includes more than 600MB of updates, so you'll probably save some downloading time until those updates become outdated. To get Insider Updates, you download the application and purchase an access code from Insider's Web site.

If you prefer the no-frills approach, you'll appreciate Insider Updates' simple interface. Insider is also easier on RAM, requiring a mere 1,121K of memory compared with Shaman's whopping 11MB.

INTERNET CONFUSION

isp
email server \$2,500
modem
router \$1,000
firewall \$2,500
web server \$2,500
internet server
pc
isp?
hub
pc
pc
email server

installation \$3,000
web site creation \$2,000

-OR-

INTERJET

THE ALL-IN-ONE
INTERNET SOLUTION.



Router • Email Server • Firewall • Web Server •

• Intranet • Web Publishing • Easy Administration

The Internet fog has finally lifted. The InterJet™ from Whistle Communications™ is a revolutionary hardware and software solution created for small offices. Capable of handling speeds of 33.6 through T1, it's everything you need to give email and Internet access to the people who need it. Whether it's 5, 10, 50, even 100 employees. And it starts for as little as \$1,995. Find out why the InterJet keeps racking up awards, including the prestigious PC Computing 1997 Networking Product of the Year.

Call 1-888-4WHISTLE. Or visit www.whistle.com/98e.



www.whistle.com/98e

Call 1-888-4WHISTLE

©1998 Whistle Communications. All rights reserved. Whistle, InterJet, Whistle Communications and the Whistle logo are trademarks of Whistle Communications Corp. All other trademarks and registered trademarks are the property of their respective owners.

Circle 84 on reader service card

Puffin Designs Commotion 1.1

ROTOSCOPING POWERHOUSE

THE RELEASE OF COMMOTION 1.0 marked a critical moment in Macintosh software history: no longer were expensive hardware solutions necessary to create special effects and moving-image enhancement (see *Reviews*, January 1998). And not only is Commotion the first truly mature, robust rotoscoping environment for the Macintosh, but it has also become a compelling reason for video professionals to continue to use the Mac for serious production work.

For the first time, uncompressed film and video frames can be played back in real time on a Macintosh, with a frame rate limited only by the amount of available RAM. It's important to use Commotion with a video board that has decent acceleration. We tested the program on a Power Mac 9600 with a Newer Technology 250MHz G3 processor board and an iXMicro Twin-Turbo 8MB video board, which provided real-time 30-frames-per-second playback of a 640-by-480-pixel clip.

Commotion 1.1's new features include support for field and frame painting; "natural" RotoSpline vector shapes; RotoSpline



Animated Splines Commotion's RotoSplines allow precise masking and enhancement of natural moving shapes in an action sequence.

motion blur; more file formats, such as Adobe file-format plug-ins; an improved Super Clone Brush; and enhanced automatic dirt removal.

In Commotion, you can paint on frames directly without immediately rendering the strokes. In fact, you can paint on interlaced video frames and address both sets of video fields without worrying about which field set (even or odd) is dominant—

both sets of fields will register the final rendered paint strokes. And when you save the new frames, the paint strokes are automatically resolved.

Other cool improvements in Commotion's latest version include easier keyboard shortcuts and an automated dirt filter that scans for and removes dirt and dust specks.

Puffin Designs has also introduced a player-only version of Commotion that doesn't include hardware-key protection, for \$399, which will appeal to the lower end of the videophile market.

Macworld's Buying Advice Artists who regularly work in both Adobe After Effects and Premiere agree that Commotion is the missing link in the Mac-based film- and video-effects market. Improving on version 1.0's impressive capabilities, Commotion 1.1 is a strong incremental upgrade to a unique and powerful Mac-based tool.

—DAVID BIEDNY AND NATHAN MOODY

RATING: ★★★★★ **PROS:** Speedy video playback; professional-quality rotoscoping tools; robust masking and compositing support. **CONS:** Hefty RAM requirements; hardware-key copy protection. **COMPANY:** Puffin Designs (415/331-4560, www.puffindesigns.com). **LIST PRICE:** \$2,495.

NetCloak 2.5

COUNTERS, COOKIES, AND MORE

ONE OF THE MOST POPULAR add-ons for Mac-based Web-server software, Maxum Development's NetCloak 2.5 bundles essential server-software enhancements ranging from page counters to conditional commands that deliver different content depending on the date and time. It's the single most versatile server add-on you can buy.

Although the latest version sports dozens of new features and commands, it still relies on easy-to-use, HTML-like commands that you add to your pages. When one of your pages is visited, the application scans the page; processes any NetCloak commands it finds; and passes the results, along with the page's HTML, to your Web-server software. NetCloak commands automate common chores, such as displaying page counters, inserting the time and date, displaying a randomly chosen graphic each time a page is loaded, showing or hiding HTML depending on a user's browser or domain address, and redirecting a user's browser to a different page depending on certain conditions.

The new version's improvements fall

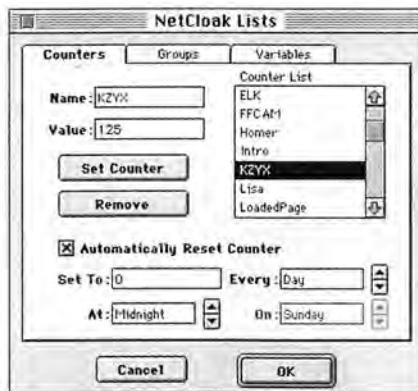

Count on It NetCloak 2.5's enhanced administration features make it easy to examine and reset counters. Here, a counter is configured to reset every day.

into two broad categories: server-software compatibility and command enhancements. On the compatibility front, NetCloak now works with virtually all Mac OS-based server software and supports the new PIXO standard for server plug-ins. As for command enhancements, NetCloak 2.5 adds support for HTTP cookies; several new commands create cookies and manipulate their values, letting you track visitors' progress through your site and display information based on the pages they've already seen. It also offers better support for variables, which among

other things let you store and process information entered into forms.

A new page-counter option lets you specify that one or more counters be reset to zero at specific intervals (such as at the beginning of each day), while other new commands insert those reset dates in a page. Enhanced administration features make it easy to work with counters and variables.

Using NetCloak's more advanced commands can be tricky. Fortunately, the manual is greatly improved: it's much larger and offers numerous examples, a detailed table of contents, and an index. The NetCloak disk includes plenty of examples that you can dissect.

Macworld's Buying Advice NetCloak 2.5 continues Maxum's tradition of providing reliable, well-designed enhancements for Mac OS-based Web-server software. If you want to make your Mac-served Web site more dynamic, put NetCloak at the top of your shopping list.—JIM HEID

RATING: ★★★★ **PROS:** Enhanced command set; excellent support for cookies and variables; improved documentation. **CONS:** More-advanced commands can be tricky. **COMPANY:** Maxum Development (630/830-1113, www.maxum.com). **LIST PRICE:** \$195.

NOW THAT YOU HAVE A VIRTUAL OFFICE, YOU NEED A VIRTUAL BRIEFCASE TO GO WITH IT.



© 1998 Omega Corporation. Omega, the Omega logo, and Zip are registered trademarks, and ZIP BUILT-IN logo, "Because It's Your Stuff," and "The Capacity To Do More" are trademarks of Omega Corporation. Use only genuine Zip disks featuring this symbol  in your Zip drive. *Prices listed are estimated street prices. Actual prices may vary. See PC makers for ZIP BUILT-IN prices.



Make sure your desktop or notebook PC has ZIP BUILT-IN.™ External Zip drive also available for \$149.95 and 100MB disks as low as \$12.95.*

What's the point of having a lightweight laptop if you need a forklift to carry your briefcase? Try toting around genuine 100MB Zip® disks instead. Each one puts the capacity of 70 floppies in the palm of your hand. Like a little virtual briefcase for all your stuff. With over 10 million out there, you'll find Zip drives just about everywhere you go. In fact, most leading PC companies now offer ZIP BUILT-IN™ drives. And if you already have a computer, you can buy an external Zip drive. So pack up your Zip disks and hit the road, warriors. Who needs an office anyway? Get your Zip drive and Zip disks where you get computer products. Or visit our Website: www.iomega.com/zip

BECAUSE IT'S YOUR STUFF.™



PowerPrint 4.0

FASTER ACCESS TO PC PRINTERS

LIKE IT OR NOT, PC PRINTERS ARE in the majority in schools, offices, and homes. For cost-conscious people and organizations, a few-years-old PC printer would make a great partner with older systems . . . except they don't work with Macs. Likewise, many special-purpose printers (including wide-format, continuous-feed, multifunction, and label printers) have no Mac-friendly equivalents.

PowerPrint, a software-and-cable combination from Infowave Imaging (formerly GDT Softworks), lets you use any of several hundred PC printers with your Mac. The software portion consists of a set of drivers; you simply install the appropriate files for the device that's hooked up to your Mac. (To view a list of supported PC printers before you buy, check out the PowerPrint site, at www.infowave.net.)

Compared with previous versions, color reproduction tended to be a little more faithful: colors are more saturated in version 4.0 than they were in version 3.0. More important for day-to-day use, the new version is significantly faster: it performed more than twice as fast in informal tests as



ARNOLD TORRES

version 3.0.2. On an Epson Stylus Color 800, PowerPrint 3.02 took 561 seconds to print a full-page color photo, compared with 243 seconds in PowerPrint 4.0. On a PC, though, the same photo took just 52 seconds to print, while a printer connected to a Mac directly via a serial cable—rather than using PowerPrint—took 49 seconds to image our test file. (For testing purposes, we chose a printer that had both a PC and a Mac connection; you don't need PowerPrint if your printer offers Mac connectivity.)

The increased speed in this version comes from improved drivers and a new serial-to-parallel cable adapter, the key to PowerPrint's ability to connect your Mac to a PC printer's parallel port. In addition to accelerating print times, the new cable is

slightly longer than the old one: 7 feet versus 6. It now requires an ADB port as its power source, which is no problem for desktop Macs and full-size PowerBooks, thanks to a pass-through connector. (For the ADB-less PowerBook Duo series, Infowave offers a special version of the cable.)

Macworld's Buying Advice PowerPrint is significantly improved in version 4.0. Its ease of installation and use hasn't changed—there wasn't anything to improve—but the dramatically faster speed and longer cable are welcome enhancements. For \$100, you can make a useless PC printer useful again. (And if you're on a network of multiple Mac users who need to share a PC printer, Infowave also offers a \$200 PowerPrint Pro version.)

Sure, new color ink-jet prices start as low as \$200—a better deal for most folks than reviving an older PC model—but many special-purpose PC printers don't have Mac equivalents. For these, PowerPrint is a necessity.—GALEN GRUMAN

RATING: ★★★★★/2 **PROS:** Easy to install and use; improved print times; longer cable. **CONS:** Noticeably slower than printing from a PC. **COMPANY:** Infowave Imaging (604/291-9121, www.infowave.net). **LIST PRICE:** \$100.

ClockWork

NEW PIM SHOWS PROMISE BUT IS ALREADY BEHIND THE TIMES

AT A TIME WHEN MOST DEVELOPERS seem to be frantically revving up their Windows versions, it's refreshing to find Mac-only products that really exploit Mac OS technologies. A case in point is ClockWork 1.0, the new calendar program from Century Software. As a new entry in a mature market, ClockWork shines in ease of use and does a fair, although unspectacular, job of handling events and to-do's.

Available only via download from Century's Web site, ClockWork is a breeze to set up and offers hassle-free importing of data files from other calendar programs. It presents a very Mac-like interface, and Undo works from anywhere in the program (a concept more developers should embrace). You create events and to-do's from the same dialog box. Month, week, day, and list views are available; a bar on the left side of the screen shows the current, previous, and following months. You can set alarms for any item, and your PowerBook (and most PowerMacs) can be set to power on automatically when an alarm goes off.



Looking Forward, Looking Back ClockWork gives you a useful scrollable bar that lets you view previous and future months while still viewing the current month in detail.

Unlike competing programs such as Now Up-to-Date and Claris Organizer, ClockWork lacks memo items, a data-entry tool that appears as a menu item in the Finder, and banners for multiday events. You can assign events and to-do's to only one of eight customizable categories (such as Meeting or Travel), and to-do's lack a priority setting, limiting the program's utility as a personal organizer.

ClockWork offers good bidirectional file synchronization between desktop machines and a copy of the calendar file on a PowerBook. It also synchronizes events and to-do's with Newton MessagePads and eMates but not, unfortunately, with the

3Com PalmPilot. ClockWork prints at many standard day-planner sizes, and you can share your calendar file with your workgroup over an AppleTalk network via publish and subscribe; no server is required.

Making good use of other Mac OS technologies, ClockWork is fully scriptable and recordable via AppleScript and offers a handy Scripts menu. You can use MacinTalk to speak your daily appointments, and you can add sound annotations to any item. International users will appreciate that the program displays many countries' holidays and supports WorldScript and Unicode; it can even synchronize Kanji text to a Newton.

Macworld's Buying Advice ClockWork shows promise, but it needs some polishing before it can compete head-to-head with more-mature products. Unless you're an international user or a Newton aficionado, you might want to wait for the next version.—TOM NEGRINO

RATING: ★★★ **PROS:** Easy to set up and use; good PowerBook and Newton synchronization; international support. **CONS:** Lacks some common PIM features; no PalmPilot synchronization. **COMPANY:** Century Software (408/273-6076, www.centsoft.com). **LIST PRICE:** \$49 (single user; multiuser versions available).

HOW DO YOU FOLLOW UP A COOL MULTIMEDIA PRESENTATION?
COOL MULTIMEDIA HANDOUTS.



©1998 Iomega Corporation. Iomega, the Iomega logo, and Zip are registered trademarks, and ZIP BUILT-IN logo, "Because It's Your Stuff," and "The Capacity To Do More" are trademarks of Iomega Corporation. Use only genuine Zip disks featuring this symbol.  in your Zip drive. *Prices listed are estimated street prices. Actual prices may vary. See PC makers for ZIP BUILT-IN prices.



Zip drive. The Capacity To Do More.[®]
Drives for \$149.95 and 100MB disks
for as low as \$12.95.*



Now that your presentations have gone Hollywood, why not let your handouts follow suit. With the capacity of 70 floppies, a genuine 100MB Zip[®] disk can hold your multimedia stuff. Audio stuff. Video stuff. Charts that do the Watusi. With over 10 million out there, you'll find Zip drives just about everywhere you go. In fact, most leading PC companies now offer ZIP BUILT-IN[®] drives. Of course if you already have a computer, you can always buy an external Zip drive. So when the applause dies down, you can either pass out disappointing stacks of paper, or surprise them with copies of the real thing. Get your Zip drive and Zip disks wherever you get your computer products. Or check out our Website: www.iomega.com/zip

BECAUSE IT'S YOUR STUFF.™



Astarte CD-Copy 2.0

UTILITY EASES CD-MASTERING TASKS

WITH THE FALLING PRICES OF CD-R drives and media, more people are making their own CDs. In fact, the glitzy CD-ROM has almost crowded the mundane floppy disk out of its traditional niche, but the larger shiny new disc still isn't quite as easy to use as the venerable plastic square. For those who like to make their own CDs, however, CD-Copy 2.0 makes the task of collecting data easier.

CD-Copy lets you grab files from standard Macintosh or ISO-9660 discs, as well as from audio CDs, and save them to your hard disk, either by saving files from within CD-Copy or by using a straightforward drag-and-drop method. Once you have the files on your hard disk, you can edit them further or accumulate them as you build the contents of a prospective disc.

CD-Copy supports most SCSI CD-ROM drives, as well as numerous ATAPI models, such as those found in recent PowerBooks and low-end desktop Power Macs. During testing, I discovered some incompatibilities with a particular Matsushita CD-ROM drive, but a 2.0.1 update,



Explore Uncharted CDs CD-Copy not only gives a hierarchical view of your data CDs but also provides detailed technical information about the disc.

which fixes this problem, should be available by the time you read this.

In addition to having file and data-retrieval features, CD-Copy can double as a great tool for satisfying your curiosity. Provided that your CD-ROM drive allows it, CD-Copy can display precise statistics and additional information about a CD, including exact start and finish time of sessions on a CD or which software mastered it. Although this sort of information is only nominally useful for most users, it makes for interesting exploration.

In addition to grabbing files, folders, and tracks from CDs, CD-Copy can also duplicate an entire CD session into a single file. But although this feature lets you easi-

ly store a complete partition for later archiving, my testing uncovered a fairly large caveat for copying multiple audio tracks.

I copied three adjacent CD tracks into a single image file with CD-Copy and then used Adaptec's Toast software—originally an Astarte product—to burn CDs on an APS CD-R Pro drive. Unfortunately, the resultant disc didn't contain three tracks but instead a single track containing all three songs. Although this glitch isn't explicitly the fault of CD-Copy, it shows that sometimes even an intuitive user interface isn't enough to give you the result you *think* you'll get.

Macworld's Buying Advice Many of CD-Copy's features are available elsewhere, either as part of Mac OS 8 or within popular CD-R mastering software, albeit not necessarily as well integrated. CD-Copy is one of those tools you either desperately need or don't need at all. Its reasonable price makes it a good value, but this product's not for everyone.—STEPHAN SOMOGYI

RATING: ★★★ **PROS:** Displays interesting details; allows easy duplication of data CDs. **CONS:** Results aren't always what you expect; finicky about drives. **COMPANY:** Astarte (612/483-5338, www.astarte.de). **LIST PRICE:** \$99.

Mac users appreciate easy. And no one makes having a website easier than InterLand®. From as little as \$19.95 a month, you can start a business, promote an existing business or even share your hobby with the world. And we'll be with you every step of the way with toll-free, 24 hour support. We can even help you with professional website design. Whether you're a beginner or a computer veteran, InterLand can help bring you the world.



30 Day
Money Back
Guarantee

HE'S GOT A WEBSITE. DO YOU?

- Website Hosting
- Website Design
- Reseller Programs

**Pricing From
\$19.95 per Month**

- www.anynameyouwant.com
- 80 megabyte storage
- unlimited e-mail forwarding
- unlimited e-mail aliases
- unlimited e-mail autoresponders
- free domain registration*
- front page '97 & '98 support
- real time credit card servers
- unix and nt servers
- anonymous FTP
- real time statistics
- secure server
- RealPlayer
- RealAudio
- Cold Fusion and more

**1-800-599-0547
(404) 586-9999**

The Only Website Hosting Company With 24 Hour Toll-Free Support

*EXCLUDES INTERNET'S \$50 ANNUAL DOMAIN FEE. SAME DAY SET UP ON ALL ORDERS. \$40 ONE TIME SET UP FEE ON NEW WEBSITES.

Circle 10 on reader service card

Now you can use your Mac to its full design potential.

Take the Mac Design Library

A \$124⁹⁹ value



FOR JUST \$5.95

as your introduction to the Mac Professional's Book Club.

You simply agree to buy 3 more books—at significant savings—within the next 2 years.

Now, you can know the secrets to creating stunning graphics and visual effects on your Mac. With the MAC DESIGN LIBRARY, you have access to the resources, strategies and software tools for getting the most out of Photoshop.

FUNDAMENTAL PHOTOSHOP 4:

A Complete Guide, 3rd edition

by Adele Droblas Greenberg & Seth Greenberg

This well-organized, easy-to-follow guide helps you master the basics and the most advanced aspects of Photoshop. Assuming no prior knowledge, you'll learn how to digitize, color correct, retouch images, create color separations and special effects, and more! In no time you'll be able to produce graphics for the Web, multimedia, print, and digital video.

Publisher's Price \$34.99

PHOTOSHOP 4 COMPLETE

by Kate Binder, Ted Alspach, et al.

With emphasis on the high-end Photoshop tools and advanced graphic techniques, this book, with companion CD, teaches you how to maximize the benefits of the channel palette, perform custom colorization, use filters, speed up the program, master digital watermarking, and more. Includes an interactive demo version of Photoshop 4 along with try-out versions of other Adobe special effects products.

Publisher's Price \$45.00

PHOTOSHOP WEB MAGIC 2

by Jeff Foster

This recipe-style book takes you step by step through the procedures for producing special effects for the Web using filters and other Adobe Photoshop tools. Learn how to develop a stunning array of Web page buttons, backgrounds, animations, and menu bars. Companion CD is filled with demo software, splendid textures and patterns, and stock photography images.

Publisher's Price \$45.00

Don't delay! Join the Mac Professional's Book Club today and take the MAC DESIGN LIBRARY for only **\$5.95!**

The Mac Professional's Book Club provides Mac users with the finest titles from a variety of publishers to help you get the most out of your Macintosh system. Keep up-to-date with books and book/disk sets on the latest software releases, programming tools, hardware upgrades, networking, communications, and much more. All books are available to you at significant savings, with prices starting as low as \$10.95

MEMBERSHIP BENEFITS

In addition to getting MAC DESIGN LIBRARY for only \$5.95 when you join, you keep saving substantially with discounts of up to 50% off the publishers' prices on books you choose to purchase. • Also, with your first purchase of one regular selection, you'll earn Bonus Credits you can use to save even more. • When you qualify as a Preferred Member, you'll earn double Bonus Credits and enjoy other special benefits. • Moreover, our books are always identical to the publishers' editions. You'll never receive an "economy edition" with inferior paper and bindings from us. • At 3-4 week intervals (15 times per year), you will receive the Mac Professional's Book Club Announcement, describing the coming Main Selection and Alternate Selections, together with a dated reply card. • In addition, up to three times a year you may receive offers of Special Selections which will be made available to a group of select members. • If you want the Main Selection, do nothing, and it will be sent to you automatically. • If you prefer another selection, or no book at all, simply indicate your choice on the card and return it by the date specified. • You will have at least 10 days to decide. If, because of late mail delivery of the Announcement, you should receive a book you do not want, we guarantee return postage.

Mac Professional's Book Club

PO BOX 6019 DELRAN NJ 08075-9659

Please accept my application for trial membership and send me MAC DESIGN LIBRARY (00740) billing me only \$5.95, plus shipping and handling. I agree to purchase at least three additional selections at regular member's prices over the next 2 years. As a member, I can save up to 50% off the publishers' prices. My membership is cancelable any time after I buy these three additional books. A shipping-and-handling charge is added to all shipments.

No-Risk Guarantee: If I am not satisfied—for any reason—I may return MAC DESIGN LIBRARY within 10 days. My membership will be canceled, and I will owe nothing.

Name _____

Address _____ Apt. _____

City _____

State _____ Zip _____

(Books purchased for professional purposes may be a tax-deductible expense. Prices are slightly higher outside the U.S. and are invoiced in U.S. dollars.)

Mac World 4/98

A-ER9

Circle 47 on reader service card

Ray Gun

CLEAN UP DIRTY AUDIO IN A SNAP

ONE CRITICAL ELEMENT OF sound plagues the audio world more than any other: noise. Air conditioners, electrical ground loops, traffic, the hum of hard drives, computer fans—potential noise sources are as plentiful as they are hard to defeat. Luckily, Arboretum Systems' Ray Gun 1.0, a robust "denoiser" plug-in, comes at a price that puts it within reach of any audio enthusiast.

Named for its "point-and-shoot" operation, Ray Gun eliminates common audio foibles such as hiss, crackling, popping, hum, and broadband noise. The application works in real time, requires a Power Macintosh, and works either in stand-alone mode or as a plug-in to Adobe Premiere or any program that accepts Premiere plug-ins. It also works with the bundled HyperEngine, Arboretum's own plug-in environment.

Ray Gun runs in three modes: noise reduction, pop suppression, and rumble/hum filtering. You can enable each mode individually, depending on the requirements of the audio clip. In noise-reduction mode, Ray Gun analyzes an audio sample; it detects consistent, wide-frequency noise; and it



Zap! Ray Gun (seen here operating in Arboretum's HyperEngine application) puts a simple interface on complex inner mechanics.

attempts to attenuate those frequencies without affecting other frequencies. The pop-suppression mode fixes transient noise, such as crackles, clicks, and pops. Filtering mode gives you control over certain frequencies; the Rumble filter eliminates the low-frequency noise common to vinyl albums, while the 50- and 60-Hz filters reduce electrical hum. Output-level sliders let you make up for any loss in overall volume.

Used carefully, Ray Gun helps bring out the musical and audio detail of fairly mangled recordings. We were able to remove audio hiss that was fully half as loud as the actual harmonic content of a musical

passage, with very little distortion of the music. Spoken-word passages also held up very well. Using the noise-reduction feature requires the most care; certain passages may require some high-frequency equalization to restore some of the original brightness.

Ray Gun may introduce volume "pumping" or a tremolo-like warbling to an audio clip if its parameters are set too high. The sliders are occasionally disabled when the application is used as a plug-in to HyperEngine; reopening or reapplying the effect seems to clear up the problem. The software also lacks printed documentation, though the installer CD-ROM comes with extensive HTML documentation.

Macworld's Buying Advice Ray Gun is inexpensive, operates within a wide variety of host applications, and yields astounding results. If you've been stashing away your outdated vinyl LPs, it's time to haul them out of the closet and blast them with Ray Gun.—NATHAN MOODY AND DAVID BIEDNY

RATING: ★★★★½ **PROS:** Great one-button audio noise reduction; significantly improves processed audio quality; simple interface. **CONS:** Minor bugs; lacks printed documentation. **COMPANY:** Arboretum Systems (415/626-4440, www.arboretum.com). **LIST PRICE:** \$99.

Buy smart with Editors' Choice.

MACWORLD EDITORS' CHOICE

Macworld
EDITORS'
CHOICE

To buy smart when choosing Macintosh hardware or software, you need an expert's opinion. Fortunately, the experts at Macworld are more than willing to give you theirs. Just leaf through the pages of this issue — or any issue of Macworld.

Wherever you see Editors' Choice, you can be sure the product has passed the most rigorous tests for performance and quality in its class. And comes out a winner.

Our reviewers scrutinize just about every Mac product that hits the market. If it wins us over, you can't go wrong.

Macworld
THE ESSENTIAL MACINTOSH® RESOURCE

1997 It's the 10th revision and it's a rush.

It's got to be perfect, but color output costs too much.

What you say about color printing can't be printed here.

1998 You get the Xerox DocuColor 5750. It adds new words to your vocabulary.



Now you can get color on-budget and on-time. Because the Xerox DocuColor 5750 Digital Color Copier/Printer offers high-quality continuous-tone color at an affordable price. In fact, you can get a connected unit for the cost of a stand-alone color copier/printer. At 6 ppm, it prints Pantone-licensed color and sharper black text. And no one offers more certified front



DocuColor 5750

ends (EFI Fiery, DocuPress, Splash). What's more, the DocuColor 5750 is only one member of the Xerox family. The Xerox Regal 5790 is a proven workhorse. And the DocuColor 40 delivers consistent quality color at a breathtaking 40 ppm. All come with our Total Satisfaction Guarantee. Visit our Web site at www.xerox.com. Or call us at 1-800-ASK-XEROX, ext. 670.

THE
DOCUMENT
COMPANY
XEROX

XEROX® The Document Company®, the digital X and the identifying Xerox product names and numbers herein are trademarks of XEROX CORPORATION. EFI Fiery®, Splash, and DocuPress are trademarks of their respective owners. In conjunction with Xerox' efforts to reduce the company's impact on the environment, Xerox equipment includes new, reprocessed, and/or recovered parts and assemblies. 38 USC 380.

Circle 100 on reader service card

Save Your Mac!

BY HENRY BORTMAN

Surefire Strategies to Survive and Thrive in a Windows World

SOONER OR LATER IT'S BOUND TO happen. You can avoid it. You can try to fight it. But eventually, you're gonna have to deal with Windows. Maybe your IS department is threatening to put a PC on your desk because your Mac doesn't conform to the company's network standards, or you're seeing more and more of your customers walk in the door with PC-formatted disks in hand. Whatever your personal Windows nightmare, one fact remains—the best way to ensure that your Mac survives is to learn to coexist. To navigate the cross-platform labyrinth, you need to know what problems to watch out for and how to solve them. That's just what this *Macworld* expert guide will help you do.

SOONER OR LATER IT'S BOUND TO happen. You can avoid it. You can try to fight it. But eventually, you're gonna

Scenario #1: Dealing with a PC Disk

A client just brought you an Iomega Zip cartridge with a bunch of text files and photos. You pop in the cartridge, but after it mounts on your Mac's desktop, all the files have the same generic icon that simply says "PC." They also have unintelligible names like TOTALR~1.DOC and TOTALR~2.DOC. You've got three problems here, one of which Apple has already solved (lucky you).

Mounting a PC Disk This is the part you don't have to worry about. Apple bundles with the Mac OS a control panel called PC Exchange that can mount (recognize and display on the desktop) DOS-formatted disks. If your client's PC disk



© 1994 AMERICA

doesn't mount, check to see that PC Exchange is present in your Control Panels folder and turned on. If you still can't get the disk to mount, check with the person who gave it to you to see how he or she formatted the disk and what operating system he or she is using.

Tell your Windows buddies to give files short names if you're going to shuffle them back and forth

If you're using third-party cross-platform software (for recommendations and ratings, see the feature "Mac Life Preservers," elsewhere in this issue), you may encounter other glitches. For instance, if you use DOS Mounter 95, from Software Architects (\$100; 425/487-0122, www.softarch.com), your Mac may eject PC-formatted Iomega Zip or Jaz cartridges. Here's a tip: Rename the Iomega Driver file in your Extensions folder nIomega Driver. This will make it load *after* DOS Mounter's MultiMounter extension and will clear up the problem.

Some of the newest PC models come with a version of Windows 95 known as OSR2, which offers users an option to format disk volumes larger than 2GB by using a disk format known as FAT32. This new format isn't widely used today, but when Microsoft releases Windows 98 and NT 5.0 (which will also offer FAT32 as a formatting option), it will become more prevalent. The version of PC Exchange that comes with Mac OS 8.0 (version 2.1.1) can deal only with the older FAT16 standard. PC Exchange 2.2, which is bundled with Mac OS 8.1, can recognize FAT32-formatted disks, but you *must* be running Mac OS 8.1 to use it.

Handling Long File Names So what about those weird file names on your client's Windows disk? Unfortunately, that's a sign that Apple's PC Exchange software hasn't caught up with Windows 95 and NT 4.0.

These operating systems support file names up to 253 characters long. But as of Mac OS 8.0, PC Exchange (version 2.1.1) could handle only the older DOS "8.3"-style file names, which can be only as long as 12 characters and typically take the form of 8 characters

followed by a 3-character extension.

For each file on a DOS-formatted disk, Windows 95 and NT 4.0 store both the newer, long file name and a truncated, 8.3 version of that name. PC Exchange 2.1.1 recognizes only the truncated version. This can result in file

names that, at best, are difficult to distinguish from one another and that, at worst, look like complete gibberish.

You've got two choices for dealing with this. The least-expensive solution—if you're already running Mac OS 8—is to upgrade to 8.1. (The 8.1 updater is available free from Macworld

Online, www.macworld.com/more/.) This new version of the Mac OS ships with PC Exchange 2.2, which is savvy to Windows' long file names and properly displays Windows file names up to 31 characters long.

Did someone say 31 characters? What happened to 253? Sorry. Even though Windows 95 and NT 4.0 can support longer file names, the Mac OS 8.1 Finder still supports names only as long as 31 characters. So you might want to tell your Windows buddies to limit their file-name lengths if you're going to shuffle files back and forth.

The other alternative is to purchase DOS Mounter 95 1.1. It can recognize and display Windows' long file names even without requiring you to upgrade to Mac OS 8.1. It, too, is limited by the Mac OS to displaying 31-character file names. The current version of DOS Mounter also doesn't support FAT32-formatted disks, although Software Architects plans to fix this in a forthcoming version.

By the way, neither PC Exchange nor DOS Mounter actually *changes* the names of the files on a DOS-formatted disk; they just display truncated names in the Mac Finder.

Displaying Proper Icons The Mac OS and Windows use different methods to decide what type of icon to display for each file. File extensions are there for a good reason—they're how Windows knows what each file's internal data format is and which application to open it with when you double-click on it. A file whose name ends in .DOC, for example, is a Microsoft Word document.

The Mac OS uses a different scheme. It assigns two invisible four-character "labels" to each file, known as the file's *type* and *creator*. Unfortunately, your Mac doesn't know how to

Across the Great Extension Divide

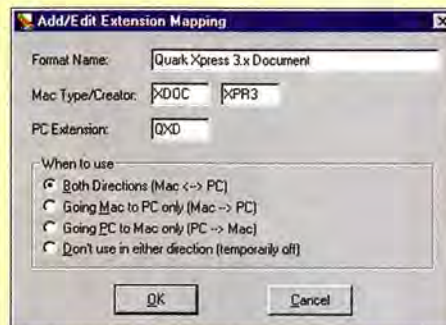
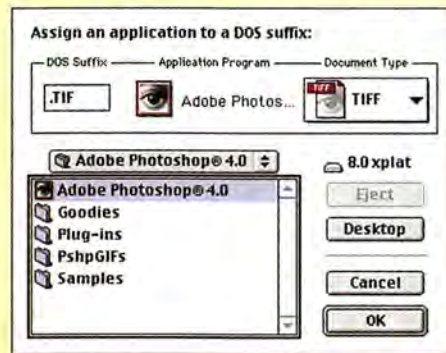

WINDOWS PCS AND MACS RECOGNIZE FILES IN different ways. PCs look for *extensions* tacked onto file names—such as .tif if the file is a TIFF image—and Macs look for invisible type and creator labels. To successfully share files, you need to let the different platforms know what's what. You can solve this problem of *extension mapping* on the Mac side with Apple's PC Exchange (top) and on the Windows side with DataViz's MacOpener (bottom).

Unruly Icons

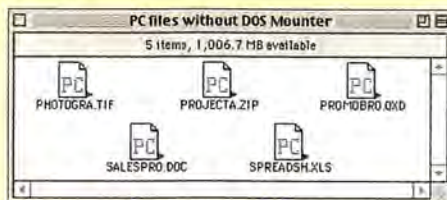

ANOTHER PROBLEM YOU'LL FACE IF YOU don't deal with extension mapping is generic file icons (top) that you can't double-click on to open. Without help, Mac OS 8's built-in software, PC Exchange 2.1.1, can't display proper icons or the long file names of Windows-based files. You can fix these problems by installing Software Architect's DOS Mounter 95 (bottom) or by upgrading to Mac OS 8.1.

interpret Windows file extensions without help. Hence the funky icons. The solution is to build an *extension map* on the Mac that associates the proper Mac file types and creators with their Windows file-extension equivalents.

PC Exchange and DOS Mounter 95 can both help you with extension mapping, but whichever product you choose, you'll probably have to do some work yourself. PC Exchange comes with a pathetic built-in extension map that simply maps .txt files to SimpleText ASCII text files. This means you'll have to manually enter all the mappings you need to deal with—at least the first time. Once you've built your extension map, PC Exchange creates a preferences file containing all that data. By copying this file from one Mac to another, you can duplicate your extension map with minimal effort.

DOS Mounter 95 has the opposite problem. It comes with a fairly comprehensive built-in extension map. The big drag is that if you do have to update it, you'll have to do so separately on each Mac in your operation.

Extension-Mapping Aids Many shareware utilities can also help you deal with extension mapping and other cross-platform-compatibility issues. All of them are available from Macworld Online.

Macworld has created an exclusive PC Exchange preferences file that con-

they'll behave properly on Windows. Daniel Azuma's FileTyper (\$10; www.ugcs.caltech.edu/~dazuma/filetyper/index.html) gives you a quick and easy way to examine or set the type and creator for individual files.

Mounting Removables So, by now you've managed to deal with the file-naming and extension-mapping issues successfully. You've opened your client's Word and TIFF files, and you've created

Out of the box, Windows 95 and NT can't even mount a Mac-formatted disk

tains extension mappings for many of the market's most popular productivity and graphics applications. Ilan Szekeley's Type/Creator Database 2.9 (\$10; www.geocities.com/SiliconValley/Bay/5677/) also provides an exhaustive database of extension mappings.

Another utility, Cross Platform, from Sig Software (\$25; www.sigsoftware.com), can help you analyze your Mac files and tell you which Windows application (and, if necessary, which file-format-translation filter) is required to read it on a PC. NameCleaner (\$20), also from Sig Software, helps you check and fix your Mac file names so that

her brochure. It's too big to fit on the client's overstuffed Zip cartridge, but that's no big deal. You can just put it on a spare Mac-formatted one. Right?

Actually, if you mount a Mac-formatted disk (other than a floppy), you'll find that DOS formatting isn't an option. What gives? Alas, PC Exchange will *reformat* removable disks with DOS formatting only if they're *already* DOS-formatted. If they're Mac-formatted, you're stuck. The new PC Exchange 2.2 won't fix this either.

There are several workarounds. The first is to buy some spare removable cartridges preformatted for DOS. If you

use Zip or Jaz cartridges, you can download the free Iomega Tools 6.0 from Iomega's Web site (www.iomega.com). Unlike previous versions of this utility, Iomega Tools 6.0 lets you reformat Mac-formatted Zip and Jaz cartridges for DOS from your Mac. At press time, the 6.0 version was in beta.

If you have DOS Mounter 95, you've got another option. DOS Mounter 95 comes bundled with a stand-alone utility called MultiFormatter, which can reformat a Mac-formatted disk for DOS. (A handy plus is that it also lets you create Mac and DOS partitions on the same disk.)

If you use SyQuest cartridges, the drill is slightly different. Remove your cartridge, and restart your Mac with extensions off (by holding down the shift key at start-up). Reinsert the cartridge, and launch SyQuest's MacUtil utility (available from the company's Web site, at www.syquest.com). Click on the Quick Erase button. This will remove Mac formatting from your cartridge. When you restart your Mac with extensions on, you should be able to format the cartridge for DOS.

Scenario #2: Mac Disks on a PC

If you're the only Mac designer your client has to deal with, she might reasonably expect her DOS-formatted disks to be the standard. But if she exchanges files with several Mac users, she might be better off taking care of the problem herself.

The problem is that out of the box, Windows 95 and NT 4.0 can't even *mount* a Mac-formatted disk. Without the addition of third-party software, all Windows PC users get when they put your Mac-formatted cartridge into a PC is a warning that the disk is "not formatted" and an invitation to erase it.

Mounting Mac Disks on a PC

There are several utilities that *do* let a PC user mount Mac disks on a PC (see

the feature "Mac Life Preservers," elsewhere in this issue). Our favorite is MacOpener 3.0, from DataViz (\$59; 203/628-0030, www.dataviz.com). It's pretty straightforward: You install it, it works. It lets Mac disks show up in Windows' My Computer window just like DOS disks. MacOpener also lets PC users

save and name their files. That way, when the files show up on the Windows side, they will be handled properly.

MacOpener offers another solution to this problem. Like other cross-platform file-management utilities, it too contains an extension-mapping table. This feature has an option that, based on

trudges back and forth between the two platforms. But if your computers are networked, an additional set of file-sharing options is available to you.

Using a network to share files cross-platform has an added benefit: it lets Macs access printers connected to Windows PCs and Windows networks and lets Windows PCs access printers connected to Macs and Mac networks.

By transferring files cross-platform over a network, you avoid many of the problems associated with disk swapping but you encounter a whole new set of challenges. You see, just as Macs and Windows PCs deal with disks, file names, and icons differently, they also use different schemes for file sharing.

Your First NT Server One of the advantages that Mac users have long claimed for their platform is the ease with which they can share files and printers over a network. Apple has long offered easy-to-maintain AppleShare servers, dedicated Macs running special software that allow small workgroups of Mac users to share files without requiring the expert services of a network manager. In System 7, Apple also built in *peer-to-peer* file sharing, which lets Mac users exchange files directly with one another over a network without having to set up and access a dedicated AppleShare server.

By transferring files over a network, you'll avoid most disk-swapping problems but face new challenges

reformat DOS-formatted disks for the Mac, including removable cartridges. MacOpener not only solves the Mac-disk-mounting problem but helps you deal with file naming and extension mapping as well.

Mac File Names Since Windows 95 and NT 4.0 support longer file names than the Mac OS does, any old crazy name you give a file on a Mac will behave itself on Windows, right?

Not quite. There are two file-name-related problems that Mac users who want to transfer files to PCs need to solve. The first is that Windows doesn't allow certain characters in file names that the Mac OS does allow. Specifically, backslash (\), slash (/), colon (:), asterisk (*), question mark (?), inch marks ("), less than (<), greater than (>), and bar (|) are forbidden in Windows file names. Nothing disastrous will happen to the PC if a Mac file name does include these characters—MacOpener will just treat the file name as if it contained underscores instead—but it's probably best to avoid them.

Extension Mapping, PC Style The second issue is—you guessed it—file-name extensions. We covered this for the PC-to-Mac case, but it's also important to consider when files are going from a Mac to a PC. Remember, PCs don't know about Mac file types and creators. Windows relies on a file's three-character extension to figure out which application to launch when a user double-clicks on the file. Unfortunately, Mac users don't typically append extensions to their file names.

One obvious way around this is for Macintosh users to train themselves to include file-name extensions when they

a Mac file's type and creator, automatically appends an appropriate extension.

These file-name changes are permanent. When you move the disk on which they reside back to a Mac, the extensions are still there. While this may annoy some Mac users who find the mere notion of consorting with DOS file-name extensions offensive, MacOpener's automatic appending does ensure that files behave themselves on the PC side, which—after all—is the point. (And if you really want to, you can turn this feature off.)

Scenario #3: Mac Network Meets Windows Server

So far we've discussed sharing files between Macs and Windows PCs by shuffling floppies or removable car-

But Mac OS file-sharing performance degrades quickly as the number of users sharing files grows, and even dedicated AppleShare servers don't hold up well if you typically pass around loads and loads of multimegabyte files. For this reason, many Mac users today are looking to Windows NT Server 4.0 as an alternative to AppleShare servers.

NT Services for Macintosh If all you're looking to do is replace your AppleShare server with a higher-performance NT Server, you may be satisfied with NT Server's built-in Services for Macintosh (SFM). NT Server 4.0 comes with AppleShare file-sharing and printer-sharing capabilities

Welcoming Macs to the Windows World

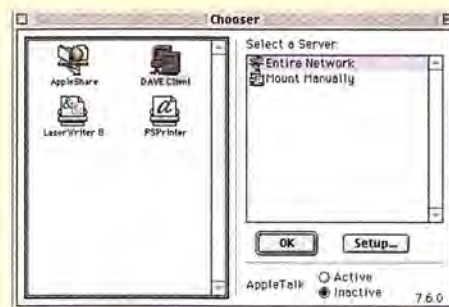

EVEN IF YOU'RE ONE OF THE FEW MAC USERS in a Windows-dominated office, network file sharing doesn't have to be painful. If you're forced to abandon the Mac's built-in AppleTalk networking, Thursby Software Systems' Dave 2.0 can help. By providing a Chooser icon through which you can access shared Windows volumes, Dave makes the experience almost as Mac-like as using AppleShare.

built-in. By activating this option, you enable all the Mac users to access and exchange files that have been designated as shared on the NT Server.

If your entire network consists of an NT Server running Services for Macintosh and a bunch of Mac clients (jargon for computer workstations that access files on servers), you don't have to worry about file names and extension mapping. Even though your files are physically being stored on a Windows PC, the NT Server's SFM software stores file-type and -creator information for Mac files and doesn't require that you append extensions to your file names. From a Mac user's perspective, it's no different than accessing an AppleShare server.

A note of caution: When you first set up your NT Server, you'll be asked to choose between two disk formats—FAT or NTFS. FAT (file allocation table) is the standard DOS format; NTFS (NT file system) is NT's high-performance format. Make sure you pick NTFS for any volumes that you want to share, as FAT-formatted vol-



umes can't be shared. decided that the time has come for the Windows 95 PCs in the sales department to become full citizens on the Mac network. Or maybe your company is buying new computers and just plain wants to save a few bucks—after all, at this point Windows PCs are still usually cheaper than Macintoshes.

However it happens, the time may

Once one Windows PC shows up on your network, others may follow, and not necessarily as servers

umes can't be shared.

Also, although NT Server's Services for Macintosh lets Mac as well as Windows PC clients access its shared files, it doesn't provide any way for Macs and PCs to exchange files directly with each other. In other words, it doesn't offer support to peer-to-peer file sharing across platforms.

Scenario #4: PCs Proliferate but Macs Rule

Once the first Windows PC shows up on your network, others may follow—and not necessarily as servers hidden away in a closet, masquerading as AppleShare servers. Maybe your organization has decided to bring a couple of NT workstations in-house to run specific applications (such as 3-D-rendering apps) that scream on NT but are sluggish on the Mac. Maybe one of the higher-ups in your company has de-

come when you find that your little group of Mac users (who were getting along just fine using Mac OS's built-in peer-to-peer file sharing, thank you) are now supposed to figure out how to include Windows users as well.

Peer-to-Peer File Sharing If Macs are the dominant platform and AppleTalk is the established network but a few PCs want in, you need to find a way to let Windows PC users join in the Mac peer-to-peer file-sharing experience.

We recommend the versatile PC MacLAN, from Miramar Systems (\$199; 805/996-2432, www.miramarsys.com). Miramar sells different versions of the product, one for Windows 95 and another for Windows NT 4.0 (Workstation or Server). When installed, the program enables a PC to participate in Macintosh-style peer-to-peer file sharing over an AppleTalk network.

With PC MacLAN running, Windows PC users can see shared Mac vol-

umes and networked PostScript printers in their Network Neighborhood (the Windows equivalent of the Mac's Chooser). The shared volumes and printers can be accessed just as if they were on a Windows network.

PC MacLAN makes it equally simple for Windows PC users to share a portion of their local disks with Mac users. All they have to do is click on a folder icon with the right mouse button, select the AppleTalk Sharing item from the pop-up menu that appears, and fill in the relevant information about

what to call the shared volume and who has permission to access it. Mac users on the same network can then access this shared folder just as they would folders shared by other Mac users.

File Names and Extension Mapping

As is the case when you move Windows PC and Mac files back and forth on floppies, when you share cross-platform files across the network, you're going to have to deal with file names and extension mapping. Otherwise, files will not appear with correct icons and you won't be able to double-click to open them.

When you use PC MacLAN, you build your extension map on the Windows side of the fence. You can move this information from one Windows PC to another by arcane means—mucking around in the Windows Registry Editor for the Windows 95 product, editing a tab-delimited text file for the NT product, and then uninstalling and reinstalling the PC MacLAN software. But if I were you, I'd stick to the reliable but tedious method: entering your updated extension-mapping information on each Windows PC separately.

Be forewarned that PC MacLAN's extension mapping doesn't help Windows PC users display proper icons for Mac files. For that, Mac users have to get in the habit of appending DOS extensions to their file names.

A Word of Caution PC MacLAN's purpose is simply to extend Mac OS file sharing to Windows 95 and NT 4.0 users, not to function as industrial-strength server software. Take into

account that only ten AppleTalk clients can log on simultaneously to a Windows PC running PC MacLAN.

Although PC MacLAN's NT version will run on either NT Workstation 4.0 or NT Server 4.0, using the Services for Macintosh built into NT Server is a

the Chooser, using the Dave Client icon, which functions much like the AppleShare icon. Or you can use Dave Access, which offers a richer set of connection and file-display options. Whichever method you choose, once you've mounted a shared PC volume,

type the *first* time it opens that kind of file. This means, for instance, that if you open a TIFF file before you build your extension map, TIFF files will forever display with generic icons, even after your map is built and in place.

The long and short of it is that you need to build your PC Exchange extension map first, before you start using Dave. And notice that I said PC Exchange (that's right, the application built into the Mac OS); I did not say DOS Mounter. That's the other little gotcha to be aware of if you use Dave. It can't access DOS Mounter's extension map; it can use *only* PC Exchange's.

From the Windows perspective, extension mapping is a nonissue, as long as Mac users cooperate. Dave doesn't install any software on the PC side, so it's up to the Mac types such as you to religiously append proper DOS extensions to all your file names. If you put the extensions there, Windows 95 and NT 4.0 will handle your files properly. If you don't, there's a chance that PC users will complain—and IS may come gunning for your Mac again.

The Last Word

If you've been running for cover every time you see Windows lurking around the corner, it's time to face the facts. We're living in a cross-platform world. The prevalence of Windows doesn't necessarily mean you have to give up your Mac, but it does mean you're going to have to learn to get along with PCs. The tips we've offered here should provide you with a foundation on which to build a solution right for you.

Just remember: You may have to do a few things here and there the Windows way to keep your clients, or your boss, or the IS department happy, but if it means you still get to see "Welcome to Mac OS" every morning when you turn on your computer, there's still hope. **m**

If you've been running for cover, now's the time to face the facts. We're living in a cross-platform world.

better way to go if your organization has lots of users who all need to access the same shared volume at the same time. Windows NT Workstation users integrating their PCs into Mac networks will find significant value in PC MacLAN, but it's doubtful you'd get much out of installing it on a Windows PC running NT Server.

Scenario #5: Your Mac Fights for Its Life

This one is a Mac-o-phile's worst nightmare. Here's the scene: You work in the graphics department of a large company that's overwhelmingly dominated by Windows PCs. In fact, your little corner of the world is the last holdout for the Mac in the entire operation.

The IS department has been complaining to the top brass for years about wanting to get AppleTalk off the corporate network. As a result, the bean counters in accounting are threatening to get rid of your Macs and replace them with Windows PCs running NT Workstation. You've tried every argument you can think of to stall.

Well here's one more tack you can take. Tell them you want to install Dave 2.0 on your Mac. Dave, from Thursby Software Systems (\$119; 817/478-5070, www.thursby.com), like PC MacLAN, enables peer-to-peer file sharing between Macs and PCs. But instead of doing it with AppleTalk protocols, Dave uses Windows networking protocols. With Dave, not only will you fit in, but all the work is done on *your* end—no software at all is required on your IS department's precious Windows PCs.

Once installed, Dave gives you a couple of different ways to access shared Windows volumes. You can work from

you can make an alias for it and avoid clicking through Dave Client or Dave Access in the future.

To share a folder on your Mac with Windows PC users (or other Mac users also running Dave), you use the Dave Sharing control panel. On your colleagues' Windows 95 or NT 4.0 PCs, your shared volume will show up in the Network Neighborhood alongside the items those PCs share with each other.

Dave does have a lot of little pieces, and if you're not used to Windows networking you can easily get lost. But if you stick to the basics, Dave is as straightforward to use as AppleShare.

When Dave displays the contents of a Windows directory, it uses the PC Exchange preferences file to do its extension mapping. Not surprisingly, there's a twist. Be warned: Dave *permanently* sets the icons it displays for a file

Welcoming Windows to the Mac World



IF YOU NEED TO INTEGRATE A FEW WINDOWS PCs into your established group of networked Macs, Miramar Systems' PC MacLAN will help them fit in and smoothly join in file sharing directly from Windows' contextual menus.

HENRY BORTMAN is *Macworld's* senior technology editor.

With Diamonds
This Perfect,
The Only Thing
We Cut
Are The Prices.

Mitsubishi's full line of award-winning DIAMONDTRON™ aperture grille monitors have a proven reputation for quality, reliability, and value. And now you can get all this at prices lower than ever before. Plus, you'll have added confidence knowing that all Mitsubishi Diamond Plus® and Diamond Pro® Series monitors are backed by a full 3-year warranty, combined with service and support programs that are already the best in the business. With the new lower pricing, everyone can experience the DIAMONDTRON™ difference. Get all the details by contacting Mitsubishi Electronics today.



USA: 1-800-843-2515 • Canada: 1-800-387-9630 • Qwikfax: 1-800-937-2094
World Wide Web: www.mitsubishi-display.com

Diamond Plus® Series

DIAMONDTRON displays for people who mean business

New!

Only \$1499
Diamond Plus 100e

- 21"/19.7" DVI*
- 1600 x 1200/85 Hz
- 30-108 kHz auto-scan range
- USB-ready

Reduced to \$679
Diamond Pro 87TXM

- 17"/16.0" DVI*
- 1600 x 1200/66 Hz
- 30-86 kHz auto-scan range

New!

Only \$599
Diamond Plus 70

- 17"/16.0" DVI*
- 1280 x 1024/65 Hz
- 30-70 kHz auto-scan range

Diamond Pro® Series

DIAMONDTRON solutions for graphics professionals

New!

Only \$1799
Diamond Pro 1000

- 21"/19.7" DVI*
- 1800 x 1440/76 Hz
- 30-115 kHz auto-scan range

Reduced to \$1399
Diamond Pro 91TXM

- 21"/19.7" DVI*
- 1600 x 1200/75 Hz
- 30-95 kHz auto-scan range

Reduced to \$849
Diamond Pro 700

- 17"/16.0" DVI*
- 1600 x 1200/75 Hz
- 30-95 kHz auto-scan range



MITSUBISHI
DISPLAY PRODUCTS
Innovation On Displaysm

©1998 Mitsubishi Electronics America, Inc. DIAMONDTRON is a trademark of Mitsubishi Electric Corporation. Diamond Pro and Diamond Plus are registered trademarks of Mitsubishi Electronics America, Inc. Microsoft, Windows and the Windows logo are registered trademarks of Microsoft Corporation. Mac and the Mac OS logo are trademarks of Apple Computer, Inc. Monitor prices and specifications subject to change without notice. *DVI (Diagonal Viewable Image)

Circle 261 on reader service card

Essential
Software to
Stay Afloat
in Cross-
Platform Seas

Mac Life Preservers

BY GALEN GRUMAN

LIKE IT OR NOT, WINDOWS PCS ARE PROBABLY A

part of your life, but you don't have to sink in a sea of cross-platform incompatibilities. With the right tools, you can not only stay afloat but also cruise easily in the cross-platform waters. In the feature "Save Your Mac!" (elsewhere in this issue), we talk about strategies and problem solving for mixed Mac and Windows environments. Here we'll help you find software that will turn those tactics into action. No matter how you deal with Windows PCs, there's almost certainly a software option that will fit your particular needs. In this comparison, *Macworld* explores and rates 25 products.

Sharing Disks Successfully

The most common way to share with your Windows-using coworkers is to exchange files, whether you're swapping simple floppies or removables of other kinds. But there's a basic problem with cross-platform file exchange: the Mac and Windows operating systems use different methods of formatting and arranging files. As a result, disks typically won't mount, and even when they do, you can't double-click on file icons to open the files. Luckily, software tools can help you overcome this obstacle. The table "Breaking the Mac-PC Disk Barrier" sums up what's available for file exchange and how these tools rate with *Macworld*.



FRASER

Tools for the Mac The Mac OS comes with a built-in tool for helping you handle Windows PC media and files: PC Exchange. But in System 7.X and Mac OS 8.0, PC Exchange supports only the DOS-style file names, not the long file names you might encounter when working with users of Windows 95 or Windows NT 4. The new PC Exchange 2.2 in Mac OS 8.1 now handles Windows' long file names. However, *Macworld* still recommends a more powerful solution: Software Architects' (www.softarch.com) \$100 DOS Mounter 95 1.1.

In addition to mounting PC media and handling long file names, DOS Mounter 95 lets you choose how Mac files are saved to PC media: DOS-style (perfect if you still work with people using Windows 3.1 or NT 3) or with long file names (if you work with people using Windows 95 or NT 4).

Unlike PC Exchange, DOS Mounter 95 also lets you format Iomega Zip cartridges and other removable media in PC format, and it gives you more control over how files are *mapped* from one platform to another. Mapping determines what icons your files get and thus what programs will open when you double-click on them. DOS Mounter 95 lets you set up independent file maps; so you could, for example, have files with the file extension .tif (for TIFF files) be mapped to an Adobe Photoshop TIFF file when opened on the Mac but mapped to a Corel Photo-Paint TIFF file when opened on a Windows PC.

DOS Mounter 95 includes a utility



common mapping in a workgroup).

Software Architects also offers FormatterFive 3.1, a \$195 utility that incorporates DOS Mounter 95 (renamed as Mac-PC Manager) and includes enhanced drive-formatting options. FormatterFive lets you work with IDE drives and create Universal Disk Format partitions (used on DVD-ROM discs).

Tools for Windows PCs Mac users aren't the only ones who can smooth the waters of Mac-PC file transfer. Three programs can help Windows PC users read your Mac media.

Our favorite is the \$59 MacOpener 3.0, from DataViz (www.dataviz.com). It runs on Windows 3.1, 95, and NT 4.0 and has everything that most users need: the ability to read, write, and format Mac

Windows NT (though the forthcoming MacDrive 98, expected this spring, will). Like MacOpener, MacDrive 95 adds its Mac-formatting capabilities to Windows' contextual menus.

Once *Macworld's* top pick in this category, Software Architects' \$100 Here & Now 2.0 is showing its age. It covers the basics, but it doesn't support Windows NT and doesn't integrate Mac-disk formatting into Windows' contextual menus. Its one advantage is the ability to set up independent file mapping for Mac-to-PC and PC-to-Mac transfers, like its Mac cousin DOS Mounter 95 can. A new version expected this summer may again make Here & Now a top contender.

Avoid the truly awful Mac-in-DOS Plus 2.0, from NetUSA (formerly Pacific Microelectronics; www.netusa.com). Mac-in-DOS makes you use a time-wasting separate utility to copy files from floppies and removable drives to PC media, and vice versa. Mac-in-DOS is also terribly overpriced at \$129. Its only merit is that it automatically adds Mac file and creator types from unrecognized Mac files to its database, prompting you for the Windows file extension. However, this feature does not make Mac-in-DOS worth buying.

Sharing Over a Network

Many people who use Macs are a minority surrounded by Windows PC-using departments. Exchanging floppies and other media helps you work with the Windows hordes, but it doesn't help you collaborate on the network, where most corporate data exchange happens. The software options here are trickier, mostly because networks are configured differently from company to company. The table "Making Macs and PCs Talk Directly" sums up the options and gives *Macworld's* ratings for each.

The Future of Mac Networking At some point, Apple plans to base its networking future on the platform-independent TCP/IP protocol rather than on the AppleTalk protocol. (The Mac OS now offers both, although AppleTalk is by far the more dominant.) The standardization on TCP/IP will make it easier to integrate Macs into PC-dominant environments, since Windows 95 and NT use TCP/IP. Of course, you'll still need soft-

The network-sharing options are trickier, mostly because companies configure their networks differently

that lets you format SCSI-based removables and hard disks with Windows or Mac partitions. You can even partition a disk with one section formatted for Windows and one for the Mac OS. The application also includes the graphics-translation program GraphicConverter (covered later in this article). My only criticisms of DOS Mounter 95 are its price—\$100 is a lot, although the addition of GraphicConverter helps justify the cost for some users—and the fact that you can't copy its extension map to other Macs (to ensure

media; user-editable extension maps; and integration of Mac-formatting capabilities into Windows' contextual menus (see the screen shot "One-Touch Formatting").

If you need to work with Mac file resources or copy Mac disks from your PC while retaining their Mac formatting, you'll want the pricier (\$75) MacDrive 95 1.3, from Media4 Productions (www.media4.com). It lets you use a PC as a disk-copying workstation for Mac media, freeing your Mac for more-interesting work. MacDrive 95 does not run under

Can the Mac Really Do Windows?

IT HAPPENS TO NEARLY EVERY MAC USER

at some point: your boss or client insists that you use a Windows-only application, or the

new game you're dying to play isn't available for the Mac. What's a loyal Mac user to do?

There's no easy answer; it depends on your needs, your budget, and your desk space. But if you need to run lots of Windows applications on a regular basis, your best choice is to just buy a low-cost Windows PC. The alternatives are mediocre replacements, and *Macworld* recommends them only in specific cases.

Software Emulation If your budget is tight and you need to run only a few Windows applications, the cheapest option is a software emulator—a program that poses as an Intel-standard PC and lets you run DOS and Windows applications on your Mac. But this alternative is also *slow* and requires lots of RAM and hard-disk space—your Mac should have at least 32MB of free RAM and 250MB of hard-disk space available.

Macworld Lab tested Insignia Solutions' (408/327-6000, www.insignia.com) SoftWindows 95 4.0 (\$199; **★★**) and Connectix's (415/571-5100, www.connectix.com) Virtual PC 1.0 with Windows 95 (\$149; **★★**). Neither impressed us, especially given the changes in the emulation market since the last time we reviewed them. SoftWindows 95 ran our tests an average of five times slower than a poky 90MHz Pentium PC, and the cheaper Virtual PC crawled along at about half the speed of SoftWindows 95. Emulation-software performance can benefit from a few tweaks (see "Have Mac, Will Do Windows," January 1998), but be prepared for overall sluggishness.

PC-Compatibility Card If you need to devote significant time to running Windows applications, you need speed. If you have zero spare desk space or if your company won't support PCs, consider a PC-compatibility card—a PCI card that includes a Pentium-compatible processor and RAM dedicated to running DOS or Windows.

We tested Orange Micro's (714/779-

2772, www.orangemicro.com) OrangePC 550 AMD-K6 233MHz card (\$1,549; **★★★**). Its speed is impressive—nearly as fast as a \$1,800 233MHz MMX Pentium PC on both tests. But for what you spend on the card, you could buy a midrange Windows PC. Radius (408/541-6100, www.radius.com) offers a lower-priced option with its Detente line of Pentium-based PC-compatibility cards, formerly sold by Reply as the DOS on Mac cards, but Radius declined to lend Macworld Lab evaluation units. Apple has discontinued its PC-compatibility cards.

Screen Sharing If your company has a spare PC on its network, you can use screen-sharing software to access it without making room for it on your desk. Screen-sharing software, such as Netopia's (510/814-5000, www.netopia.com) Timbuktu Pro 4.0 (\$139; **★★★★½**), displays a remote Mac's or PC's screen in a window on your Mac. You interact with normal Mac keyboard input. It's faster than emulation but is still relatively slow. This option is best for occasional PC use in a largely Mac environment; it also lets

multiple people share the PC, although only one person at a time.

Macworld's Buying Advice

There's really no choice for most Macintosh users: bite the bullet and put a PC next to your Mac. Add connectivity software to exchange disks and data and use a switch-box to share a monitor, and you'll have the best of both worlds.

Assistant Lab Director SUSAN SILVIUS tests everything from networks to little black boxes.



Intel Inside, Mac Outside

Running Windows on your Mac is not usually the best solution. Software emulation was painfully slow in our tests, screen-sharing performance was only slightly faster, and PC-compatibility cards were speedier but not a good value. Your best bet? Buy a cheap PC.

■ Best result in test. All times are in seconds. Shorter bars are better.

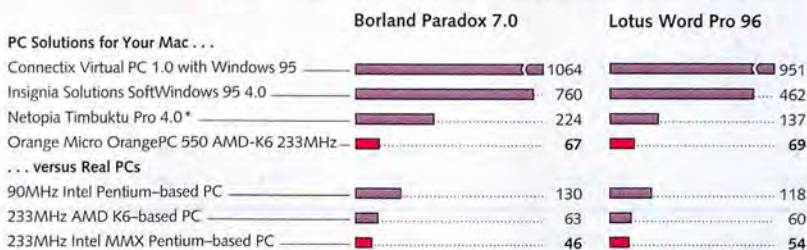

* Controlling a 200MHz Intel Pentium-based PC.

Behind Our Tests

Tests were from Ziff-Davis's WinStone 97 benchmark. SoftWindows and Virtual PC were tested on a Power Mac 7300/200 with 64MB of RAM, of which 32MB of RAM were dedicated to Windows 95. The OrangePC 550 card had 32MB of dedicated RAM. Each PC had 32MB of RAM.—Macworld Lab testing supervised by Susan Silvius

EDITORS' CHOICE

None For the vast majority of users, making room for a low-cost PC alongside your Mac is the most sensible way to run PC software. The other options are good only in limited, specific cases.

REAL PRODUCTS REAL RATINGS

Reviews you can trust *Macworld* rates only final shipping products, not prototypes. What we review is what you can actually buy.

Breaking the Mac-PC Disk Barrier

PC-BASED SOFTWARE					PC OPERATING SYSTEMS				SUPPORTED MEDIA			
Company	Product	Mouse Rating	List Price	Phone Number	Runs from DOS Prompt	Runs from Windows 3.1	Runs from Windows 95	Runs from Windows NT 4.0	Floppies	Removable Disks	CD-ROMs	SCSI Hard Drives
DataViz	MacOpener 3.0	★★★★½	\$59	203/268-0030	●	●	●	●	●	●	● ^A	●
	Conversions Plus 4.0	★★★★	\$99	203/268-0030	●	●	●	●	●	●	● ^A	●
Media4 Productions	MacDrive 95 1.3	★★★★	\$75	515/225-7409	●	○	●	○	●	●	●	●
NetUSA	Mac-in-DOS Plus 2.0	★★	\$129 ^B	415/948-6200	● ^B	● ^B	● ^B	● ^B	●	●	○	○
Software Architects	Here & Now 2.0	★★★	\$100	425/487-0122	●	●	●	○	●	●	● ^A	●

MAC-BASED SOFTWARE					PC FILE OPTIONS				SUPPORTED MEDIA			
Company	Product	Mouse Rating	List Price	Phone Number	DOS/Win 3.1 (FAT16)	Win 95/NT 4 (FAT16)	FAT32 ^C	NTFS ^D	DOS and Long File Names	Floppies	Removable Disks	CD-ROMs
Apple Computer	PC Exchange 2.2 (Mac OS 8.1)	NA ^E	free ^E	408/996-1010	●	○	○	○	○	●	○	●
Software Architects	DOS Mounter 95 1.1	★★★★	\$100	425/487-0122	●	●	○	○	●	●	●	●
	FormatterFive 3.1	★★★★	\$195	425/487-0122	●	●	○	○	●	●	●	●

Making Macs and PCs Talk Directly

					TYPE OF NETWORK				SUPPORTED PLATFORMS	
Company	Product	Mouse Rating	List Price ^F	Phone Number	Lets Macs Use PC Volumes	Lets Macs Use PC Printers ^G	Lets PCs Use Mac Volumes	Lets PCs Use Mac Printers	Windows 95	Windows NT 4.0
Citrix Systems	NTrigue 3.0	★★½	NA ^H	954/267-3000	● ^I	● ^I	○	○	client	server
Cooperative Printing Solutions	COPSTalk 2.5	★★★★½	\$159	770/840-0810	○	○	●	●	client	○
Microsoft	NT Services for Macintosh	NA ^J	free ^J	425/882-8080	● ^K	●	○	○	○	server
Miramar Systems	PC MacLAN 4.0 (Windows NT)	★★★★	\$249	805/966-2432	●	●	●	●	○	server/client
	PC MacLAN 6.2 (Windows 95)	★★★★½	\$199	805/966-2432	●	●	●	●	server/client	○
	PC MacLAN Remote (7.0)	★★★	\$179 ^L	805/966-2432	●	●	●	●	server/client	○
Netopia	Timbuktu Pro 4.0	★★★★½	\$139	510/814-5000	●	○	●	○	server/client	server/client
Thursby Software Systems	Dave 2.0	★★★★½	\$119	817/478-5070	●	●	●	●	server/client	server/client

Editors' Choice winners in red. ● = yes; ○ = no; NA = not available. ^A Can be configured to mount both volumes of Mac/PC dual-format CD-ROMs. ^B Must buy separate version for DOS/Windows 3.1, ^C Part of Mac OS 8.1. ^D Prices for single license; companies offer multiuser discounts. ^E Driver file or Infowave's PowerPrint required for non-PostScript printers. ^F Product recently sold to Citrix, which is repricing can be made accessible to Macs. ^G Also sold with PC MacLAN 6.2 as the \$249 Pro Pack.

OS INTEGRATION			
Uses Contextual Menus	User Controls Use of File Extensions		Other Features
●	●		Displays Mac creator information for files.
●	●		Displays Mac creator information for files; converts file formats.
●	●		Displays Mac resource and creator information for files; MacDrive 98 to support NT 4.
○	○		A stand-alone utility that does not integrate into Windows' standard disk- and file-management functions.
○	○		Lets you map files to different programs based on direction of transfer (Mac to PC or PC to Mac).

SCSI Hard Drives	OS INTEGRATION			
	Uses Contextual Menus	Displays File Information		Other Features
●	○	○		Doesn't support removable media.
●	○	●		Allows direction-specific extension mapping; can create DOS partitions on SCSI drives.
●	○	●		Formats removable SCSI and IDE media with Mac and PC partitions, plus offers DOS Mounter 95 features.

Mac OS	SUPPORTED PROTOCOLS			
	LAN Access	Dial-up Access		Other Features
client	TCP/IP	○		Application server for Windows NT, 95, and 3.1 programs; requires extra-cost Mac client.
server	AppleTalk, TCP/IP	to Mac (AppleShare IP)		Connects to AFP-over-IP servers, plus to any Macs on a LAN using Windows networking standards.
client	AppleTalk	○		Lets NT Server act as a shared file server for Macs and PCs; uses Mac's Chooser as client.
server/client	AppleTalk	○		Creates a peer-to-peer Mac/PC network; uses Mac's Chooser as Mac client and AppleTalk as Mac server.
server/client	AppleTalk	○		Creates a peer-to-peer Mac/PC network; uses Mac's Chooser as Mac client and AppleTalk as Mac server.
server/client	AppleTalk	to Mac (PPP on ARA 3.0)		If used with PC MacLAN 6.2, requires restarting between LAN and remote access.
server/client	AppleTalk, IPX, TCP/IP	○		Combination screen-sharing and file-transfer utility rather than a typical volume mounter.
server/client	TCP/IP	to Windows 95, NT (RAS)		Lets Macs and PCs with TCP/IP establish peer-to-peer networks; costs less than competitors.

^a Windows 95, and Windows NT 4. ^c Windows 95 OSR2, 98, and NT 5.0 disk-format type. ^d Optional Windows NT disk-format type. ^e Only within PC programs being run remotely from NTrigue server. ^f Part of Windows NT 4 Server. ^g Only NTFS volumes

ware that helps Windows PCs and Macs share the files over the network, since even if the two platforms use the same networking protocols, there are still the issues of conflicting file and disk formats and of different sharing protocols.

Today's Solutions At the very least, you want your minority Macs to access Windows PCs and printers. Both PC MacLAN, from Miramar Systems (www.miramarsys.com), and Dave 2.0, from Thursby Software Systems (www.thursby.com), do that well, but they tackle the problem from different starting points: you add PC MacLAN to your Windows PC, while you add Dave to your Mac. If you have more Macs than PCs, it makes sense to use PC MacLAN. If PCs dominate, Dave is the better choice.

Best Tools for a PC Minority By adding AppleTalk networking functionality to Windows, PC MacLAN makes any Windows PC into a file and print server for Macs, and it lets the PCs see Macs with file sharing turned on as file and print servers. There are separate versions for Windows 95 (version 6.2, \$199) and Windows NT (version 4.0, \$249), as well as a Windows 3.1 version (5.5), which Miramar is giving free to K-12 schools (it's no longer sold commercially). Miramar would do well to sell these as one product for either platform, to ease the burden of IS managers dealing with Windows 95 and NT systems on the same network.

If you need to access a Mac network remotely—from your Windows notebook, for example—there's just one product that can help: Miramar's PC MacLAN Remote (version 7.0) for Windows 95. The company has no plans for an NT version of PC MacLAN Remote, because Microsoft plans to add this capability in Windows NT 5.0, due out in late 1998 or early 1999.

PC MacLAN Remote has two flaws. It's expensive (\$179), and you have to restart your PC each time you want to switch your connection (between remote and LAN cross-platform access) if you use PC MacLAN Remote with PC MacLAN 6.2. (Miramar sells the two products bundled together for \$249 as the PC MacLAN Pro-Pack.) Miramar says it is working on an upgrade that won't require such restarting.

A bug in the various PC MacLAN products can prevent America Online users from seeing their network adapters when configuring the Miramar network settings in Windows' Network control

panel. You can use keyboard arrow keys to scroll through the pop-up menu of adapters until you find the hidden network adapter; the company plans to have a fix on its Web site by the time you read this.

All versions of PC.MacLAN smoothly integrate into Windows, making Mac volumes and Mac printers accessible through the standard Network Neighborhood interface like any networked PC or PC printer. My only criticism of the PC MacLAN family is its high cost: prices range from \$179 to \$249 depend-

ing, PC users will see Macs and Mac printers through the standard Windows Network Neighborhood interface and Macintosh users will see PC volumes through the Chooser.

At \$119, Dave is a much cheaper buy than PC MacLAN, and Dave supports all flavors of Windows in one program. But PC MacLAN is much simpler to set up and doesn't have the one-network-at-a-time limitation, because it is PC-based. I prefer PC MacLAN because it has fewer hassles, but Dave's complexity is

.com). Its support of the Mac's new TCP/IP and AppleTalk File Protocol-over-IP functions means you can connect PCs to Mac-based Internet servers, which Web publishers in particular may find handy. It's also easier to set up than Dave.

Running PC Software Over the Network

Many Mac users in large companies need access to central resources, such as files and printers, and PC MacLAN and Dave both allow such access. But if you also want to run a few Windows programs on your Mac, you'll need a separate solution. You could get a PC Card or emulation software—as the sidebar, “Can the Mac Really Do Windows?” describes—but there are other options too.

The Best Choice The simplest option is the \$139 Timbuktu Pro 4.0, from Netopia (formerly known as Farallon Communications; www.netopia.com). This software lets you remotely control a Mac or a Windows PC from another workstation. What's particularly useful about this is that the system being controlled does not have to be the same platform as the one controlling it, so you can run Windows programs in a Mac window or vice versa. Timbuktu also provides file exchange and basic messaging (such as chat).

Things to Avoid A more complex possibility is NTrigue 3.0 (pricing was unavailable at press time), formerly from Insignia Solutions but recently sold to Citrix Systems (www.citrix.com). NTrigue's application server runs on Windows NT, which means that multiple computers, be they Macs, PCs, or Unix workstations, can simultaneously run programs that reside on the NT server.

Besides other limitations, NTrigue is based on an outdated version of NT—3.5—that won't run most current Windows 95/NT software, and the NT 3.5 interface is so awful that

Practically every popular program is cross-platform now, so there's less need for special file-translation tools

ing on the version you buy, compared with \$119 for Dave.

Best Tool for a Mac Minority The Mac-based Dave uses the Mac's native TCP/IP and adds Windows' NetBIOS protocol to give the Mac the appropriate networking protocols to connect to a Windows 3.1, 95, or NT PC. Many Mac users will appreciate that Dave doesn't require any software installation on the PCs, so you can connect your Macs without the help of your IS staff.

But don't get too independent: configuring Dave requires details about the Windows networking configuration on the PCs you're working with. You'll likely need a PC pro's help. For those not comfortable with nitty-gritty networking, PC MacLAN is far easier to set up.

Dave's only significant design drawback is that it relies on PC Exchange's extension mapping to display icons of files across the network—this is unfortunate if you're using DOS Mounter 95, which we recommend over PC Exchange.

Dave also suffers from a limitation of the Mac OS's networking implementation: you can have only one active TCP/IP connection. If you are using Dave to connect to a PC and want to dial in to an Internet service provider, you'll have to disconnect from the network, change your TCP/IP control panel's configuration to a dial-up connection, restart your Mac, and then dial the Internet connection. Apple has said for several years that it will fix this problem but still hasn't done so.

Once you have Dave up and run-

caused by the Mac OS, not by Thursby's implementation.

Other Options Although most people will prefer products such as PC MacLAN and Dave that provide bidirectional Mac-PC networking, some people might consider the \$159 PC-to-Mac-only COPSTalk 2.5, from Cooperative Printing Solutions (www.copstalk

One-Touch Formatting



MACOPENER 3.0 AND MACDRIVE 95 1.3 BOTH add Mac-disk-formatting capabilities into Windows' contextual menus.

Windows Beauty Tips

Help Your Windows PC Discover Its Inner Mac



BY GALEN GRUMAN
AND INGALL W. BULL III

can see the before and after in the screen shots on the facing page. You don't need to do all the steps—just pick the ones that give you the degree of Mac-ness you want.

Make It Work Like a Mac

- **Move the Start menu to the upper-left-hand corner of your screen.** The Windows Start menu is

IF THE WINDOWS INTERFACE WERE YOUR BLIND DATE, YOU'D probably describe it as having a "good personality." However, all is not lost in this beauty contest: it's amazing what a little Mac makeover can do for Windows' click appeal. Believe it or not, even if you have to use a Windows machine, you *can* make it look and—to a certain extent—act like a Mac. Hope springs from the fact that you're not the first Mac user who's had to use Windows. Those who went before you created some nifty tools to ease your pain. There's a bunch of shareware that brings more of the look-and-feel of the Macintosh to Windows. You'll have more success customizing a Windows 95 PC than one running Windows NT, but there's hope for NT users too.

All the software mentioned here is free, unless otherwise noted, and is available from Macworld Online at www.macworld.com/more/ or at <http://mac95.home.ml.org>. The installation instructions that come with the software are misleading, so be sure to read *Macworld's* instructions first. Finally, only a few of these shareware packages work with Windows NT 4.0; unless we say something works with NT, assume that it does not.

We walk you through the steps of a Windows makeover. You

the equivalent of the Mac Apple menu, so go ahead and put it where it belongs. All you have to do is click on the gray Task Bar where it's located and drag up toward the new location.

- **Sort out the menu bars.** One of the annoying side effects of moving your Start menu to the top of your screen will be that application menu bars will cover it because they expect the Task Bar to be at the bottom. To solve this problem, you can install the \$15 shareware program *Shove-It*, from Phil Hord. *Shove-It* shifts application menu bars down and out of the way. (If this doesn't seem to work, right-click on the Task Bar, select Properties, and make sure the Always on Top option is selected.)

- **Get your desktop icons in order.** First, move the My Computer, Network Neighborhood, and other Windows desktop icons to the right-hand side of your screen. Then open the My Computer and Network Neighborhood icons and drag the icons for your system's disk drives contained therein (3½ Floppy, Hard Disk C, Hard Disk D, CD-ROM Disc, and so forth) to the desktop; Windows will make aliases for them on your desktop, so you can position them like you would the Mac's standard drive icons.

- **Use the Mac's standard menus.** To get most of the standard menus that run across the top of your Mac—Apple, File, Edit, View, and Special—install *WinMac*. This shareware program reorders Windows functions to match the order of their

Mac equivalents. Note that this menu does not replace the Start menu, so if you install WinMac, be sure to leave the Start menu on the bottom of the desktop; otherwise, the Start menu will obscure WinMac's menus.

Make It Look Like a Mac

- **Make Windows 95 use the real Mac interface.** If you're running the Microsoft Plus Pack, there's an easy way to get that authentic Mac look rather than the pale version appropriated by Microsoft: install the Mac95 desktop theme. This shareware transforms your desktop icons, pointers, fonts, and sounds to Macintosh incarnations and installs a Mac-like folder called Control Panels in your Start menu. To run Mac95, you'll need to run either the Themes program from the \$50 Microsoft Plus add-on package or the \$15 shareware program Theme Plus.

- **Make it Mac from the start.** Get a Mac start-up screen by installing the Mac95ivs shareware program. Note that this requires you to install the Microsoft TweakUI program (which you can download from www.microsoft.com/windows95/info/power toys.htm) and use it to disable the normal Windows splash screen. Also, this start-up screen was designed to work with 640-by-480-pixel displays and will look chunky on a higher-resolution monitor.

- **Satisfy your logo envy.** Replace the Windows logo in the Start menu with an Apple logo by installing the MacBar shareware program.

- **Get the Mac OS 8 look.** We think Mac95's System 7-style icons are not as attractive as Mac OS 8's, so we use the icons from John Beckett's Icon Pack 1 instead.

- **Use your favorite desktop patterns.** You can use any Mac desktop pattern on a PC. Simply drag the pattern from the Mac's Desktop Patterns control panel to the desktop, making a clipping file. Import that clipping file as a PICT Resource in Adobe Photoshop, and then save the imported file as a BMP file, Windows' native format. (Be sure to append the file extension .bmp so that Windows *knows* it's a BMP file.) Transfer that BMP file to the PC, putting the file in the main Windows directory with the other Windows desktop patterns. Then change desktop patterns in the Display control panel's Background tabbed pane. We've converted 24 Mac desktop patterns for you, which are available on the *Macworld* Web site along with several dozen Mac-like patterns. **m**

GALEN GRUMAN, *Macworld's* editor, has used Macs as well as PCs since they were introduced nearly 15 years ago. INGALL W. BULL III is a social worker and manages Macs and PCs for several high schools.

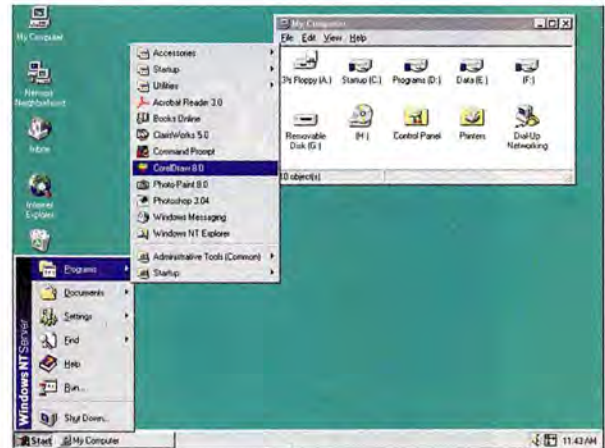

Before The original Windows 95/NT interface.



After Behold! The Windows interface revamped with the Mac look.



A Different Look Experiment with these tips to create a custom Mac look for your PC. For example, try the WinMac shareware program to add a real Apple menu.

"Wow, look what's inside the best color scanners!"

The world's best color scanning software. If you think all scanners are pretty much alike, you're partially right. The hardware is similar. But what makes a scanner perform is the software. And when it comes to software, there is nothing like LinoColor™. VisualLab™. VisualLab is based on our more than 40 years' experience working with professional quality color. In fact, LinoColor technology is now the industry's

color standard – adopted by both Apple and Microsoft for use in their operating systems. So why settle for just a scanner when a LinoColor scanner delivers what you really want – great scans?

To learn more about how easy great scanning can be, call for our free brochure today: **888-LINOCOLOR**. Or get it on the Web at www.linocolor.com



The world's best color scanning software. And it's the industry standard.



LinoColor
Color is child's play.

LinotypeCPS

©1997 LinotypeCPS. Linotype is a registered trademark, and LinoColor and VisualLab are trademarks of Heidelberger GmbH and/or its subsidiaries. Macintosh is a registered trademark of Apple Computer, Inc. Windows is a registered trademark of Microsoft Corporation.

For Macintosh® or Windows®

Circle 17 on reader service card

Publishing Power Play

**This Speedy NT
System Was Made
for Mac Pros
Like You.
Is the Switch
Worth Making?**

BY BRUCE FRASER

IT'S FAST, *REALLY* FAST. IT RUNS ADOBE PHOTOSHOP ABOUT 25 PERCENT QUICKER THAN Apple's top-of-the-line 266MHz Power Mac G3. It's targeted at the throngs of publishing professionals who rely on the Mac to get their jobs done. Sounds like a natural, right? There's just one catch: this computer is a 300MHz Pentium II-based PC that runs Microsoft Windows NT 4.0, not the Mac OS. Microsoft and PC vendors are making a power play for the publishing market, traditionally a Mac stronghold. Over the past few years, Windows NT has made significant inroads into the desktop-video and 3-D-graphics arenas. Now Microsoft is touting Windows NT as "the publishing platform" as well. Big PC companies are joining old-line workstation



The Intergraph
ExtremeZ 2D
Graphics
Workstation is
fast, but is it
publishing-savvy?

companies to persuade Mac users to buy NT workstations. Even Mac licensee Umax Computer will debut an NT PC.

I've been using Macs faithfully since February 1984, and most of that time I've been skeptical about Microsoft's understanding of my world—graphics and publishing. So has Microsoft changed? Is Windows NT 4 *really* a suitable platform for publishing professionals?

To find out, *Macworld* decided to try out the system that may be the best-case scenario for integrating Windows NT into a primarily Mac OS work environment: the new Intergraph ExtremeZ 2D Graphics Workstation. Sure, the ExtremeZ 2D is fast, but how challenging would it be to plop it—wanted or not—into a Mac-based studio?

First Impressions

The only major difference between starting up the ExtremeZ 2D and starting up a Mac is that with an NT system, you have to log on. Windows NT comes with an account already defined—the user name is Administrator, and there's no password—you can log on immediately.

Getting Started After that, Intergraph's preinstalled software took care of the nitty-gritty. Miramar Systems' PC MacLAN software made connecting to my existing AppleTalk network about as simple as possible (for more on cross-platform tools, see the feature "Mac Life Preservers," elsewhere in this issue). I mounted all my shared Mac volumes on the NT system's desktop. And after enabling sharing in PC MacLAN, I

You'll find counterparts to almost all mainstay Mac software—but plug-in support is weak

mounted the NT system's shared volumes on my Macs, too. Reading Mac floppies wasn't a problem, either, thanks to DataViz's MacOpener 3.0.

The Intergraph system also comes with your choice of several different software bundles preinstalled. Conveniently, the software that publishing pros use—QuarkXPress; Macromedia FreeHand; and Adobe PageMaker, Photoshop, and Illustrator—all have compatible Windows NT and Mac OS versions that read each other's files and have surprisingly

Different Windows



WINDOWS NT HAS A MAC-LIKE INTERFACE, BUT it's not a complete clone. Each application window has its own application menu, and any programs or files open are displayed in the Task Bar.

consistent interfaces. However, if you rely on plug-ins, you'll find the Windows selection pathetically small.

All in all, I was surprised at how easy it was to get started with Windows NT. But as I went about my work, there were still plenty of reminders that I wasn't using a Mac. Some of these issues were minor annoyances, but others were serious.

User Interface NT 4.0's user interface is different from that of the Mac OS in terms of its layout. However, it's somewhat customizable (see the feature "Windows Beauty Tips," elsewhere in this issue) and isn't difficult to learn well enough to get your work done.

The Windows Task Bar lets you open applications and documents, somewhat like the Mac's Apple menu, although each application's menus appear inside the

application window. The Task Bar contains icons for all currently running applications and for windows for local and networked volumes (see the screen shot "Different Windows").

You can "minimize" NT's windows—which is like using the Mac's Window-Shade feature. The Task Bar gives you a quick way to expand them again. It's not very Mac-like, but it's very convenient.

Viewing Files NT's options for viewing volumes, files, and folders are primitive compared with Mac OS 8's

Finder. I found myself missing things I take for granted on the Mac, such as being able to expand and contract multiple levels of folders within one window.

Find I also found NT's Find command surprisingly limited—no Boolean searches, and only limited searching for partial file names. You can't, for example, search for documents whose names *don't* end with .2—under NT, you can search only for names

that begin with, contain, or end with a specific string of characters and only by using DOS wild-card syntax. Typically this means you have to be much more organized both in how you name files and where you save them.

File Names Windows applications won't deal with Mac files unless you include the appropriate three-character extension at the end of the file name (.tif for TIFF files, for example) or change the settings in the programs' Open dialog box to display all files, using the All Files (*.*) option. Unless the file has a recognized extension, you can't double-click on it to open it from the desktop or from a folder. Note that Photoshop requires you to have .psd extensions on file names. Without this extension, you can't open Photoshop files under NT.

You may also have problems with long Windows NT file names (such as "really pretty red and blue boats somewhere in Connemara, Ireland") that the Mac, with its 31-character limit, can't display. (Windows NT can support file names up to 253 characters in length.) Reconciling file names across platforms is simply something you have to learn to deal with in a cross-platform environment. (See the feature "Save Your Mac!" elsewhere in this issue, for solutions.)

File Translation Another problem arises from the fact that the Mac OS and Windows use different encodings for the upper 128 ASCII characters. I found it mildly disconcerting that the name "Bruce's Macintosh" showed up in Windows as either "Bruce[213]s Macintosh"

How Does the ExtremeZ 2D System Rate?

THE INTERGRAPH EXTREMEZ 2D GRAPHICS Workstation is clearly targeted at Mac users. Its preinstalled AppleTalk connectivity and publishing-software bundles are all aimed at making it as easy as possible to add a Windows NT workstation to a network of Macs.

While Intergraph's attempts to make Windows NT Mac-friendly are admirable, let's be clear on the real source of the Intergraph system's appeal: it's *really* fast.

Speed Thrills

The \$8,622 system we tested was powered by two 300MHz Pentium II CPUs; 256MB of RAM; and three 10,000-rpm 4GB Ultra Wide SCSI drives, two of which were striped to form an 8GB array. (The workstation can accept up to 512MB of RAM. To rig up a comparable Apple Mac is impossible today, as the G3 Macs top out at 384MB of RAM. Only Umax Computer's SuperMac S900 line has enough RAM slots and drive bays.) The \$4,995 base model has one 300MHz Pentium II, 64MB of RAM, and one 4.3GB hard drive.

Macworld Lab's results show how Intergraph's performance-oriented technology choices paid off: the ExtremeZ 2D significantly outpaced the Macs in most Photoshop tests. For QuarkXPress and MetaCreations' Infini-D,

though, the ExtremeZ 2D's speed advantage was smaller.

Speed doesn't come cheap. A comparably equipped Umax SuperMac S900Base with Maxpowr Pro+ 250 (510/226-6886, www.supermac.com) with an 8MB Seagate Cheetah, like the one we tested, costs about \$6,900. A similarly equipped Apple Power Mac G3 266 tower (408/996-1010, www.apple.com), costs about \$6,300.

The ExtremeZ 2D isn't a clear bargain compared with high-end Macs. And the price of the ExtremeZ 2D doesn't include Windows versions of your applications and fonts.

Friendly Start-Up

Intergraph has done a splendid job of making its system easy for Mac users to set up, by preinstalling cross-platform connectivity software. Operations such as configuring the Windows swap file (NT's equivalent of virtual memory), setting up Photoshop's memory allocation, and configuring network services can be a real challenge, so it's nice that Intergraph has done that work for you.

Intergraph also offers several software bundles aimed at different graphics and publishing tastes. We tested the \$1,095 Designer bundle, which includes preinstalled versions of Adobe Photoshop 4 and Meta-

ExtremeZ 2D Graphics Workstation **★★★½**

PROS: Speedy, highly expandable, good bundled Mac connectivity.

CONS: Requires purchase of Windows programs and fonts.

COMPANY: Intergraph Computer Systems (205/730-5441, www.intergraph.com/ics/).

COMPANY'S ESTIMATED PRICE: \$8,622.

Apple Power Macintosh G3 266 Tower **★★**

Umax SuperMac S900Base with Maxpowr Pro+ 250 **★★★★**

For details on these Mac systems, see "PowerPC 750 Systems," *Reviews*, March 1998.

Creations' Painter 5 and Kai's Power Tools 3. The Designer bundle also includes a limited color-management application that only lets you view the effects of different profiles. The \$2,195 Pro bundle comes with Color Solutions' fuller ColorBlind package.

Macworld's Buying Advice

Intergraph has done a great job of delivering a Windows NT workstation that a Mac user can become productive with quickly. If someone held a gun to my head and forced me to buy a Windows system, I'd want to find a computer like this one: a system that's really plug-and-play and arrives preconfigured.

But despite Intergraph's yeoman efforts, the increase in speed isn't enough to compensate for Windows NT's publishing shortcomings. I'd still get a Mac.



Intergraph Takes on the Mac

There's no question: A fully loaded NT workstation outpaces fully loaded Macs in most publishing-oriented operations. You pay a higher price but get more performance. However, once you factor in the cost of software and the knowledge needed to take advantage of NT, as well as NT's limitations in some key areas, the speed's cost becomes more than just dollars.

■ Best overall performance. Longer bars are better. Bold indicates best result in a specific test. ▶ New system. An Apple Power Macintosh 7300/200 has a score of 1.0.

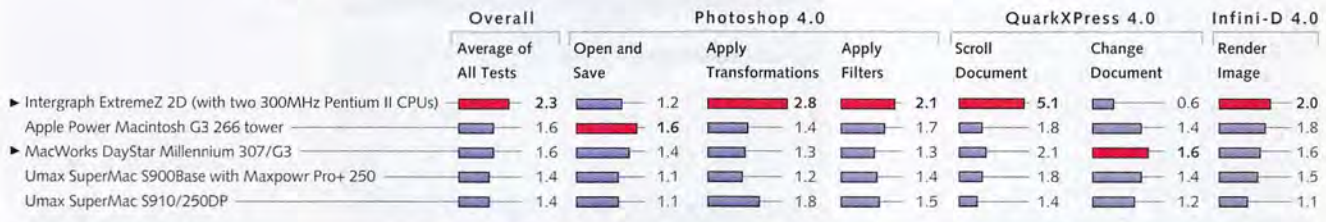

Behind Our Tests

Macworld Lab tested several operations in Adobe Photoshop 4.0, QuarkXPress 4.0, and Infini-D 4.0 to compare performance differences between Macs and PCs. The Macs had 256MB of RAM and 8MB of VRAM, and ran Mac OS 8.1. The Intergraph NT system had 256MB of RAM and 8MB of VRAM, and ran Windows NT Workstation 4.0. —Macworld Lab testing supervised by Susan Silvius

or "BruceOs Macintosh," depending on how I transferred it.

QuarkXPress and PageMaker translate some of these oddities automatically so that characters such as smart quotes are correctly handled, but occasionally the translation breaks down. For example, Windows has no ligature characters. At minimum, you need to proof type carefully whenever you send it between the

long time, it's the myth that Windows NT is far less crash-prone than the Mac OS. PC users know better, and so should you.

The truth is that NT does indeed crash. In the time I spent working with the Intergraph workstation, it crashed three times—and I mean the entire OS, not just the foreground application.

During this same period, my Power Mac 8100 crashed twice—Netscape Nav-

fonts on both platforms, you'll likely still run into problems translating special characters that aren't supported by Windows, such as the *fi* and *fl* ligatures.

Keeping Color in Sync Color management has gone from being the butt of many jokes to a vital component in publishing enterprises. On the Mac, I can display and edit accurate, reliable soft proofs in Photoshop, QuarkXPress, PageMaker, and any other ColorSync-aware application. With Windows NT, I can't even get CMYK files to look the same in Photoshop and QuarkXPress. There's no way to calibrate the monitor at the system level; on the Mac, there's one system-level video driver that all applications use, so Mac monitor calibration works across all applications. Photoshop presents a particular problem, because the Windows version uses a proprietary calibration routine that can't be turned off.

All this may change when Windows NT 5.0 hits later this year or early next year. But the plethora of legacy video cards and video drivers will continue to plague the Windows world long after the release of NT 5.0.

The Last Word

My introduction to NT was much less painful than I had feared, and even the most die-hard Mac bigot would have to concede that Intergraph has done a creditable job of integrating a Windows NT system into a Mac environment.

But even after using a Windows NT system designed especially for Mac users like me, I'm not quite ready to jump ship. Windows NT still feels like a work in progress: things are generally either reasonably easy to master or turn out to be impossible. You always have the impression that there's a behemoth lurking below the surface, ready to swallow you whole if you make even one misstep. For now, at least, I'll continue to plug away on my Macs—while keeping an eye on the competition. **m**

Contributing editor BRUCE FRASER is coauthor of *Real World Photoshop 4.0* (Peachpit Press, 1997).

People say NT is not crash-prone. PC users know better than that, and so should you.

two platforms, and you'll need to spend time correcting translation errors.

Drivers Printing was a little trickier under Windows, because each printer needs a driver. The installer wizard made installing the driver for an Apple LaserWriter very easy. For my NewGen Chromax dye-sublimation printer, I had to search further afield, but I managed to download the installer to a Mac from NewGen's Web site, transfer it to the ExtremeZ 2D, and run it to install the driver. Two hours after unpacking the machine, I'd made my first dye-sub print from a Windows system—so far, so good.

Scanners Finding the appropriate cable, downloading the appropriate drivers, and running the installer worked seamlessly in the case of a Hewlett-Packard ScanJet 3c scanner. Bear in mind, though, that not all scanners have Windows NT drivers, so you may not be able to attach an existing scanner as easily as I did. In a worst-case scenario, this could mean you'd have to buy a new scanner just for your new NT-based PC.

Colorimeters and More Serial devices required an adapter to go from the mini-DIN 8 plugs used by the Mac to the DB-9 plugs used on Windows PCs. However, serial devices—such as spectrophotometers, colorimeters, and other prepress must-haves—that also draw power from the ADB bus on the Mac require an external power supply for use with Windows. ADB devices are, of course, incompatible with Windows PCs. And even for serial devices, you may need driver or other configuration files.

Stability Issues If there's anything that users of Windows NT have hung over the heads of Mac users for a

igitor, not surprisingly, being the culprit—and my other three Macs, a DayStar Genesis MP 800+, a Power Mac 7100, and my venerable IIfx, didn't crash at all. This is a purely subjective observation, but I saw no evidence that Windows NT is much more stable than the Mac OS.

Publishing Problems

The problems I encountered that were due to my inexperience would be overcome quickly, although similar issues will eat up some time and money at any Mac shop adding NT. But there are some grave publishing-specific problems that even a best-case-scenario machine such as the ExtremeZ 2D can't overcome on its own.

Fonts While Fontographer 4.1 (\$495; **♦♦♦♦**), from Macromedia (+15/252-2000, www.macromedia.com), will convert Mac fonts to PC fonts and vice versa, something often gets lost in the translation. It's probably less painful and time-consuming to buy Windows versions of your fonts. If you own an extensive library, this could easily cost thousands of dollars. Even with the same

Font Variations



WINDOWS OFFERS DIFFERENT EXTENDED CHARACTERS than the Mac does (see the bottom row of this Key Caps-like utility that comes with Windows), and NT supports fonts that use the multilingual Unicode standard. But NT does not support ligatures.

MORE PHOTOSHOP® POWER FOR CREATIVE TYPES.
PRICED FOR TIGHTWAD TYPES.



TEXT EDITING, BUTTON BUILDING, EFFECTS GENERATING, IMAGE ENHANCING AND ORGANIZING TOOLS EVERY PHOTOSHOP USER'S JUST GOTTA HAVE!

The Extensis PowerSuite for Adobe® Photoshop®

Three essential productivity products for print, the Web and multimedia design every Photoshop user needs for one low price.

Extensis PhotoTools™ 2.0 — The new collection of seven productivity tools featuring *PhotoText* — the powerful WYSIWYG text editor for creating text blocks right in Photoshop.

PhotoButton — Quickly construct beautifully-rendered buttons.
PhotoCastShadow — The quick and versatile perspective shadow generator. And, create effects in seconds with *PhotoGlow*, *PhotoBevel* and *PhotoEmboss*.

Extensis Intellihance™ 3.0 — With a single click, Extensis Intellihance automatically and intelligently makes your images look their best. Six fine tune controls in one dialog eliminate up to 12 image adjustment steps in Photoshop.

Extensis Portfolio™ 3.0 — View, organize, share and use digital content like never before. Find any file anywhere — on your hard drive, CD-ROM, removable media and over networks. View all of your digital media as thumbnails or in a detailed list. Cross platform Portfolio works for workgroups. Multiple Windows and Mac users can create and share catalogs on a network at the same time.

The Extensis PowerSuite for Adobe Photoshop — Three award-winning products every Photoshop user needs for one low price.



DOWNLOAD A FREE TRIAL VERSION

<http://www.extensis.com>

Extensis and the Extensis logo are registered trademarks and PhotoTools and Portfolio are trademarks of Extensis Corporation. Intellihance is a trademark of DPS Software. Adobe and Adobe Photoshop are registered trademarks of Adobe Systems. Macintosh is a registered trademark and Mac is a trademark of Apple Computer. Windows is a trademark of Microsoft Corporation. All other trademarks are for identification purposes only and are the property of their respective owners.

EXTENSIS POWERSUITE
FOR ADOBE PHOTOSHOP
3 GREAT PRODUCTS!
ONE INCREDIBLE LOW PRICE!



SAVE
\$130⁰⁰

\$199.95

EXTENSIS POWERSUITE
FOR ADOBE PHOTOSHOP
WINDOWS AND MACINTOSH

1.800.796.9798

SOURCE CODE: 1087



ONCE YOU OUTGROW *zip*, AVOID THE *rip*.



*Dyna***MO**₆₄₀

**WE'LL PAY YOU \$150 TO
UNZIP YOURSELF.**

*Just buy a DynaMO 640 before
March 31, 1998, and send us your
old Zip drive. Call, or visit our
website for details.*



If your Zip can't keep up with your appetite for more capacity, it's time for an upgrade. Not to Jaz, but to DynaMO 640. It's less than one-third the cost of Jaz media*, with a 640MB cartridge costing just \$20. A figure that's even more remarkable when you consider all the things DynaMO 640 has over Jaz. It's more durable, you get free tech support, and you can save your work on different capacities ranging from 128MB to 640MB. And with our No Excuses™ policy, if anything goes wrong during the warranty period, you'll get a replacement drive in two business days. All of which means once you outgrow Zip, there's absolutely no reason to take up Jaz. For more details on DynaMO 640, call, or visit our website.

FUJITSU

(800) 462-0273 www.fcpa.com

©1997 Fujitsu Ltd. All rights reserved. Fujitsu and the Fujitsu logo are registered trademarks of Fujitsu Ltd. No Excuses is a trademark of Fujitsu Computer Products of America, Inc. Mail your Zip drive, DynaMO 640 original sales receipt, original UPC code and serial number to Fujitsu Computer Products of America. Promotion dates: 1/1/97 through 3/31/98. All other trademarks mentioned herein are the property of their respective owners. *PC Magazine Online 10/22/97.

Circle 202 on reader service card

MACWORLD LAB
CUTS THROUGH
THE CONFUSION TO
FIND THE BEST
56K MODEMS

The Modem Showdown



YOU DON'T WANT TO KNOW WHAT makes your modem tick. You care about Web surfing and e-mail, not the gory details of how your data gets from point A to point B.

But if you want to really speed up your connection to the Net by buying one of the new generation of high-speed 56-Kbps modems, you *have* to care, at least a little. If you don't, you could end up with a modem that's half as fast as you want it to be.

That's because choosing and using a modem have become more complicated than ever before, thanks to a feud between rival 56K-modem manufacturers and to the technological trickery the modem makers have used to push modem speeds higher and higher.

Macworld Lab ferreted out the truth behind 56K-modem vendors' hyperbolic performance claims, testing competing modems from each of the two warring camps—x2 and K56flex—14 in all, including both external and PC Card models. We discovered a few secrets that'll help you get the most out of your modem investment.

BY RIK MYSLEWSKI

56K Misconceptions

When we lump all these new, fast modems into the 56K category, shopping for one sounds like a simple exercise. But in truth, calling a modem 56K can create more confusion than it solves.

Incompatibility Problems Not all 56K modems are alike—for the moment, each 56K modem supports one of two protocols, each of which is completely incompatible with the other: *x2* and *K56flex*. And despite those promising names, don't believe that these modems will reliably speed your data along twice as fast as a now-out-of-date 28.8-Kbps modem. They won't.

Not Really 56K The figure 56 Kbps—designating the ability to transfer roughly 56K of data per second—is a theoretical top speed that's fiendishly difficult to achieve in the real world. What's more,

current FCC regulations limit even the theoretical top speed of *x2* modems in the United States to just 53 Kbps. (*K56flex* modems can theoretically achieve 56K speeds on U.S. lines.) The top-performing modem in our tests could muster an average speed of only 51.3 Kbps during a series of FTP downloads.

Download Only If you're expecting to be able to upload files to your Web server at top speed by using a new 56K modem, be prepared for more disappointment. The 56K modems can achieve high speeds only when you're *downloading* files, e-mail, or Web pages. When you're uploading, your 56K modem falls back to the old-style 28.8-Kbps or 33.6-Kbps maximum data rates. (For a look at high-speed alternatives to 56K modem technology, see the sidebar, "Toss That Modem: Alternatives to 56K.")

Inside Your Modem

As its name says, a modem *modulates*, or converts, a digital signal from your Macintosh into an analog signal so it can be sent over a phone system built to carry voices instead of data. When this signal reaches its destination, another modem *demodulates*, or converts, it back into digital information.

The Big Bottleneck That sounds simple enough—and it was, back in the old days when all phone lines were analog. But in the past few decades, the core of the telephone network has gone digital. Nowadays, when you place a call, it gets converted into a digital signal at your phone company's central office in your neighborhood and is routed over high-speed digital lines to a central office near your call's destination. That conversion from analog to digital introduces some



The Great Modem Race

While none of the modems we tested came anywhere near the 56-Kbps speeds their names would suggest, they did (with the exception of the Logicode Quicktel II-E 56XFP-E-M) offer a big speed improvement over their 33.6-Kbps predecessors. The 3Com Courier V. Everything 56K was the top scorer in our FTP download, the equivalent of a modem drag race. The Boca Research 56K Macintosh Modem was tops in the multifile Web download, a test in which both speed and agility were factors.

Best result in test. Longer bars are better. Editors' Choice winners' names are in red.

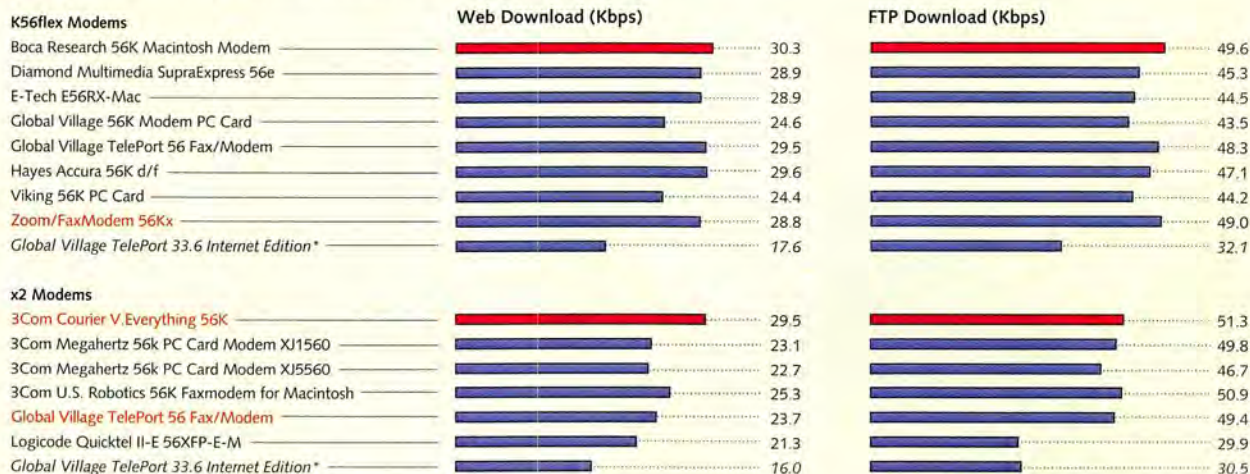

*33.6-Kbps modems tested for comparison.

Behind Our Tests

All the modems we tested dialed in to a Windows NT 4.0 remote-access server running Microsoft's Internet Information Server 3.0. The *K56flex* modems dialed in to a Rockwell I-WCEM server modem; the *x2* modems dialed in to a 3Com Courier I-modem. Our client machines were a Power Mac 7300/200 (for the external modems) and a PowerBook 3400c (for the PC Cards), both running Mac OS 8.0 and connecting via Apple's Open Transport PPP. For our Web download test, we used Netscape Navigator 3.0 to

download a frame set containing 32 different HTML, GIF, and JPEG elements totaling 680K. For our FTP download test, we used Fetch 3.0.3 to download a 2.4MB Stuffit archive containing a QuarkXPress document. We gave each modem 20 chances (10 for each test) to connect to our server and transfer the files. The final data above are performance averages for each test and therefore do not represent consistent, repeatable data-transmission rates.

—Macworld Lab testing supervised by Kevin Mitchell

noise into the connection. And that noise limits the speeds your modem can achieve.

The 56K modems bypass that bottleneck. Since most Internet service providers (ISPs) and remote-access servers are connected to high-speed digital phone lines, they just digitally encode data and pump it directly into the digital phone network, eliminating the noise-inducing analog-to-digital conversion.

One-Way 56K In the opposite direction, things aren't as rosy. Your data still has to undergo a noise-inducing analog-to-digital conversion, which limits your upload speeds to 28.8 or 33.6 Kbps, as it hops into the digital core of the phone system.

But really, is that so bad? If you're surfing the Web or downloading files from your corporate server, you need speed downstream, not up: you're sending compact commands and receiving bloated Web pages, JPEGs, or corporate databases.

If you spend a lot of time sending data—whether you're running a Web server or are uploading lots of files on a regular basis—you may want to consider sticking with a 28.8 or 33.6 modem.

When 56K Isn't 56K

So now we're all ready to crank up our modems and start downloading 56K's worth of data every second, right? Hold your horses.

Modem Mayhem The biggest problem with 56K modems has always been that x2 and K56flex modems simply don't work with one another, at least at 56K speeds. In other words, an x2-equipped client can't access a K56flex-equipped server at 56 Kbps, and vice versa. (They can still communicate with one another at the old-fashioned speeds of 28.8 or 33.6 Kbps, however.)

Because the performance of the two competing standards is essentially equal, the main reason to choose one over the other is compatibility with your ISP's modem. Although many ISPs claim to support both x2 and K56flex, be sure to ask yours how many ports it has dedicated to each type of access, to see if it favors one standard over the other.

Understandably, ISPs have been wary about which standard will become the dominant one, so many have been dragging their feet, waiting for a clear winner to emerge before they make a substantial investment in 56K technology.

Fortunately, that wait is about to end. In December 1997, the two sides stopped

TOSS THAT MODEM: ALTERNATIVES TO 56K

Our hurry-up culture has invented instant coffee, Instant Breakfast, and instant replay. So when can we expect to get instant Internet access?

Sorry, it'll take a few more years—but it will happen. Cable modems, for example, promise data rates in the 10-Mbps

will push for a unified xDSL standard may speed up that process, however.)

So are you limited to 56K performance until cable-modem or xDSL service is made available in your area? Thankfully, no. If you really need speed, there are alternatives available—for a price.



KEVIN CANDLAND

Using a Netopia ISDN router is just one of several faster-than-56K solutions that you can avail yourself of.

range—that's 200 times faster than even the best 56K modems.

Another promising technology is xDSL, a family of telecommunication schemes that uses existing phone lines to blast data from your ISP to your Mac at up to 6 Mbps.

But don't hold your breath: few cable companies have the infrastructure necessary to deploy cable modems, and few phone companies have committed to the investment required to provide widespread xDSL service. Although numerous field trials are under way, widespread deployment of either strategy seems unlikely until the next millennium. (Microsoft and Intel's recent announcement that the companies

Dual-Line One of the more ingenious solutions to the World Wide Wait binds two phone connections into a single data stream. If, for example, you connect your Mac to two 56K modems, each accessing your ISP over a separate phone line, you can theoretically achieve a 112-Kbps transfer rate.

Diamond Multimedia's dual-line modem technology, called Shotgun, will be added to all of its Supra-Express 56K modems later in the year. Expect other modem manufacturers to also offer dual-line technology later this year.

ISDN ISDN technology has been "promising" for so long that it's become an industry embarrassment. But there are encouraging signs that it

may at last be living up to its overhyped reputation. Most important is the fact that ISDN service is finally being offered at affordable prices in a wide variety of locations.

What's more, ISDN's notorious setup complexities are being overcome by such companies as Big Island Communications (650/237-0350, www.big-island.com), with its 128-Kbps Boogie Board (\$199), and Netopia (510/814-5000, www.netopia.com), with its eponymous series of cool-looking ISDN routers.

Frame Relay If ISDN is still too slow, frame-relay technology may be the way to go.

The beauty of frame relay is that you don't have to lease an entire high-speed line all by yourself; instead, a frame-relay provider books you space on its line, which you share with other subscribers. Most providers offer a variety of different service levels, from a mere 56 Kbps to a hot 1.53 Mbps.

Although frame relay isn't inexpensive—prices vary widely, depending upon location and bandwidth requirements—hardware needs are modest: a frame-relay-capable hub, and a router if you're switching protocols. Be warned, however: frame-relay service has become so popular that some service providers have overbooked their lines. And that means you may not always get the bandwidth you've paid for.

Shoot-out at the 56K Corral

Company	Product	Mouse Rating	List Price	Phone	Modem Type	56K Standard	Mac-Compatible Cable Included
	EDITORS' CHOICE						
3Com	3Com Courier V.Everything 56K	★★★★½	\$250	408/764-5000	external	x2	●
	Megahertz 56k PC Card Modem XJ1560	★★½	\$269	408/764-5000	PC Card	x2	NA
	Megahertz 56k PC Card Modem XJ5560	★★	\$289	408/764-5000	PC Card	x2	NA
	U.S. Robotics 56K Faxmodem for Macintosh	★★★	\$199	847/676-7010	external	x2	●
Boca Research	56K Macintosh Modem	★★★★	\$149	561/997-6227	external	K56flex	●
Diamond Multimedia	SupraExpress 56e	★★★★½	\$139	360/604-1400	external	K56flex	● (attached)
E-Tech	E56RX-Mac	★★½	\$149	510/438-6700	external	K56flex	DB-9 w/DIN-8 adapter
Global Village	56K Modem PC Card	★★★	\$269	408/523-1000	PC Card	K56flex	NA
Communication	TelePort 56 Fax/Modem (K56flex)	★★★★½	\$169	408/523-1000	external	K56flex	● (attached)
	EDITORS' CHOICE						
	TelePort 56 Fax/Modem (x2)	★★★★	\$169	408/523-1000	external	x2	● (attached)
Hayes	Accura 56K d/f	★★½	\$189	770/441-1617	external	K56flex	●
Logicode	Quicktel II-E 56XFP-E-M	★	\$219	800/735-6442	external	x2	●
Viking Components	Viking 56K PC Card	★★★	\$139	714/643-7255	PC Card	K56flex	NA
	EDITORS' CHOICE						
Zoom Telephonics	Zoom/FaxModem 56Kx	★★★★½	\$139	617/423-1072	external	K56flex	●

● = yes; ○ = no; NA = not applicable.

their bickering and announced an agreement that will lead to the adoption of a unified standard, V.PCM. An interim standard should be released by the time you read this, with formal ratification to follow in September.

Making the Upgrade The adoption of a unified standard is a necessary step toward the universal adoption of 56K technology, but the transition won't be seamless. The good news is that all the 56K modems we tested are equipped with flash ROM, making them easily upgradable to the new V.PCM standard—theoretically.

However, when we tried to upgrade some x2 modems to the latest version of the x2 modem firmware, we found it impossible to use 3Com's Web-based upgrade wizard to actually update any of our x2 modems. 3Com says it's working to fix the problem, but any prospective modem buyer should be wary, since the transition from x2 and K56flex to V.PCM could be even rougher than our attempted transition from x2 to an updated version of x2.

To their credit, every modem vendor with which we spoke promised to offer free downloadable upgrades to the V.PCM standard. In addition, Zoom Telephonics (www.zoomtel.com) and Logicode (www.logicode.com) will offer the upgrade on disk, Global Village Communication (www.globalvillage.com) promises to also put it on its AOL site, and Viking (www.vikingcomponents.com) will even provide

a brand-new V.PCM-compatible modem if you return your old K56flex Viking 56K PC Card.

The real problem is timing. If you upgrade your modem to V.PCM, there's no guarantee that your ISP will do the same—and there's no guarantee that an ISP's upgraded server modems will be able to accept calls from x2 and K56flex modems.



The Global Village TelePort 56 Fax/Modem (x2, top) and the Zoom/FaxModem 56Kx are our Editors' Choices in the x2 and K56flex categories, respectively.

Buying Today

Sure, there are possible pitfalls ahead, but there's still a lot to be said for buying a 56K modem today. Despite the caveats, it's hard to argue with the credo "Speed is good."

But do recognize that 56K modems are notoriously finicky. Our tests showed the performance of many to be wildly variable from test to test (see the benchmark, "The Great Modem Race").

The \$149 E-Tech (www.e-tech.com) E56RX-Mac, for example, would poke along at under 30 Kbps when we first began testing and then speed up to a full 50 Kbps after it warmed up. The \$139 Diamond Multimedia (www.diamondmm.com) SupraExpress 56e had exactly the opposite problem: it cranked along at over 51 Kbps when it first started up and then sank to below 35 Kbps after it warmed up. Even worse, the SupraExpress 56e dropped the connection more than twice as often as any other modem we tested.

Cool Runnings By far the most reliable—and the most expensive—of the external modems is the \$250 3Com (www.3com.com) Courier V.Everything 56K. If you need a modem for your business, this

Open Transport 1.2 CCL Included	Warranty (in years)
●	5
●	5
●	5
●	5
○	5
●	5
○	5
●	5
●	5
●	5
○	5
○	lifetime
○	5
●	7

is the one—and if your ISP doesn't support x2, change ISPs. One of the secrets of the Courier's success is that it runs cool; the digital signal processors in modems are very sensitive to temperature, a fact proved by the toasty and highly variable \$189 Hayes (www.hayes.com) Accura 56K d/f.

Heat was also the bane of all the PC Cards: they did poorly before they warmed up, and then they did poorly after they got too warm. If you plan to do serious surfing from your PowerBook, either stick with your current PC Card or buy a compact external model.

Our testers agreed that the \$169 Global Village TelePort 56 Fax/Modems were by far the most user-friendly and Mac-savvy of all. Their fax software is justly famous for its ease of use—although the competition's is getting better—and the modem-status information it provides in your Mac's menu bar is a useful aid in monitoring performance and diagnosing problems.

Mac-Friendly Modems Unless you are modem-savvy, you'll want a modem produced by folks who understand—and support—the Mac and its unique needs. One good way of determining whether a vendor is really committed to the Mac market is to see if it includes Open Transport CCL scripts, used by Apple's Open Transport PPP dialer (see the table, "Shoot-out at the 56K Corral").

Not only does Zoom have a long-standing dedication to the Mac but its

\$139 Zoom/FaxModem 56Kx was able to achieve the second-fastest throughput in our K56flex testing, with one file download topping out at a blazing 55 Kbps. The only K56flex modem that was faster was the \$149 Boca Research (www.bocaresearch.com) 56K Macintosh Modem, which turned in two astonishing runs: one at 55.5 Kbps and one at 55.3 Kbps.

Unfortunately, although the Boca has *Macintosh* in its name and includes a copy of Smith Micro's MacCommCenter fax and communications software, it lacks an Open Transport CCL script—not in the box, not even on the Web site.

Speed Champs Although the 3Com Courier V.Everything 56K consistently turned in the fastest times among x2 modems and the Boca Research 56K Macintosh Modem was the K56flex champ, all the modems but one turned in better-than-acceptable performances.

The lone disappointment was the \$219 Logiccode Quicktel II-E 56XFP-E-M. This futuristic-looking unit consistently turned in times comparable to those of a V.34 modem, and its file-download scores were particularly dismal. Logiccode's tech-support staff was unable to help.

Macworld's Buying Advice

Today, the best way to decide between x2 and K56flex technology is to ask your ISP how many access ports it has for each and then to buy a modem based on the best-supported standard. If you're a home surfer with an x2-centric ISP, we recommend the x2 version of the elegant Global Village TelePort 56 Fax/Modem. If your ISP prefers K56flex, go with the Zoom/FaxModem 56Kx; its Faxstf software may not be as nifty as Global Village's GlobalFax, but it absolutely screams—and it has enough status LEDs to keep you amused for hours.

If, on the other hand, you're a business type whose success depends on steady, reliable connections to your ISP or remote-access server, pony up the extra hundred bucks for an x2 3Com Courier V.Everything 56K. It's built like a tank, it can handle anything you throw at it, and it'll last forever. The Courier's so good that it's worth changing to an x2-equipped ISP.

If you have a PowerBook and are looking for a PC Card modem, the results are murkier. The PC Cards we tested weren't particularly impressive; if you're a hard-core PowerBook modem user, you

should consider buying an external modem or sticking with your current modem until the transition to the V.PCM standard is complete.

Of course, how well all the modems we tested will perform when upgraded to the new V.PCM standard is a question for the future—and the future's not here yet. For now, the best advice we can give is: Stay tuned. **m**

RIK MYSELEWSKI is managing partner of Smart-people, a technology-testing and -marketing group. He's been around long enough to have used 300-baud modems and acoustic couplers.

EDITORS' CHOICE

x2 Modem

★★★★ Global Village TelePort 56 Fax/Modem This reasonably speedy modem is easy to set up and use, has great software, and was designed with the Mac in mind. **Company:** Global Village Communication (408/523-1000, www.globalvillage.com). **List price:** \$169.

K56flex Modem

★★★★½ Zoom/FaxModem 56Kx Although the K56flex version of the Global Village TelePort 56 Fax/Modem is as good a buy as the x2 model, the fast, affordable, and feature-rich Zoom/FaxModem 56Kx is just a notch better. **Company:** Zoom Telephonics (617/423-1072, www.zoomtel.com). **List price:** \$139.

Business Modem

★★★★½ 3Com Courier V. Everything 56K If your business depends on fast, reliable Internet or remote-access-server connections, find an x2-equipped Internet service provider and buy a 3Com Courier V.Everything 56K. It's definitely worth the price. **Company:** 3Com (408/764-5000, www.3com.com). **List price:** \$250.

PC Card Modem

Due to their disappointing performance, we can't recommend any PC Card modems. Stick with your 28.8 or 33.6 model, pack along a compact external 56K modem, or wait until the V.PCM standard is finalized.

REAL PRODUCTS REAL RATINGS

Reviews you can trust Macworld rates only final shipping products, not prototypes. What we review is what you can actually buy.

Matrox powers your Mac into the next Millennium

Matrox Millennium II - Superior performance for PCI Macs



Laying out that new ad. Putting together a cool video presentation. Or adding the finishing design touches to a web page. Time is money, and you need your Mac to do it all. Fast. The Matrox Millennium II graphics

accelerator for Mac delivers uncompromising performance for all your professional needs. Quark Xpress, Photoshop, illustrations, and Web designs can be scrolled, zoomed and loaded in a matter of seconds. Its powerful, dual-ported WRAM memory and 250 MHz RAMDAC process true color images with lightning speed. Upgradeable to 16 MB, Millennium II for Mac displays graphically intensive files at resolutions as high as 1920 x 1200 without missing a beat. What's more, with hardware accelerated Quick Draw 3D and a 32-bit Z buffer, you can bring 3D texture mapped graphics into your 2D design applications and manipulate them in real-time. Millennium II for Mac also offers accelerated MPEG1 video playback and support for QuickTime video - making it an ideal solution for watching computer based training videos, CD movies, and educational CD-ROM titles.

With over 300 awards of distinction, Matrox is the leader in designing state-of-the-art graphics accelerators. When choosing an upgrade for your Mac, choose a company you can rely on. Choose Matrox.

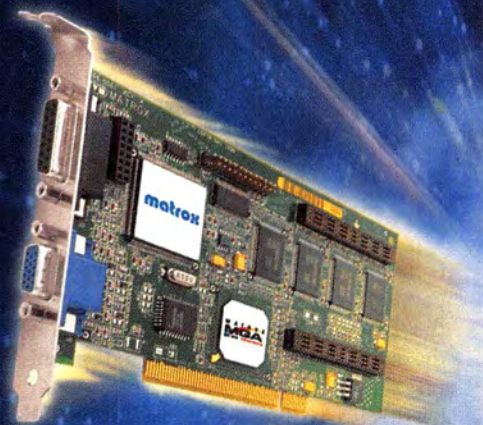

Matrox Millennium II for Mac

- Ideal for graphic designers and power users
- Upgradeable to 16 MB of WRAM

\$199 ESP (4 MB)

matrox

1-800-786-9836 <http://www.matrox.com/mga>

INGRAM
MICRO

1-800-456-8000



1-800-999-9382

Tech Data

1-800-237-8931



Circle 24 on reader service card

Secrets

The HFS+ Survival Guide

HOW TO GAIN INSTANT, FREE HARD-DISK SPACE WITH MAC OS 8.1

by Joseph Schorr

How would you like to expand your hard-disk storage capacity by hundreds of megabytes—without using a compression utility, installing a single system extension, or spending a dime?

You may be able to do just that if you're using Mac OS 8.1, which supports Apple's new Mac OS Extended Format, or HFS+. This new disk format replaces the aging Hierarchical File System (HFS), which Apple now refers to as Mac OS Standard Format. HFS+ greatly optimizes the storage capacity of your hard disks by making more-efficient use of hard-disk space (see "How HFS+ Saves Space").

This sounds too good to be true, but it really works. Reformat your current hard disk as an Extended Format disk, and when you're done, you'll find you've reclaimed an enormous amount of storage; all your files simply take up less disk space. Just how much space you reclaim in this process depends partly on the size of your disk—the larger the disk, the more space you stand to gain. You'll also reclaim more space if you have a large number of small files, rather than just a few enormous files.

HFS+ is one of the most meaningful improvements Apple has brought to the Mac in years. But don't rush out and start reinitializing your disks just yet. If you're not careful, you can end



up with plenty of hard-disk space but no way to access your files. Here are some pointers for upgrading to HFS+, and a few important warnings.

The Rules of HFS+

- The larger your hard disk, the more you can benefit from HFS+. On disks smaller than 1GB, the space-saving benefits aren't nearly as dramatic. For instance, you can format an 80MB disk with HFS+, but you won't gain even a megabyte; with a 1GB disk, you'll

probably gain well over 100 megs.

- You can't use an HFS+-formatted disk as the start-up disk in any 680X0 Mac. Only PowerPC-based Macs can start up from an HFS+ disk.

- Hard disks formatted with HFS+ can't be selected as virtual-memory disks (in the Memory control panel).

- You can't format floppy disks as HFS+ volumes.

- You can access HFS+ disks only from Macs running Mac OS 8.1. If you

continues

How HFS+ Saves Space

UNDER THE CREAKY OLD HIERARCHICAL FILE SYSTEM (HFS), INTRODUCED 12 years ago, every disk—floppy disk, hard disk, Jaz cartridge, whatever—is divided up into 65,536 equal-size blocks. These allocation blocks serve as the tiny “parking spaces” where the Mac stores individual chunks of data.

In the old days, when a 20MB hard disk seemed insanely huge, the 65,536 blocks mapped out onto each disk were indeed tiny. But as disks have grown, so have block sizes. When you divide 500MB into 65,536 blocks, the block size turns out to be 8K. On a 4GB disk, however, each block is 64K.

The result is a colossal waste of space. That's because even the smallest file on any disk has to occupy at least one block, the smallest disk storage unit that the Mac can understand. So a file containing 2K of data will use up an entire 64K (one block) on a 4GB disk, wasting nearly 97 percent of the storage capacity within that block. Likewise, a 70K file on the same disk will swallow up 128K, because the file requires at least two 64K blocks to contain it.

Under the new Mac OS Extended Format, HFS+, the maximum number of blocks allowed on a disk swells from 65,536 to 4.29 billion. That means that even huge disks can be formatted with much-smaller blocks—and smaller blocks mean less wasted space. For instance, on a 4GB disk formatted with HFS+, a file containing 4K of data will occupy no more than 4K of space.

try to mount an HFS+ disk on a Mac running an earlier system, all you'll see is one file: a Read Me document called *Where_have_all_my_files_gone?*, which explains how to upgrade to Mac OS 8.1. Macs running earlier system versions *can* access files on HFS+ disks over a network, however, as long as the server is running OS 8.1.

- You'll need to upgrade your current hard-disk tools and utilities; most of them won't work properly with HFS+—formatted disks. Keep an eye out for new versions of programs such as Symantec's Norton Utilities and MicroMat's TechTool, which are being updated to deal with problems on HFS+ volumes. FWB also plans to release an HFS+—compatible version of Hard Disk Toolkit.

Making the Switch

Converting a disk to HFS+ means completely reinitializing it, which involves erasing all the data on it. So the first step in the conversion process is to create a reliable backup of your entire hard disk. When you're done reinitializing your hard disk, you'll have to copy all your files back.

To reinitialize the disk, select it in the Finder and choose the Erase Disk command (obviously, the disk you're reinitializing can't be your current start-up disk). In the Erase Disk window, choose Mac OS Extended from the Format pop-up menu. Alternatively, you can use Apple's Drive Setup utility (version 1.4 or later), which gives you more options than the Erase Disk command does. First click on Initialize, then click on Custom Setup and choose Mac OS Extended (HFS+) from the Type pop-up menu (see “Extend Yourself”).

There's also at least one way to convert to Extended format *without* reinitializing your hard disk: use PlusMaker, by AlSoft (281-353-4090, www.alsoftinc.com), a \$19.95 utility that converts your existing HFS disks into Extended-format volumes without reformatting them, leaving your data intact. PlusMaker can create allocation blocks as small as 0.5K in size—the smallest possible under HFS+—and converts disks faster than Drive Setup can. Because it doesn't reformat your disk, you don't need to recopy your files after you use it. It's still a good idea to backup your data first, though.

Best of Both Worlds

Remember, if you reformat a removable or an external hard disk with HFS+, your files will be inaccessible from any Mac running a system earlier than version 8.1. But there is a way to make sure you never find yourself unable to access your files when you connect your drive to another Mac: When setting up your HFS+ disk with Drive Setup, create *two* partitions—one large Extended Format (HFS+) partition for all your data, and one tiny Standard Format (HFS) partition. Then install a Mac OS 8.1 System Folder on the small HFS partition. To waste as little space as possible, use the System Folder from the

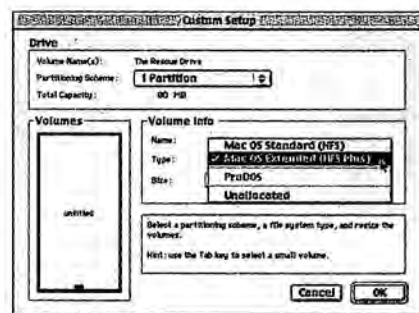
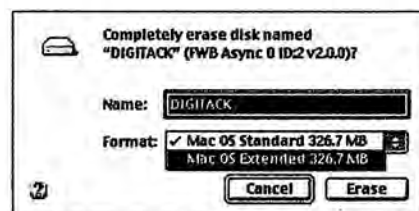

Extend Yourself To format a disk with HFS+, choose Mac OS Extended when using the Erase Disk command (top) or when using Apple's Drive Setup utility (bottom).

Mac OS 8.1 Disk Tools package, which includes a scaled-down version of OS 8.1 that fits on a single floppy disk. (You have to create the two 8.1 Disk Tools disks yourself, using DiskCopy; the disk images are included on the Mac OS 8.1 CD. Look in the Disk Tools Images folder.)

With this double-partitioned setup, you'll always have a copy of 8.1 at your disposal—without wasting more than a few megabytes of storage space. If you attach your drive to a Mac that can't access your HFS+ volume, just reboot from the HFS partition and you'll have full access to all your files. **m**

JOSEPH SCHORR is coauthor of the forthcoming *Macworld Mac Secrets*, fifth edition (IDG Books Worldwide, 1998).

PLAY TO WIN CASINO™

AUTHENTIC VEGAS GAMEPLAY. THE BEST STRATEGIES, TIPS & TRICKS.



ROULETTE



SLOTS



VIDEO KENO



CRAPS



BLACKJACK



VIDEO POKER

LEARN AS YOU PLAY,
NOT AS YOU PAY

- Fast, responsive, highly-realistic casino action
- Tips & tricks integrated into every game
- Optional step-by-step instructions for beginners and advanced strategies for experts
- On-the-fly expert advice. Ask the computer what to do
- Optional warning system alerts you to high-risk bets
- Game and Wager Summaries let you analyze your playing habits
- Complete glossaries and on-line help

Available at Retailers Everywhere!
800-229-2714

Call for a free catalog or visit our website at www.wizworks.com

System Requirements: Any Macintosh running system 7.0 or higher with at least 4MB RAM, CD-ROM drive and 256-color monitor (thousands of colors recommended)
©1997 Varcon Systems, Inc.



Circle 30 on reader service card

MacSoft®

An affiliate of GT Interactive Software Corporation
2300 Berkshire Lane No., Plymouth, MN 55441 • 612-509-7600
Call for a free catalog or visit our website at www.wizworks.com

24"



15 ft.

11"



17"

Maybe it's time you broke out of that 11 x 17 world.

Creatively speaking, nobody likes to work in a box. But if you're still using conventional desktop printers, that's precisely what you're doing.

Croma24™ from ENCAD® can take your ideas much further. It's a versatile inkjet printer capable of producing photo-realistic images in vivid color at widths of up to



24 inches, and lengths of up to 15 feet. A fact that should have you salivating at the possibilities.

Because now, design firms can easily create packaging prototypes. Ad agencies can produce full-size storyboards without tiling. And corporate types everywhere can make the big presentation exactly that.

ENCAD Croma24 is easy to operate. It's Mac and PC

compatible. And it'll help save time and money by minimizing your reliance on outside service bureaus.

And, ENCAD Croma24 starts at **\$2,395**. So you can unleash your creativity while still pleasing the folks in Accounting. For more product information, visit our web site at www.encad.com. Or call 1-800-45 ENCAD for your nearest Authorized Reseller. Then watch your imagination truly soar.

Circle 65 on reader service card



ENCAD

© 1998 ENCAD and Croma24 are trademarks of ENCAD, Inc.

Tips, Tricks, and Shortcuts

by Lon Poole

You don't have to restart your computer to implement a new system font chosen from Mac OS 8's Appearance control panel, according to Chris Dreesen of Danville, California. Chris points out that if you hold down the option key while selecting a font, the change occurs immediately. You can install nonstandard fonts—such as the freeware font Virtue and shareware font Nu Sans-Bold, by Marty Pfeiffer, and the Tecton and Veritas fonts from Greg Landweber's Kaleidoscope shareware—by using ResEdit to modify the sfn# resource ID 0 as described in "More System Fonts," *Quick Tips*, January 1998.

Getting More Drive

Q. How do I add an internal hard drive to my Mac's expansion bay? Is it just a matter of changing the new hard drive's SCSI ID and making sure that the drive's SCSI port is compatible with the Mac's SCSI cable? Will the hard drive automatically mount?

NYANISO RAHOTEP
Atlanta, Georgia

A. All Macintoshes use the same type of ribbon cable and connector for internal SCSI connections (and the same power connector too), so there's no risk of that kind of incompatibility. But Macs don't all accept the same type of mounting bracket, so make sure that the drive you buy comes with the correct mounting bracket for your make and model of Macintosh.

Before installing the new drive, you may need to change its SCSI ID so it

doesn't conflict with other internal SCSI devices. A factory-installed SCSI internal hard drive uses ID 0, and an internal SCSI CD-ROM uses ID 3.

Also make sure the new drive's SCSI ID doesn't conflict with the IDs of any external SCSI devices connected to your Mac. (This isn't a concern if your Mac has a separate external SCSI bus, found in computers such as the Quadra 900 and 950; Power Mac 7300, 7500, 7600, 8100, 8500, 8600, 9500, 9600, and G3; DayStar

the drive to the mounting bracket that comes with it. Then remove your Mac's case and note the location of the SCSI ribbon-cable connector and the power plug near the back of the expansion bay. Install the drive-and-bracket assembly in the expansion bay, and plug the computer's spare SCSI and power connectors into the drive. Then put your Mac's cover back on. When you start up your Mac, the new disk's icon will automatically appear on the desktop.

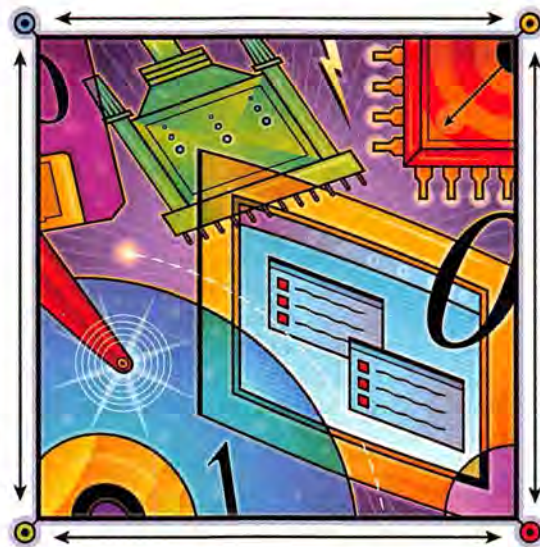

Digital Genesis LT and Genesis MP; Power Computing PowerTower Pro and PowerWave; and Umax SuperMac J700 and SuperMac S900.)

You may also need to configure the new internal drive's SCSI termination. Only your Macintosh's original internal SCSI drive should have built-in termination. (IDE and ATA drives do not have SCSI IDs or termination.) Check the drive's documentation for detailed instructions on configuring its SCSI ID and termination.

After ascertaining your new SCSI drive's ID and built-in termination, attach

Banish an Unruly Folder

Q. A former America Online folder has defeated all classical attempts to be removed, including strategies such as holding down the option key while emptying the Trash, restarting with extensions off, renaming the folder, replacing the folder with another folder of the same name, and installing new system software.

If I try to put anything inside of the folder, the Finder says the folder cannot be found. When I move the folder

to the Trash, the Finder reports an Error Type -127 but still moves the folder. When I try to empty the Trash, I get a warning that the folder can't be deleted because it contains items that are in use—but the folder is zero kilobytes in size. Any ideas?

J. ROY NELSON
Pennington, New Jersey

A. Error Type -127 is an internal file system error and usually indicates a corrupted disk directory. Your other symptoms corroborate this diagnosis.
continues

You may be able to fix the problem with Disk First Aid (which comes with System 7.0 and later) or the Norton Disk Doctor component of Norton Utilities, from Symantec (408/253-9600, www.symantec.com).

If neither helps zap your belligerent folder, you'll probably have to initialize (erase) or reformat the hard disk. But don't forget to carefully back up the disk's contents before erasing or reformatting!

Trace URL Routes

Q I'm looking for a quick and easy way of seeing the route that my URL request takes to find its destination. I've learned that Windows NT has a command called "tracert" (trace route), which displays the path taken (as a listing of networks) from your computer to a particular URL. How can I do this on my Mac?

MARK KLITZKE
Methuen, Massachusetts

A There are several ways on the Mac to learn the names of the machines your request passes through to reach a specified URL or IP address (useful for troubleshooting a slow connection to a particular IP address or comparing the efficiency of different ISPs). You can get this information from the \$10 shareware Mac TCP Watcher 2.0, by Peter Lewis, or the freeware WhatRoute, by Bryan Christianson. Your Mac must be using Open Transport 1.1 or later to get route information with these utilities.

Mac TCP Watcher can also test whether your Mac's TCP/IP setup and Internet connection are functional, and it can test the DNS (domain name system), which is the Internet service that converts server names to numeric IP addresses such as 205.199.66.216. These features don't require Open Transport, as they also work with classic networking schemes. (Your Macintosh uses Open Transport if it has a TCP/IP control panel, or classic networking schemes if it has a Mac TCP control panel.)

Preserving EMailer Address Groups

TIP If you've ever had to export your Address Book from Claris EMailer 2, you know that you can't export address groups, only individual addresses.

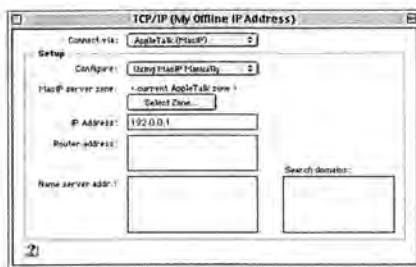

Faking an Offline IP Address To preview your Claris FileMaker Pro 4.0 database in a Web browser while not connected to the Web, create a new configuration in the TCP/IP control panel and set its Connect Via, Configure, and IP Address options as shown here (leave all other options blank). The IP address becomes part of the URL for your FileMaker Web site—in this example, <http://192.0.0.1>.

But if you want to load a copy of your Address Book onto your PowerBook, for example, a slick workaround will save you the hassle of re-creating address groups from scratch—and will also let you easily share address groups with fellow EMailer users. All you need is Macintosh drag and drop, which is built into System 7.5 and later.

First, open the EMailer Address Book window and drag an address group from the window to the desktop. This creates a text-clipping file that contains every address in the group, each formatted as *mailto: "Quick Tips" quicktips@macworld.com*, for example.

To re-create the group, simply drag the text-clipping file into the address area of EMailer's Address Book window. Voilà! EMailer automatically creates a new group containing all of the addresses from the clipping file. Just type in a group name and you're done.

TROY S. CURTIS
Phoenix, Arizona

No-Charge Database Previews

TIP If you want to use Claris FileMaker Pro 4.0's Web Companion features to publish a database on the Web and you have a dial-up Internet connection, you can preview your database in a Web browser without connecting to the Internet and adding charges to your dial-up account. All you need to do is fool TCP/IP into thinking you have been supplied with an IP address.

Open the TCP/IP control panel, choose the Configurations command from the File menu, and make a duplicate

of your default configuration in the Configurations dialog box. Click the Make Active button with the duplicate selected. Then set up the TCP/IP options for the duplicate as shown in "Faking an Offline IP Address." Next, use FileMaker Pro 4.0's Sharing command to privately publish your database with your new faked offline IP address. Turn on the Sharing command's Web Companion option. (If the Web Companion option was already on when you changed the TCP/IP configuration, quit FileMaker and reopen it so that it uses your new faked offline IP address.)

Now you can view your database in Netscape Navigator or Microsoft Internet Explorer by specifying the URL <http://192.0.0.1> (this is the IP address you specified in the TCP/IP control panel).

When you're ready to publish your database on the Internet, quit FileMaker and open your TCP/IP control panel. Call up the Configurations dialog box again as before, select your regular default configuration, and click Make Active. Then connect to the Internet (using the PPP or Config PPP control panel, for example) and reopen the FileMaker database you want to publish. Look in your TCP/IP control panel for the IP address people must specify in the URL (of the form <http://206.14.59.41>, for instance) to get to your database site.

Now when your Mac is connected to the Internet, anyone can use a Web browser to access your database.

TONY FALLA
North Fitzroy, Victoria, Australia

Access Eudora Remotely

TIP Do you want to access your Qualcomm Eudora mailbox from a remote Mac over a network? First, turn on file sharing on the Mac with your Eudora mailbox, using either the File Sharing or Sharing Setup control panel. Then select the Eudora Folder inside that Mac's System Folder and choose Sharing from the File menu to access the Eudora Folder's sharing-options window. In this window, select the option Share This Item And Its Contents and set the access privileges to prohibit access by Everyone (that is, by guests).

Now you can access your shared Eudora Folder from a remote Mac on the

continues

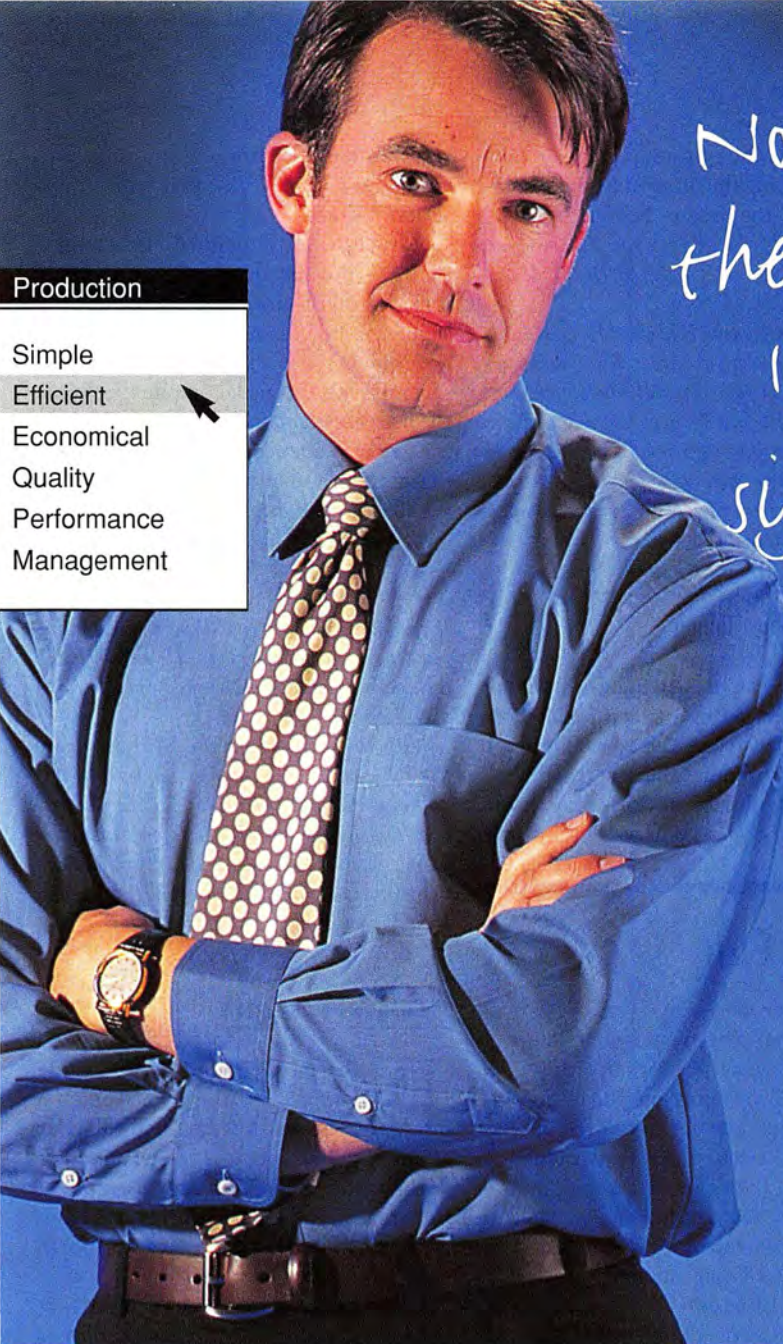

No matter what
the deadline,
I need client
sign-off before
I buy film

- Production
- Simple
- Efficient 
- Economical
- Quality
- Performance
- Management



No problem. Using the HP DesignJet 455CA printer your Mac artwork and photo images are checked easily - saving time and film costs. The HP printer gives you vivid images and crisp fonts, producing a high-quality 24" x 36" color print onto sheet or roll-feed paper in just 18 minutes*.

Clients will love the fast turnaround and extra productivity your big in-house inkjet printer can deliver ...
... and you won't be disappointed either!

HP DesignJet 455CA

Large-Format Printer
Designed by designers for designers

\$3,195** (24" wide) \$4,195** (36" wide)

Call 1-800-851-1170 for more information or visit
www.hp.com/go/designjet/455

*Printing in normal mode.
The HP DesignJet 455CA printer includes PostScript Level 2 language-compatible print and color management RIP software for Mac, roll-feed and auto cutter.
Legs and media bin are an optional extra.
**US list price.



Circle 11 on reader service card

network—including a Mac connected to the network via modem and Apple Remote Access software.

Connect to your original Mac, and access its shared Eudora Folder by using the remote Mac's Chooser. Make an alias for the Eudora Folder icon that appears on the remote Mac's desktop, and put the alias in that Mac's System Folder. Open the System Folder, drag the remote Mac's original Eudora Folder onto the desktop (or into the Trash if no one will need to use its mailboxes and address book), and change the name of the Eudora Folder alias to Eudora Folder.

Now when you launch Eudora on the remote Mac, the Mac uses the Eudora Folder alias to access the Eudora Folder on your original Mac. You can access your mailboxes, queue messages, and so forth across the network.

If you need to restore the remote Mac's local mailboxes and address book, just drag the Eudora Folder alias from

the remote Mac's System Folder to the Trash, and drag the original Eudora Folder back into the System Folder.

CLEMENT TOPPING
Montreal, Quebec, Canada

The files in the Eudora Folder can be opened only by one copy of Eudora at a time, so you can't leave Eudora open on your original Mac if you want to access the Eudora Folder over the network. While working from a remote Mac, it's a good idea to save new messages and changes to your address book often, in case the network connection breaks unexpectedly.—L.P.

Vary Slide-Show Timing

TIP You can display images at varied intervals in a timed slide show without expensive presentation software—and even without the macro/shareware solution suggested in “Slipping Slide Show” (*Help Folder*, January 1998). A very

simple method works in any program, including ClarisWorks, that will show a series of slides.

To show an individual slide longer than the normal specified interval, just include two or more of the same slide in sequence. For example, if the slide show program is set to advance slides every 30 seconds, you can make one image visible for 60 seconds by including two identical images in sequence. The only limitation of this method is the extra disk space required by the duplicate slides.

ROBERT WRIGHT
Bryn Mawr, Pennsylvania

If your software can layer slides, you can minimize the extra disk space needed by adding blank transparent slides after the slide you want displayed longer.

Another solution is the \$15 shareware View Finder, from Autumn Software (www.autumnsoft.com). It lets you combine pictures, text, QuickTime MIDI, voice-over, and other sounds into an automated slide show. You can use transitions, and you can specify how long View Finder displays each image.—L.P.

You Can See Clearly Now

TIP To save wear and tear on cable connectors and ports, attach a mirrored tile to the wall behind your computer. This lets you see what you're doing while connecting and disconnecting cables, and saves you from having to move your computer back and forth while doing so.

AL HART
Clinton, Michigan

LON POOLE answers readers' questions and selects reader-submitted tips for this monthly column. His latest book is *Macworld Mac OS 8 Bible* (IDG Books Worldwide, 1997).

Shareware mentioned in *Quick Tips* is available from Macworld Online (www.macworld.com) or America Online (keyword Macworld; use keyword Apple for Apple software).

We pay \$25 to \$100 for tips on how to use Macs, peripherals, or software. Please include your full name and address, so that we can send you your payment. Send questions or tips to quicktips@macworld.com or to Macworld Quick Tips, 501 Second St., San Francisco, CA 94107. All published submissions become the sole property of *Macworld*. Due to the high volume of mail received, we cannot provide personal responses. **m**

A Little April Fool's Fun

For a practical joke the Three Stooges would appreciate, invert the screen image on the Mac of an unsuspecting friend. If the victim's Mac has Adobe Photoshop, you can pull this prank with the method sent in by Joseph Holmes of Kensington, California.

First, wait until your victim goes for coffee. Then sneak over to the person's Mac and make a screen shot of the

current screen image by pressing ⌘-shift-3. Open the screen-shot file (which will have a name such as Picture 1 or Picture 2) in Photoshop, and rotate the canvas 180 degrees. Zoom to 100 percent, and select the full-screen display mode in the lower right corner of the Photoshop tool bar. To complete the effect, hit the tab key to hide the Photoshop tool bar and any open Photoshop palettes. Leave Photoshop open, and scurry away before your victim returns.

You'll need at least a solid minute or two at the victim's computer to pull this off, so practice on your machine beforehand to cut down on lag time.

After setting up this gag, lurk nearby and witness the payoff. When you hear the satisfying “What the . . . ?!” let loose with a Curly-esque “Nyuk, nyuk, nyuk”—but be prepared to fend off a Moe-esque two-finger eye poke.



The Old Upside-Down-Screen Gag No, we didn't print this screen shot upside down. (Look closely at the tool bar for proof.) With a little work in Adobe Photoshop, you can freak out your favorite Macaholic on April 1 by inverting the person's screen image.

Introducing SuperClear.™
A monitor with an image so clear
we had to trademark it.



SuperClear.™ It's the latest advancement in screen performance and, not surprisingly, it comes from ViewSonic®, the biggest company in Display Technology™ and the leader in the 17" (various viewable) market.

The focus is on clarity.

The .26mm dot pitch G773 17" (16.0" viewable) monitor sets new standards for image clarity. The reason is our SuperClear Screen—ViewSonic's latest engineering breakthrough. It combines the exceptional focus found in high contrast conventional CRTs and the superior colors found in aperture grille CRT monitors. The result: Absolutely the clearest, brightest images and most vivid colors available on a 17" (various viewable) monitor. At any price. Period.

Easy on the eyes.
Easy on the environment.

 The G773, with 1,024 x 768 resolution at 87Hz, is the perfect choice for home office, students and surfing the Internet. And, in keeping with ViewSonic's commitment to environmental concerns, the G773 meets strict TCO '95 standards which reduce heat emissions, lower power consumption and mandate the use of recyclable parts.

Model	G773
CRT Screen Size	17" (16.0" viewable)
Dot Pitch	0.26mm
Maximum Resolution	1,280 x 1,024
Recommended Resolution	1,024 x 768 @ 87Hz

Compliance to this TCO certification insures that ViewSonic monitors are environmentally and ecologically friendly as well as user friendly.

To fully appreciate the clear advantages of the G773 though, you really need to see it in person.

For the dealer nearest you, call ViewSonic at (800) 888-8583 ask for agent 81177, or visit our website at: www.viewsonic.com.



(909) 869-7976 Fax: (909) 869-7958 • Internet: www.viewsonic.com • Specifications subject to change without notice.
 Copyright © 1997, ViewSonic Corporation, all rights reserved. • Corporate names and trademarks stated herein are the property of their respective companies.

11:00



11:06

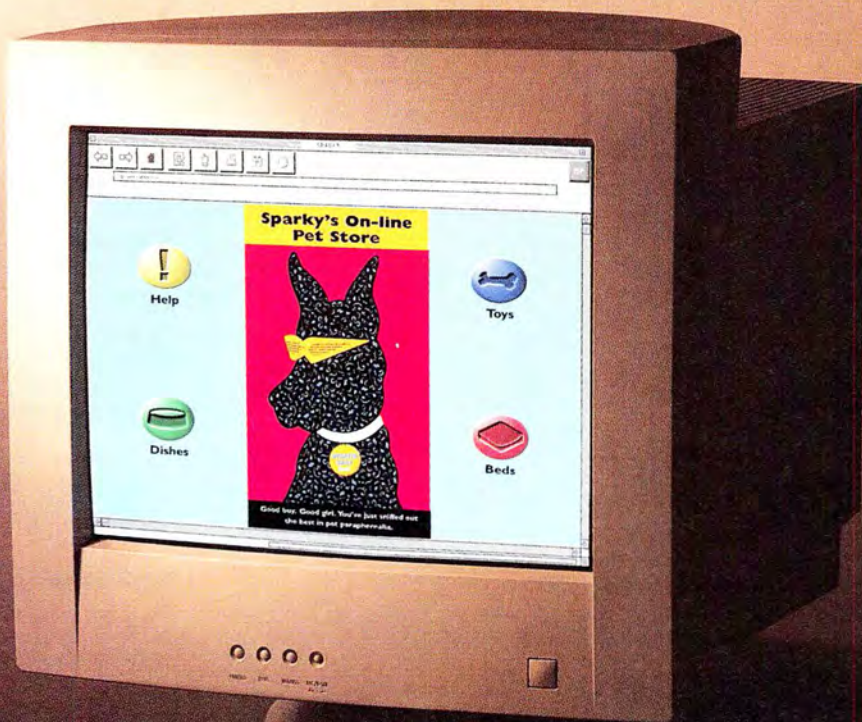

**Care to see
that again?**

Considering how time-consuming cross-media publishing can be, you may not believe the speed of Adobe PageMaker® 6.5 Software. Fast, easy, intuitive. From paper to HTML. To Acrobat PDF. To CD. It runs across media like a puppy across a playground. End result, you fetch more results, contracts, profits. So go ahead. Blow your dog whistle and call us today at 1-800-422-3623 or www.adobe.com.



Spot Color and Photoshop—Oil and Water?

Tricks to Make Photoshop and Spot Color Mix

by David Blatner and Sandee Cohen

Out of all the Adobe Photoshop questions we've been asked over the years, we get one more than any other: "How do I get a true Pantone spot color in Photoshop?" The awful truth is that you can't use a spot color in Photoshop to paint or fill an area. But that doesn't mean you can't get Photoshop to give you what you want. In this article, we'll show you a couple of workarounds that trick Photoshop into giving you spot color. First, it's important to know how spot colors are different from process colors and why Photoshop has trouble with them.

Spot Color versus Process Color

Process color lets you simulate a color by overlaying varying tints of cyan, magenta, yellow, and black. Look with a magnifying glass at any color magazine image, and you'll see that there are only four colors in it, each printed with tiny halftone spots.

Spot colors (such as Pantone colors) are inks that exactly match a particular color. For instance, if your company logo requires black plus a single color, it's best to print with black ink and a spot color. It would be silly to print with four inks just to get one color. Also, there are some colors—such as electric blue and bright gold—that just can't be simulated with process colors. Most two- or three-color jobs are printed with spot colors. Spot color would not be appropriate, however, for most full-color jobs—you'd go crazy trying to mix thousands of inks for tiny parts of an image.

How Photoshop Handles Color

When it comes to describing color in Photoshop, spot colors get short shrift. You can easily describe RGB and CMYK colors in Photoshop, because behind the scenes each pixel is broken down into so much cyan, so much magenta, and so on. But there's no way to tell Photoshop that your image is CMYK *plus* a spot color, such as Pantone 286.

When you select a Pantone color in Photoshop's color picker, you don't get a true spot color. You get an RGB or CMYK representation of that color (depending on the mode of your image). When you print

separations of the color image, even though you'll want the Pantone color to show up on its own piece of film, it won't. It'll separate out into process colors.

The only time Photoshop gets spot colors right is when you're building a duotone (see "Add Richness with Spot-Color Multitones"), but duotones aren't useful for logos, two-color illustrations, and most other jobs that require spot colors.

The Channel Trick

Fortunately, there are a couple of methods for tricking Photoshop into working

continues

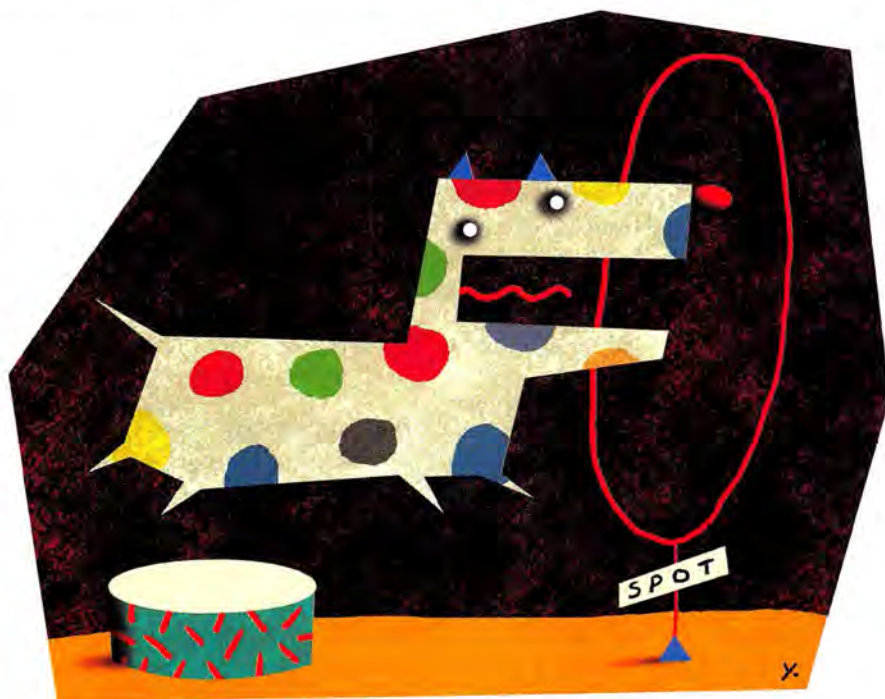

with spot colors. The most common technique is to create a new channel in the Channels palette. To do so, follow these steps:

1. Option-click on the New Channel button in the Channels palette.

2. In the Channel Options dialog box, choose the spot color you want (click on the color swatch). This is for preview only, so you can pick any color that's close to the one you're aiming for.

3. Change the Opacity field to 85 percent. The exact amount is unimportant—since this step is also only for preview use—but 85 percent tends to simulate the opacity of a spot color reasonably well.

4. Change the name of the channel to the name of the spot color.

5. Select this new channel to paint on (it should be selected automatically when you click on OK), and then click in the eyeball column of the composite-color channel (the one labeled RGB or CMYK).

Now, when you paint on this channel (but not the other channels), it will appear as though you're painting in the spot color. This trick has gotten us out of all kinds of spot-color jams, but there are a few things you need to watch out for when using it.

First, the screen doesn't show you a good preview of how the color will look or how it will interact with the other colors on the page. So knowing this spot color's characteristics—such as how opaque it tends to be—will make it easier to translate what's on screen into what comes off the press.

Next, you have to use a Photoshop plug-in to separate these images correctly. Two plug-ins that do this are Platemaker (\$199, from a lowly apprentice production) and Channel/24 (the only way to get it is with the \$350 MC-P/Co-Co, a plug-in we discuss later). These plug-ins save the image in a DCS 2.0 format that can be opened in and printed from QuarkXPress or PageMaker.

The third problem is that if your spot colors overlap with any other colors, you must manually "knock out" the background colors by deleting them from those areas (unless you want the spot color to overprint the background colors).

If you're using spot colors as bump plates or varnishes, you owe it to yourself to check out the MC-P/Co-Co plug-in (from Visu Technologies and distributed by Pantone). It's expensive,

Add Richness with Spot-Color Multitones

THE ONLY PHOTOSHOP FEATURE THAT SAVES SPOT COLORS CORRECTLY (ON THEIR own plates) is Duotones. Historically, printers have coaxed more depth and detail out of gray-scale images by printing them not only with black but also with two, three, or even four spot colors (you can use process colors, too). These images are called duotones, tritones, or quad-tones (the collective word is *multitones*). The effect isn't meant to colorize the image, although some designers use it for this purpose (often with ugly results).



Original gray-scale image



Tritone image

Converting to Multitone

You can turn a gray-scale image into a multitone in Photoshop by choosing Duotones from the Mode submenu (on the Image menu). Next, load one of the settings that comes with Photoshop (click on Load, and navigate to the Duotone Presets folder, which is inside the Goodies folder in the Photoshop folder). You can try to create your own set of curves, but it's deceptively difficult to get a good-looking image.

There are three different types of presets: Grays, Pantones, and Process Multitones. Choose one of the first two if you're printing with spot colors. Choose the third if you're printing with process colors. Even if you aren't using exactly the same color inks as the ones in the presets, these curves will provide an excellent jumping-off point. Just find a set with colors similar to the inks you're using. You can change the color and tone curve later (just don't change them much).

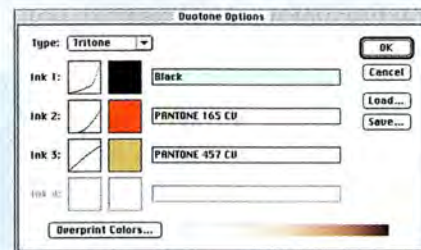

Click on a color box to change the color

Click on a curve to view or change the curve

Click on Load to load a set of curves and colors from disk

but if you do a lot of this sort of work, you'll find that it pays for itself.

The CMYK Trick

Another method for creating spot colors in Photoshop is to use the cyan, magenta, yellow, and black channels as spot-color channels. For instance, if you're creating a two-color image with black and a burgundy spot color, you could put the black on the black plate and the burgundy on the magenta plate. When you bring your separations on film to your

print shop, you'll need to specify that the magenta plate is actually supposed to be printed in the Pantone color you want. (It's a good idea to write the Pantone color on the film itself, just in case.)

The problem here, of course, is that the screen preview is completely wrong. Fortunately, you can change the way Photoshop defines its process colors, in the Printing Inks Setup dialog box. If you redefine magenta as the Pantone burgundy you're using, the screen preview will be much closer to the final out-

Dissecting a Multitone Curve

Photoshop builds multitone by applying a series of tonal curves (one per ink). Analyzing curves helps you understand the principles behind multitone. To see how, let's look at a tritone made of black, Pantone 165, and Pantone 457 (because our magazine is printed with process colors, we have to simulate the spot colors here).

Black Ink This curve suppresses almost all the black in the highlights and midtones. But the shadows have a normal amount of black. This lets the other colors hold the image in the highlights and midtones but gives the image good details in the shadows.

Pantone 165 This curve suppresses almost all the detail in the highlights but boosts color in the midtones and shadows.

Pantone 457 In this curve, the light-brown/green Pantone carries most of the detail in the highlights and midtones but is only partially present in the shadows. Both the orange and the brown/green are suppressed at the 100 percent mark, avoiding ink buildup in the deep shadows while maintaining a rich black.

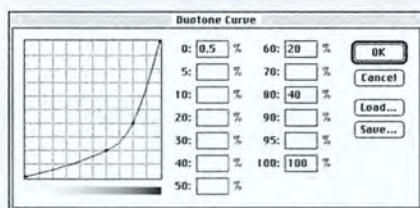

Black ink

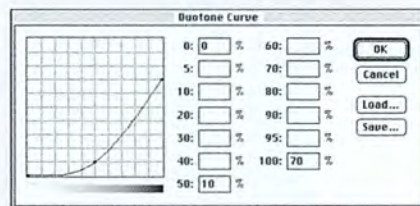

Pantone 165

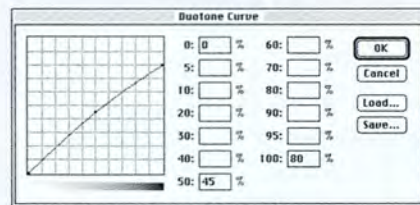

Pantone 457

Viewing the Plates

It's helpful to be able to see each spot-color plate individually, as you can in the RGB and CMYK modes. Unfortunately, that's not possible in the Duotone mode. However, if you convert the multitone to Multichannel mode (on the Mode submenu), you can see each ink on its own channel (the first ink is the first channel, and so on). You cannot perform adjustments to the individual channels, since there is no way to assemble them back into the Duotone mode, so this is just for viewing a preview. When you're done looking, select Undo (⌘-Z) to return to the Duotone mode.



Black plate



Pantone 165 plate



Pantone 457 plate

Saving Duotones

Note that in order to print your duotone from QuarkXPress or PageMaker properly, you must save it out of Photoshop as an EPS file. Then, in the page-layout program, make sure the spot colors you're using are in your color list (the names must be identical). The spot colors are usually created for you when you import the EPS file (just don't delete them).

put. (Don't forget to change the Printing Inks Setup back to SWOP or whatever ink setting you're using, before trying to do color separations.)

Spot-Color Futures

Someday the folks at Adobe are going to wake up from their process-color dreams and realize that tens of thousands of their Photoshop users use spot color every day. We look forward to a time when these workarounds are no longer necessary for something as simple as creating text in a

spot color or building a spot-color logo in Photoshop. In the meantime these workarounds can help you squeeze quality spot-color artwork out of Photoshop. **m**

DAVID BLATNER is the coauthor of *Real World Photoshop 4* (1997, Peachpit Press) and *The QuarkXPress 4 Book* (1998, Peachpit Press). You can contact him at david@moo.com. SANDEE COHEN is a New York-based desktop-publishing trainer and consultant and the author of two *Visual Quickstart Guides* for Peachpit Press. You can contact her at sandee@aol.com.

Bookmarks

Channel/24
A plug-in from Visu Technologies/Pantone
www.pantone.com

Platemaker
A plug-in from a lowly apprentice productions
www.alap.com

Second Glance
Makers of spot-color plug-ins
www.secondglance.com

Spot Process
Plug-ins for high-end silk-screening
www.spotprocess.com

Spot Color and QuarkXPress 4

Make Two Colors Look Like a Full Array

by David Blatner

Have you ever noticed that the people who yell the loudest for a new technology are the ones who stand to make the most money from it? For example, the print industry can become positively apoplectic when expounding on the glories of six- or seven-color printing on high-end waterless presses. Unfortunately, their hype often drowns out the simple truth that the majority of us can't afford such extravagance and must settle for down-to-earth two- or three-color print jobs instead.

However, just because you're printing with two colors doesn't mean that your finished piece has to look as if you've used only two colors. Just as you can mix process colors (cyan, magenta, yellow, and black) together to make thousands of other colors, you can add a medley of colors to your pages by combining spot colors. (For more information on spot versus process colors, see "Spot Color and Photoshop—Oil and Water?" elsewhere in this issue.)

For instance, if you use red and black inks in your document, it's easy to print light reds by tinting the red ink. Why not use dark reds, too, by mixing red and black together? If you're printing with red and blue, why not add purple to your pages by combining the two inks? By changing the tints of each ink, you can make many different shades of a color.

Here's how QuarkXPress 4 lets you make those shades.

And to help make sure your print jobs go smoothly, I offer some tips on avoiding some common mistakes.

Troubles Behind

In the past, the only reasonable way to mix spot colors together was to overprint two

objects—set one object to one color and then set the other object to a second color. This was not only cumbersome, but it also meant that you couldn't preview the final color on-screen or on most color printers. Fortunately, QuarkXPress 4 has taken a

quantum leap in mixing spot colors, with its introduction of Multi-Inks.

Multi-Inks are a new ink model in XPress, much like CMYK or RGB. However, instead of choosing combinations of process colors or red, green, and blue, you specify a

Building a Multi-Ink Color

Multi-Ink colors are mixtures of other colors. Here are a few tips to help you build them.

Before you can make a Pantone color part of a Multi-Ink color, you first have to create the Pantone color.

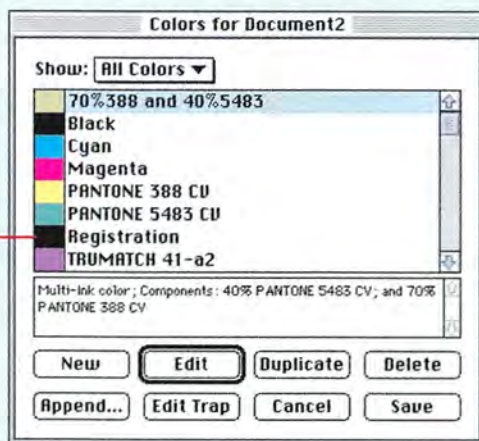

TIP To compare the makeup of two colors, first ⌘-click on them. Then hold down the option key and press on the Compare key that appears.

Choose Colors from the Edit menu or ⌘-click on a color in the Colors palette to open the Colors dialog box. Then click on New to create a new color.

Name the color here.

If you're printing with Hexachrome inks, choose Hexachrome from this pop-up menu. Otherwise, leave it alone.

Choose Multi-Ink here.

These options are grayed out because Multi-Ink colors are neither process nor spot colors.

Click on a color and choose a tint from the Shade pop-up menu. (To apply the same tint to more than one color, ⌘-click on the colors first.)

Click on OK when you're finished building your color.

Multi-Ink color as a mixture of other colors in your color list. And because you can mix process and spot colors, a Multi-Ink might be 100 percent cyan plus 30 percent Pantone 110. Or 20 percent Pantone 265, 40 percent Pantone 226, and 10 percent black.

A Multi-Ink color appears in the Color palette just like any other color in XPress, so you can use it in your document easily. XPress displays on-screen an approximation of how the two (or more) colors will print together (but see "Swatch Books" for caveats).

When you print (with the Separations check box checked in the Print dialog box), each color in the Multi-Ink color will appear on its proper plate. In the example I gave earlier, the 20 percent Pantone 265 would be on the Pantone 265 plate, and so on. See "Screen-Angle Madness" for more information on printing Multi-Ink colors.

Note that no other high-end DTP program on the market as of this writing—including Adobe Illustrator and Macromedia FreeHand—is able to handle Multi-Ink colors. If you need to use mixtures of spot colors, or spot colors with process colors, you have to create them in XPress 4.

Ink Issues

When it comes to putting ink on paper, mixing spot colors

Swatch Books

You've probably learned by now that you should never trust a color you see on screen. Even with a calibrated monitor, you often get shifts between what you see and what you get. The trick is to use a swatch book of printed colors. Many people know about using swatch books for picking out combinations

of process colors but don't realize that Pantone also makes swatch books that show mixtures of its spot colors. It's got one called *Color+Black* and another titled *Color+Color* that displays combinations of two spot colors. When you build a Multi-Ink color based on a formula in a swatch book, you know what you're going to get. The example above is similar to a page in the *Color+Black* book.



Note: I couldn't talk *Macworld* into printing with spot-color inks just for this article, so this illustration is a process-color simulation of spot colors.

isn't always the same as mixing process colors. The consistency and opacity of spot-color inks are often different from those of process-color inks, because they are usually used for different types of jobs. Some spot-color inks are almost fully opaque, so printing them over another color is useless.

Fortunately, most spot-color inks are semitransparent these days, so unless your printer adds Opaque White ink to the ink mixture, combining them should work.

However, this is a topic worth discussing with your printer first.

Note that metallic inks not only are opaque but also tint extremely poorly. So, don't try to build Multi-Ink colors by using a Pantone ink such as gold, silver, or copper.

More Inks, More Colors

Sure, six-color print jobs with varnishes and Day-Glo colors are fun to do. And when you do get a fancy job with six colors, you can use XPress 4's Multi-Ink feature for those

pieces, too. But while the industry pundits shout about how Hi-Fi color will change the world, don't forget that you're not the only one whose bread is buttered with two- and three-color jobs and that the Multi-Ink model can help you make the most of those precious few inks. **m**

DAVID BLATNER is the author of *The QuarkXPress 4 Book*, fifth edition (Peachpit Press, 1998), and *The Joy of Pi* (Walker and Company, 1997). You can reach him at david@moo.com or at the Web site www.joyofpi.com.

Screen-Angle Madness

What happens when you print one tint over another if both tints use the same halftone frequency and angle? You get moiré patterns, of course. In order to avoid these ugly things, you have to use the proper angles, which are almost always either 45 or 60 degrees apart. For instance, if you're

mixing a blue and a red, you may want to set blue to 15 degrees and red to 75 degrees.

There are a few tricks to using the correct angles. First, you should set only very light colors to zero degrees (or 90 degrees, which is the same as zero), because the halftone screen is

the most obvious at this angle. That's why the color yellow is usually set to zero degrees in process-color printing. If you're printing a purple and a light gray, you might want to set purple to 45 degrees (which is the least obvious halftone angle) and the light gray to zero degrees.

NOTHING
COMES CLOSER
TO REALITY.



RASTEROPS[®]

	CRT size (viewable)	Dot pitch	Maximum resolution	MSRP
Mc 801 HR	21 inch (20")	22 mm (h) .16 mm (v)	1600 x 1200 @76 HZ	\$1,999
Mc 801	21 inch (20")	22 mm (h) .16 mm (v)	1600 x 1200 @71 HZ	\$1,749
Mc 7515	19 inch (18")	22 mm (h) .14 mm (v)	1600 x 1200 @75 HZ	\$1,149
Mc 6315	17 inch (15.9)	22 mm (h) .16 mm (v)	1280 x 1024 @78 HZ	\$749
Mc 6215	17 inch (15.9)	.28 mm	1152 x 870 @75 HZ	\$599

If you're looking for the best value in an award-winning, high performance monitor, follow Macworld's lead. Or PC World's. Or a host of others.

And check out the new Hitachis.

Our new 19" Mc 7515 is an excellent example. Compared to Sony's 20sell, it's an inch smaller, but the Sony costs 74% more for comparable specs and performance.

So if you want a monitor that your eyes can appreciate as much as your wallet, your choice is simple. Hitachi. Call for the full story and your nearest retailer. 800 441-4832.



CDW 800 800-4239 Club Mac 800 258-2622 DTP Direct 800 311-7079 Express Direct 800 925-6777 Mac Connection 800 800-2222 Mac Mall 800 222-2808 Mac Market 800 223-4622 Mac Warehouse 800 255-6227 Mac Zone 800 248-0800 PrePress Direct 800 443-6600

HITACHI-NSA, 200 Lowder Brook Drive, Westwood, MA 02090 TEL: 800 441-4832. Faxback: 800 555-8552. www.nsa-hitachi.com

Circle 74 on reader service card

HITACHI

Watch This: Streaming Video on Your Web Site

If You Know the Right Tricks, Video Is More Practical Than Ever

by Jim Heid

Getting video to play back on the Internet can be like trying to suck peanut butter through a straw. Video's bandwidth demands can overwhelm the narrow pipes that are phone lines and modems. Well, pass the Skippy, because advances in video-compression schemes and serving techniques are gradually making Web video practical, even for modem users. And on intranets, the picture is even brighter: local-area networks' (LAN's) wider pipes allow for video quality approaching that of CD-ROM-based movies. Many companies and schools now deliver training videos, lectures, and presentations over intranets.

One key to making Web video practical is streaming: serving clips in a way that lets users view the beginning of the movie while the rest of the clip downloads. Another key is preparing your source material with Web video's limitations in mind. And the third is compression—lowering a clip's bandwidth requirements to accommodate the speed of your delivery vehicle, be it a modem, a LAN, or anything in between.

If you've dallied with digital video, editing your own QuickTime movies with programs such as Adobe Premiere, it's time to start thinking about putting your efforts on the Web. Web video is easier and more economical than ever.

Technologies Worth Watching

There are several players in streaming video, but the ones to keep your eyes on are RealVideo, from RealNetworks, formerly Progressive Networks (206/674-2700, www.real.com), and VivoActive, from Vivo Software (781/899-8900, www.vivo.com). They're the most popular streaming-video technologies, and with good reason: each provides easy-to-use compression software, a variety of ways to deliver video to your visitors,

and video that looks surprisingly good.

The basic production process is the same for both technologies. You create video as you would for CDs or broadcast: digitizing scenes from videotape and then editing them into a finished QuickTime movie. Next, you compress that movie with encoder software. Finally, you stash the encoded movie on a server and create a Web page containing links to it.

To view video, your site's visitors need the right playback software. For RealVideo, that's RealNetworks' free RealPlayer or \$29.95 RealPlayer Plus (which has features for improving playback quality and buttons that let users jump to their favorite sites). RealPlayer and RealPlayer Plus are helper applications, but when installing either one, you also install a plug-in module for playing video that has been embedded into a page rather than simply linked to it.

For VivoActive video, your visitors can download the free VivoActive plug-in module or purchase the \$12.95 VivoActive PowerPlayer, a stand-alone helper application that provides additional features, such as a volume control and the ability to play movies at larger sizes.

Apple's QuickTime 3.0, in public beta testing at this writing and due to ship by the time you read this, also shows great promise for streaming video. Apple has built into QuickTime 3.0 a remarkable new compression technology called Sorenson Video, from Sorenson Vision (408/970-0696, www.s-vision.com). Sorenson Video compression enables QuickTime 3.0 to stream reasonably high-quality movies at modem speeds. QuickTime 3.0 also lets you create *multiple-data-rate* movies: ones containing more than one version of a movie, each compressed for a given connection speed. The new QuickTime browser plug-in automatically selects and downloads the appropriate version. To learn

continues

Buffering for Interruption-Free Playback

One key to streaming media is the process of buffering. The player software downloads part of the movie or sound file and stores it in memory before playing it. Think of a buffer as a container with pipes at top and bottom. The player fills the buffer from the top. Once the container is full, the player sends data on for playback from the bottom. Data keeps coming in as a clip plays. The "water level" may change, but there's always a supply of video or audio data.

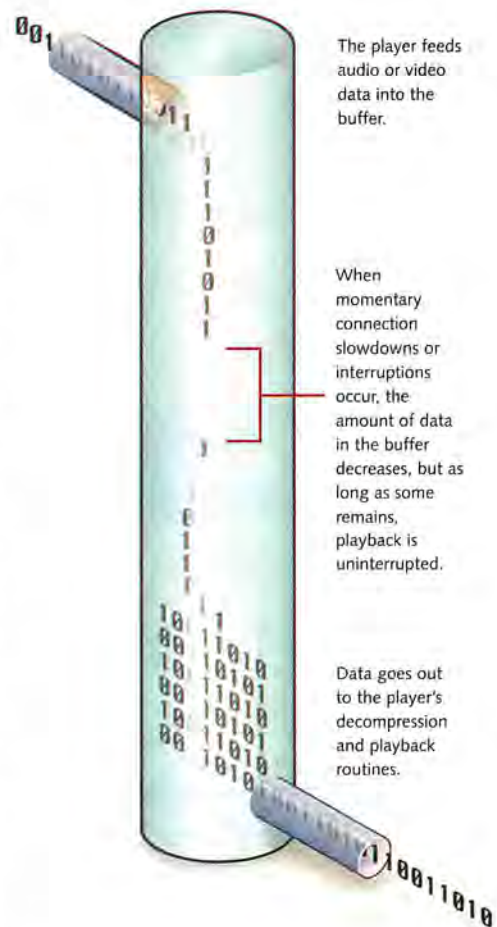

more about QuickTime 3.0's capabilities, see www.apple.com/quicktime/.

How Compression Kills Quality . . .

RealVideo and VivoActive rely on compression to reduce bandwidth requirements. Encoding a movie for streaming video is conceptually similar to compressing a movie for CD-ROM: both processes decrease the amount of data in the movie through temporal compression (removing information that stays the same from one frame to the next; say, a stationary object) and spatial compression (removing redundant information within each frame; for example, the many pixels with identical colors in a blue sky).

There is one big difference: transfer

rates for CD-ROM drives are much faster than those for the Internet or even most LANs. So Internet-destined movies need smaller frame sizes and slower frame rates than their CD-based cousins. While a CD-based movie might have 320-by-240-pixel frames and a rate of 15 frames per second, a RealVideo or VivoActive movie might measure just 160 by 120 pixels and have a frame rate of between 3 and 5 fps.

. . . And What You Can Do about It

Shoot and edit with the Internet's limitations in mind, and your final product will look better and play more smoothly.

Minimize motion. The more movement you have from one video

frame to the next, the less those frames will compress. To decrease the amount of change between frames, use a tripod and minimize panning and zooming.

Decrease detail. Video of an actor in a plaid jacket standing before a city skyline is chunkier and fuzzier than video of an actor all in red standing before a blue wall. Large areas of solid color yield better spatial compression. Go for bright colors: yellow, light blue, red, pink. Dark colors generate more video noise, which compresses poorly.

Light your subject. Shadows are prone to video noise, so light your scenes well—avoid indoor shoots under existing room light. Shoot in the highest-quality format you can afford: Betacam, digital-

Inside Encoders

RealEncoder (left) and VivoActive Producer (right) work similarly. After you specify a QuickTime movie and the desired target bandwidth setting, each program compresses the video, lowering the frame rate and adjusting (read: degrading) image and sound quality to fit within your target bandwidth.

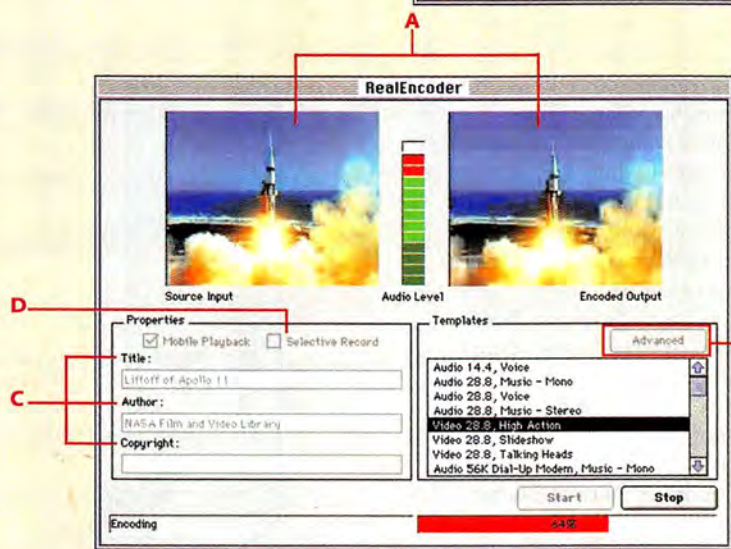
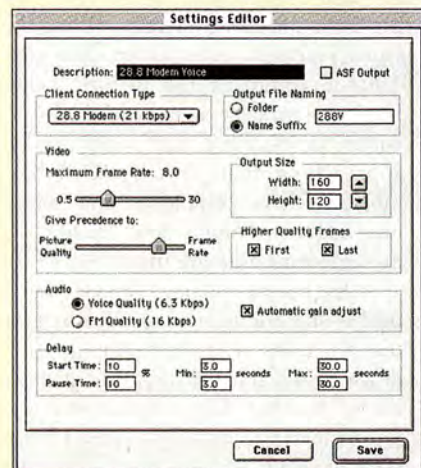
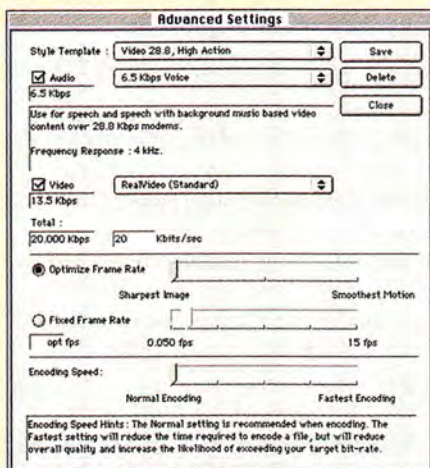

A Both encoders display before and after views of the movie while encoding.

B To customize the quality and data-rate settings, click here and enter specified settings in the resulting dialog boxes.

C The Title, Author, and Copyright information you enter here appears in the RealPlayer during playback.

D Checking Selective Record lets surfers save a RealVideo movie for later viewing.

videocassette, and Hi-8 equipment all deliver less noise than S-VHS and VHS.

Cut quickly. In editing, think twice about using transitions, even such mainstays as dissolves and wipes. Use jump cuts—switching suddenly from one scene to another—whenever possible. Avoid rapid-fire cutting too. It takes time for video to sharpen up after a change of scene, and the more cuts, the more fuzziness your viewers must endure.

Using Existing Video

The advice above yields relatively sharp, albeit somewhat bland, Web video. But what if you have existing video that violates every rule in the book? One option is to simply compress the video as-is and let the pixels fall where they may. You'll get chunky, jerky results, but Web users are often willing to forgive some flaws in exchange for a look at the cutting edge.

Speaking Encode

To prepare your video for Web viewing, you need encoder software that supports your streaming-video technology. For RealVideo, that is RealNetworks' free RealEncoder (you can download it from www.real.com/encoder/). For VivoActive, you need either Vivo's \$199 VivoActive Producer or the company's \$49 VideoNow. The latter supports only one frame size (a tiny 160 by 120 pixels), encodes for modem speeds only (no ISDN or faster), and lacks several quality-optimizing settings.

These encoders all work similarly. You specify a QuickTime movie to encode, and then you choose a preset combination of settings for movie frame size, frame rate, and sound quality (see "Inside Encoders"). You can fine-tune these settings or create new ones, but the presets are adequate for most efforts.

Encoding RealVideo in Adobe Premiere

RealNetworks' Adobe Premiere export plug-in gives you more control than RealEncoder over which frames are encoded. Most of the plug-in's settings are identical to their counterparts in RealEncoder. The difference is in the plug-in's Marker Options area, which has buttons that let you take advantage of Premiere's markers feature. Markers are electronic bookmarks within clips;

they let you quickly locate a particular section of a clip or align clips.

In RealVideo, markers also let you control which frames of the movie are encoded. Usually, some frames in a movie are more important than others. By marking these frames and choosing the right settings in the export plug-in, you ensure that the most-important frames will be encoded.



1 Create the Markers

To create a marker for a specific frame, navigate to that frame and then press shift=equal sign (=).

TIP You can make a slide show and save bandwidth. Here's how: Say you have a video clip containing landscape scenes—a meadow, a flower close-up, a lake—and it also contains a soundtrack with music and narration. Encode it normally—let the encoder plug-in choose which frames to discard in order to meet your chosen bandwidth—and you'll get a RealVideo movie containing multiple frames where nothing really changes, except maybe a few ripples in the lake. If you create one marker for each scene and encode the clip with the Slide Show Frames option selected, the resulting RealVideo clip will contain one frame per scene, with plenty of bandwidth left over for a great-sounding soundtrack.

RealEncoder includes an Adobe Premiere export plug-in that provides features for controlling exactly which video frames are encoded. If you edit in Premiere, this plug-in can yield better-quality video, particularly with video that was not shot with the Web in mind (see "Encoding RealVideo in Adobe Premiere").

Regardless of which encoding tool or streaming technology you use, it's a good idea to create multiple versions of a movie, each tailored for a specific bandwidth. The most common ones are 28.8-Kbps and 56-Kbps, but if you have the time, consider creating a 128-Kbps (ISDN) version too.

Serving Strategies

Once you've encoded your movies, you need to serve them to your visitors. You can serve RealVideo files in two ways.

continues

2 Specify Marker Options

To encode the movie and set marker options, choose RealEncoder from the File menu's Export submenu.

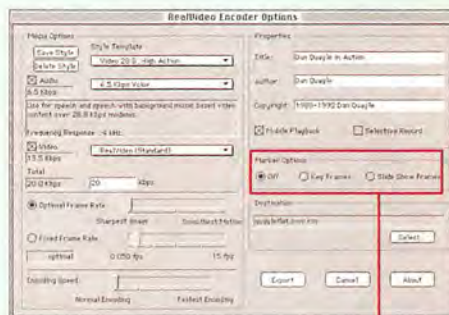

- A** The export plug-in ignores markers when encoding.
- B** The plug-in encodes every frame that has a marker (it may include other frames, depending on which encoding settings you select).
- C** The plug-in encodes only the frames that have markers.

HTML for Video

Once you've encoded your movie, you're ready to make it available to your site's visitors. Upload it to your Web server as you would an HTML page or graphic, and then create the appropriate HTML as described here.

Create the Metafile As with RealAudio, you can't simply refer to a RealVideo clip in a link—doing so would cause the RealPlayer software to download the entire clip before playing back. Instead, you must create a metafile, a one-line text file that references the RealVideo .RM file—for example, http://www.your_domain.com/liftoff.rm (if you're using RealNetworks' server software instead of HTTP streaming, use `pnm:` as the locator instead of `http:`).

Referencing the Clip You can use conventional hyperlinks to reference the metafile's clip, or you can embed it directly within the page. Hyperlinks are easier—just use the `<HREF>` tag to reference the metafile. But embedding enables you to create a custom interface for the clip, such as the one shown at the top right.

```

embed html
<HTML>
<HEAD>
<TITLE>
Embedded RealVideo Movie
</TITLE>
</HEAD>
<BODY BGCOLOR="#336699" LINK="#CCFFFF">
<br><br>
<TABLE BORDER="0" CELLSPACING="0" CELLPADDING="0" ALIGN="left">
<TR>
<TD ROWSPAN=3>
<TD>
<TD ROWSPAN=3>
</TR>
<TR>
<TD colspan="3">
</TR>
<TR>
<TD colspan="3" BGCOLOR="#336699" HEIGHT=204 WIDTH=178>
The liftoff of Apollo 11
</TD>
</TR>
</TABLE>
<!-- Begin embedded player/ActiveX code -->

```

An HTML table (highlighted) positions the bevel-edge graphics as a frame. Not shown here are lines of code you need for embedding the clip in your page. To see the entire HTML source for this page, go to www.macworld.com/more/.



Embedded clips can have custom frames.

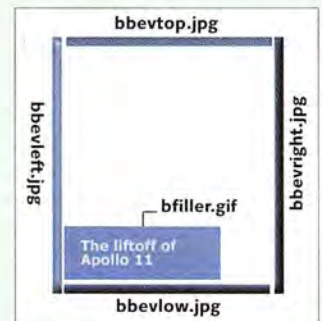

The clip's beveled edges are four separate JPEG graphics; the title is a graphic too.

The preferred way is to use RealNetworks' server software—it transfers data using the *User Datagram Protocol* (UDP), which helps ensure more-reliable playback and lets visitors drag a slider to jump around in a movie.

The second way is to use the same HTTP server software that's dishing out your Web pages. If you're running your own server now, you can use the same box to spew video streams. If a service provider or online service hosts your pages, you can simply upload video clips in the same basic way that you upload graphics and HTML files (although with RealVideo, you must also create a metafile—see "HTML for Video").

But HTTP streaming isn't as reliable as UDP streaming and doesn't use network bandwidth as efficiently. And from a viewer's standpoint, HTTP streaming doesn't permit the same degree of random-access flexibility. For example, viewers can jump forward to a spot located five minutes into a RealVideo movie, but they may have to wait until everything up

to that point has been downloaded before playback resumes. UDP streaming doesn't have this limitation.

The decision to use RealNetworks' server software or conventional server software used to be one of economics: RealNetworks' server software started at about \$1,000. That changed with the arrival of the free Basic Server. It serves RealAudio and RealVideo clips to as many as 60 visitors at once (depending on your Internet connection's speed—60 simultaneous streams consume roughly half of a T1 line's capacity; a dual-channel ISDN line handles about 12).

Like other RealNetworks' server software, Basic Server is available for Windows 95, NT, and various flavors of Unix. It isn't available for the Mac OS, but RealNetworks says it may develop servers for Apple's forthcoming Rhapsody OS. Many Internet service providers offer hosting services for RealNetworks' server software; check out RealNetworks' Web site (www.real.com) for details.

VivoActive relies on HTTP streaming exclusively. One side effect of this is that the VivoActive plug-in and player do not provide random-access features: playback controls are limited to play and pause buttons. But on the plus side, VivoActive image quality is excellent. And the VivoActive plug-in and player download the video clips in a way that uses network bandwidth more efficiently than does RealVideo HTTP streaming.

You Too Can Be a Broadcaster

Streaming video is another example of how the Web democratizes broadcasting. Sure, it's useful for CNN Interactive and for companies offering training videos on intranets, but it's also useful for video hobbyists, independent filmmakers, and proud parents. RealNetworks deserves much of the credit, giving away its top-notch encoder and enabling the delivery of RealVideo with standard HTTP servers. **m**

JIM HEID's latest book is *HTML & Web Publishing Secrets* (IDG Books Worldwide, 1997).

Prices may vary. Maximum engine rated speed is 9 FPM in economy mode. Actual print speeds vary depending on system configuration, substrate application, page complexity, page complexity, amount of page covered and print settings. EPSON, Stylus are registered trademarks of Seiko Epson Corp. Micro Piezo and PerfectPicture are trademarks of Epson America, Inc. © 1998 Epson America, Inc.



AT 360 DPI
YOU SEE
A JUGGLER.

AT 720 DPI YOU SEE
HE'S LOOKING AT
HIS REFLECTION.

YOU'VE GOT TO SEE IT IN

EPSON

COLOR.

AT 1440 DPI YOU SEE
THE REAL JUGGLER
IS ON THE BOTTOM.

Notice the ripple near the top left corner? See how the whole top image is darker? What reveals one image as reflected and another as real is all in the details – and our printers captured every one of them. Because they're designed with our exclusive PerfectPicture™ Imaging System. You get 1440 x 720 dpi for incredible detail. Micro Piezo™ Technology for a cleaner, consistent dot. And Photo Quality color with laser-sharp black text – for print quality that's already won 62 major awards, including PC Magazine's Editor's Choice. In standard format or wide format. With PC/Mac compatibility. Optional internal Ethernet. Up to 9 ppm blk/7 ppm color on the EPSON Stylus® Color 850. For more information, call 1-800-GO-EPSON (ask for Operator 3010) or visit us at www.epson.com. It could turn your world upside down.

**PRESENTING THE WORLD'S FIRST 1440 DPI
COLOR INK JET PRINTERS.**



\$799

\$399

EPSON Stylus® Color 850. High-performance business printer.

EPSON Stylus® Color 1520. The versatile wide-format printer.

Distorted Reality—the Magic of Displacement Mapping

Realistic Distortion Using Photoshop and After Effects

by David Biedny and Nathan Moody

When our friends at Pull Down Your Pants Productions (founded by three very talented ex-Industrial Light & Magic folks) asked us to contribute visual effects for their motion picture debut, *Spawn*, we started mentally preparing our arsenal of distortion effects. A specific technique immediately came to mind for many of the effects we needed to create: *displacement mapping*. If you watch movies or TV, you're familiar with displacement maps, whether you know it or not. They appear in a wide range of special effects, from the subtle and realistic (such as warping a texture or shadow to follow the contours of an object onto which it's composited) to the extreme and fantastic (making reality bubble and seethe before your eyes).

Many people—including seasoned imaging professionals—don't realize that displacement maps can create stunning

still-image effects too. In fact, it's easier to grasp the way displacement maps work if you start with still images in a program like Adobe Photoshop. You can then build on your knowledge to do even more complex effects in moving pictures with something like Adobe After Effects.

Displacement Basics

First, let's review the essential concept behind image displacement. Displacement mapping uses the brightness values of pixels in one image (the displacement map) to move pixels in another image (the target). Map pixels that are 100 percent white move the corresponding target pixels a user-specified amount in one direction (the positive offset), while map pixels that are 100 percent black move target pixels the same amount, but in the opposite direction (the negative offset).

Map pixels that are 50 percent gray produce no offset, while pixels in other shades of gray produce offsets that are

The Basics

The best way to get a grasp of how displacement mapping works is to see it in action. You'll find Photoshop's Displacement filter among the Distort filters (Filter > Distort > Displace).



The happy couple on the left is our target, the image to be displaced. The gradient on the right is the displacement map, whose brightness will be used to offset the pixels in the target.

smaller than the user-specified amount. Positive offset values usually represent movement left and up; negative values usually represent movement right and down. (The whole concept is a lot easier to understand with visual aids, so check out "The Basics").

The beauty of this technique is that it lets you warp images with a high degree of control. You can use gradients to shift pixels gradually so that an image appears to stretch, and you can use curves to make an image seem to sag in the middle. In effect, you can turn any image into a mold and drape a second image over it.

Map Your Way to Realistic Shadows

How can displacement mapping be used to address a real-world Photoshop problem? If you do image compositing and have never used displacement mapping to process synthetic shadows, you'll be pleasantly surprised by the results. Here's an example of how the Displace filter can be used to enhance the realism of an otherwise flat drop shadow.

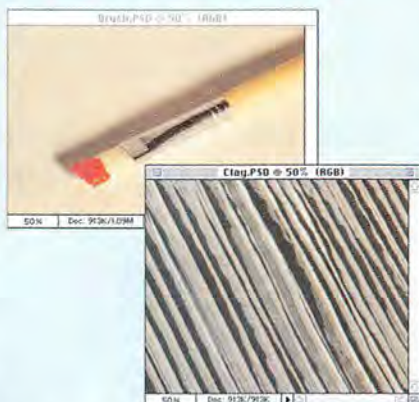

We can create a composite image of a brush against a background of clay from these two files.



We masked the brush, selected it, and placed it into the clay image, on a separate layer. A few simple modifications help make the lighting of the brush and the background match. Matching apparent lighting and brightness is crucial in compositing!

Darkening the clay background in the upper right-hand corner better simulates realistic lighting. Flipping the brush horizontally and repositioning it better matches the lighting of the background layer.

The Displace filter's dialog box governs all aspects of the distortion effect.

Moves pixels horizontally (positive = left, negative = right) and vertically (positive = up, negative = down)

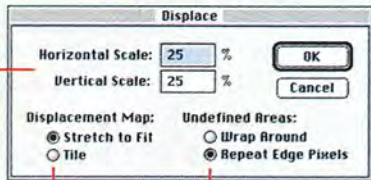

Scales map up or down to match target (top) or fills empty area by repeating map as a tiled pattern (bottom)

Wraps target's displaced edges around image (top) or repeats target's original edge pixels (bottom)

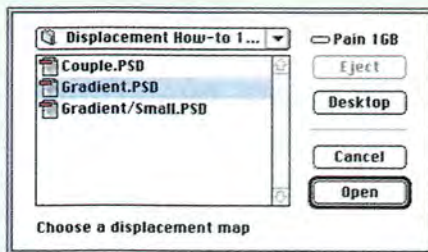

After determining the displacement settings, Photoshop asks you to designate the displacement map file you'd like to use.



Here's the result. Notice how the bright top region of the displacement map has shifted the target pixels up and to the left, while the dark lower region has shifted the target pixels down and to the right. The amount of offset falls off toward the middle of the displacement map, as the gradient approaches 50 percent gray.

Displacement Maps in Photoshop

Various applications offer displacement mapping; two common ones are Photoshop and After Effects. (Higher-end 3-D software packages offer related, but different, displacement functions.) Although the basic concepts are the same no matter where you use them, the specifics vary for different programs. Here are some things to keep in mind when using Photoshop's Displace filter.

• **Color mode is important in Photoshop displacement mapping.** The target image and the displacement map can be in any color mode except Bitmap, but one

mode—CMYK—works differently from the rest. If the target is a CMYK image, the displacement results are the opposite of what we described above. That is, white pixels in the map move CMYK target pixels up and to the right; black map pixels move them down and to the left.

• **Channels control displacement.** Photoshop's Displace filter takes into account the number of channels in the displacement map. In a single-channel document the brightness values displace target pixels both horizontally and vertically; in a multichannel document, however, the brightness values in the first channel dis-

place target pixels horizontally, while brightness values in the second channel displace target pixels vertically. Displacing with an RGB map, for example, results in the Red channel's creating the horizontal offset and the Green channel's creating the vertical offset. (Unless you explicitly plan for this, converting color images to gray scale may yield more predictable results.)

• **Photoshop calculates displacement as a percentage.** The offset values are expressed as percentages, based on a maximum offset of 128 pixels. For example, a black displacement map with an off-

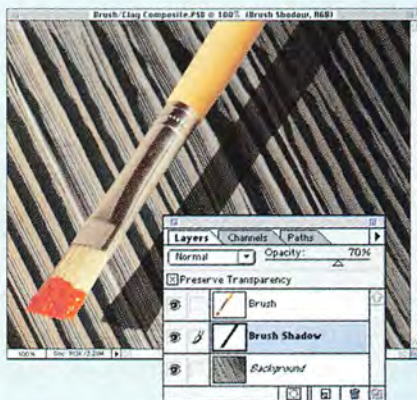

To create the shadow, we duplicated the brush layer, filled it with black, and moved it to the right. We repositioned the shadow layer underneath the original brush layer.



Before applying the displacement map, we rotated and repositioned the shadow to make the brush look as if it's at more of an angle to the background. We added a layer mask to decrease the shadow's opacity as it gets farther from the tip. But as you can see, the shadow still doesn't conform to the physical contours of the background, as it would in real life. That's where displacement mapping can help.

continues

After Effects: Displacement over Time

PHOTOSHOP ISN'T THE ONLY PLAYER in town when it comes to displacement mapping. In fact, After Effect's displacement effects can create even more visual mayhem by animating distortion effects over time. In contributing visual effects for the movie *Spawn*, one of our tasks was to generate a vapor that escapes a wounded creature's body. Our tool of choice—After Effects—doesn't exactly have a Monster Wound Vapor filter, but we found a way to create the effect we wanted using particle systems and some creative displacement mapping.

The first step of the solution seemed fairly obvious: start with a particle system, usually a good way to simulate vapors and gases in special effects. We chose the FE Particle effect from the Final Effects plug-in suite (from MetaCreations). The results, unfortunately, were not chaotic enough, with the particles traveling in a fairly linear fashion. How were we to get these particles to flow naturally, to introduce some realistic entropy?

We immediately thought of displacement mapping. Since the effect was animated, it didn't make sense to displace an animated particle stream with a still image—it would look as if the particles were flowing around a static, unseen object. But what would happen if we displaced one particle stream with a second one?

We placed a new particle system in its own composition and gave it larger particle shapes (Faded Spheres, in this case). Then it was time to try using this particle system as the displacement for the first system. After Effects needs rendered pixels to displace other layers; that means algorithmic effects such as particles must be prerendered (and imported as a QuickTime movie or PICT sequence) or placed in nested compositions for displacement mapping to work. Rather than render out the entire particle system beforehand, we simply placed it in a nested composition.

This technique wound up being the basis for many of our effects in *Spawn*. We displaced generic lightning arcs to create unique bubbling, weaving energy bolts. By displacing simple glows we were able to form rippling, moving auras. Static fields of bubbles were displaced to create ebbing clouds of vapor. But these possibilities are only the tip of the iceberg. What might happen if you have more than one displacement effect on a single layer? What if a particle system was displacing only someone's face as he or she spoke a line of dialogue? What if a displacement effect was used (in conjunction with traveling mattes and alpha channels) as the basis of a transition? There's really no limit to the creative potential of animated displacement mapping.



We were able to transform a simple particle stream into a gaseous animated effect, thanks to After Effects' Displacement Map effect and MetaCreations' Final Effects particle system plug-ins.

"Map Your Way to Realistic Shadows," continued

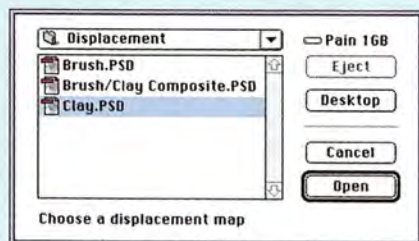

Using the original background file as a displacement map, we set the Displace filter for a 5 percent horizontal and vertical offset. The Brush Shadow is the target layer.

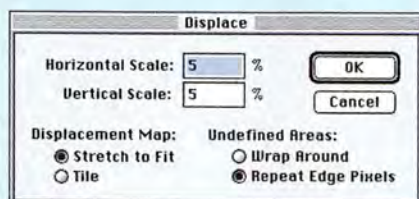

The resulting displacement, slightly blurred for realism, seems to make the shadow conform to the dimensional bumpiness of the background image.

TIP It's usually better to displace a shadow before adding blurring or other effects. Otherwise, a harsh edge in a displacement map might suddenly offset a blurred edge and detract from the effect's realism.

Step 1

In our first attempt at creating an unearthly gaseous vapor, we tried MetaCreations' FE Particle filter. The result is an animated, but primarily linear, effect. The particles radiate from the emission point (A) but never deviate from their initial trajectory as they fade out (B). We wanted something with chaotic motion and character.

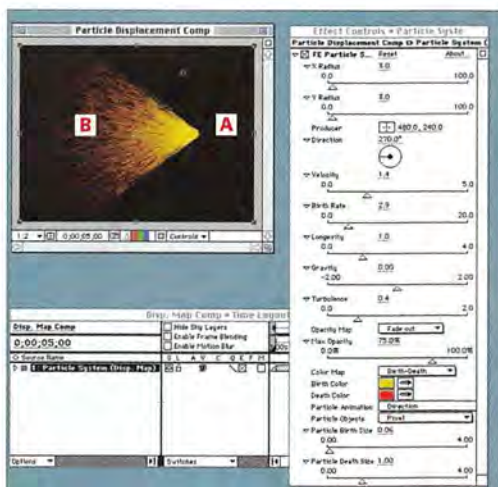

Step 2

We created a second particle system, with a wider spread (C), larger particles (D), and different particle objects (E). The background is 50 percent gray, to ensure no displacement of other elements.

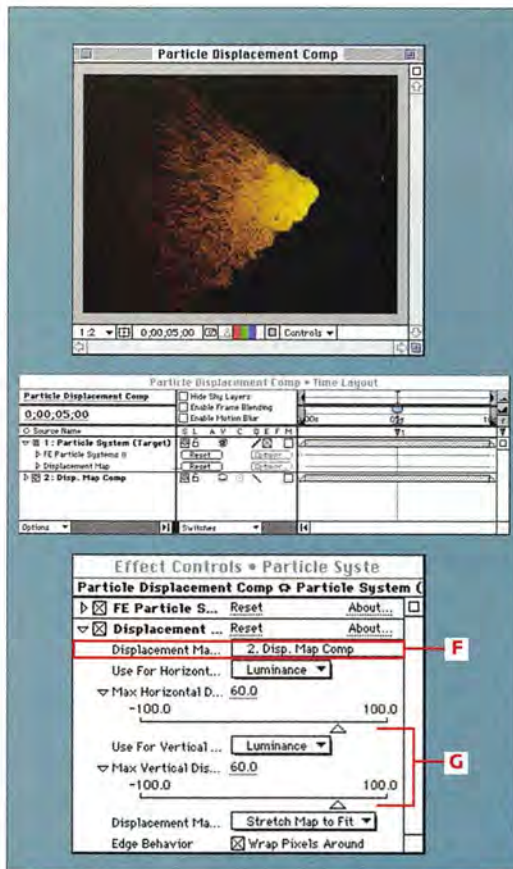
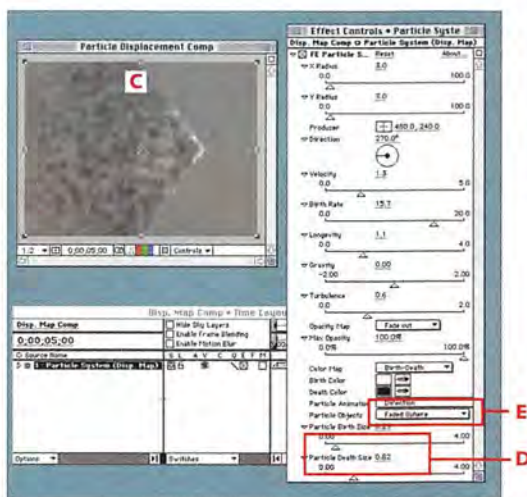

The Result

With the nested composition as a displacement map (F), the particle system target gets distorted in a very fluid way. The relatively high displacement settings (G) create a more obvious turbulence. (Note that a displacement map doesn't need to be, and often shouldn't be, visible when you create your effect, but it must be included in your current composition.)

set of 50 percent would move a target pixel 64 pixels down and to the right.

• **Mismatched map and target sizes can create problems.** Having displacement maps that are the same size as your target will yield the smoothest, most accurate results. If the two images are different sizes, Photoshop must deal with the discrepancy somehow. You can specify that Photoshop scale the map image to match the target image (this throws off the percentage of displacement that you specify), or you can have Photoshop use the map image as a tile, repeating the image to fill up the extra space (this makes it even harder to predict your results).

Displacement in After Effects

After Effects adds a few twists to displacement mapping: animation (using a movie file as the displacement map) and

interpolating effects over time (animating the behavior and positions of both the displacement map and the image being displaced). Here are some key issues to be aware of when you plan an After Effects displacement effect.

• **Pixel offsets work the same as in Photoshop.** In After Effects, white offsets pixels by the user-specified amount, black moves them the opposite direction, and 50 percent gray has no effect.

• **You specify offset in pixels.** This is a more accurate way to gauge potential distortions than Photoshop's percentage-based settings, and the maximum possible offset is 32,000 pixels.

• **After Effects has more precise controls than Photoshop.** After Effects can use the luminance of a layer's red, green, blue, or composite color channel as a displacement map. Horizontal and vertical

displacement maps can be specified independently; you're not tied to an image's first two channels as in Photoshop.

Whether it's in Photoshop or After Effects, displacement mapping is an incredibly versatile distortion effect that can range from subtle and simple to over-the-top and complex, depending on how it's used. Used properly and with some restraint, it's stunning on still images and mind-blowing when animated. The Hollywood special-effects community has been quietly using this amazing technique for years; the power is now in your hands as well. **m**

DAVID BIEDNY and NATHAN MOODY recently coauthored (with Bert Monroy) *Photoshop Channel Chops* (New Riders Publishing, 1998). They also created a variety of digital special effects for New Line Cinema's motion picture *Spiran*.



AFTER 17 YEARS, MATT IS STARTING A NEW LIFE.

WITH YOUR NAME AND SOCIAL SECURITY NUMBER.

Until now, when you gave out personal information on the web you had no idea where it could end up. The TRUSTe symbol gives you the power to find out.

TRUST·e

www.truste.org

TRUSTe is an independent non-profit initiative sponsored by: AT&T, CyberCash, Excite, IBM, InterNex, Lands' End, MatchLogic, Netcom, Netscape, Oracle, Tandem and Wired. ©1997 TRUSTe

Introducing a NEW Service to Macworld Readers...



www.macworld.com/getinfo

Macworld's **NEW** **ONLINE** Reader Service

Introducing Get Info. Now you can get information on all the products and services you see in *Macworld*. Only get it faster. Simpler. Better. Now. All you have to do is visit one Web site:

www.macworld.com/getinfo

Then select the products, product categories or advertisers for whom you want to receive information.

That's it. You can have the information delivered to you by e-mail, postal mail or even telephone. Or you can click on a link that will take you straight to the vendor's Web site in one easy step.

It's quick. Convenient. Fast. So next time you're interested in a product, don't get a stamp. Get Info.

Macworld

aGORA

SOUL OF THE ORACLE



Battle will commence June 98

Say you saw it in Macworld. To purchase products advertised in this issue call the phone numbers below or use the reader service number for our Product Information Card located after the product index.

Page No.	Advertiser	Reader Svc. No.	Phone	Page No.	Advertiser	Reader Svc. No.	Phone	Page No.	Advertiser	Reader Svc. No.	Phone
102	Adobe	—	800/521-1976	35	Infowave	32	800/865-5501	69	Mitsubishi Electronics America	261	800/843-2515
10	Agio Designs	—	800/688-2446	11	Intergraph Computer Systems	9	—	141	Macworld Expo	—	617/361-6000
49	American Power Conversion	72	888/289-APCC	58	Interland, Inc.	10	—	IBC	NEC Technologies	36	800/NEC-INFO
6	ANTHRO	—	800/325-3841	55,57	Iomega - Zip	—	—	59	Newbridge Communications, Inc.	—	—
IFC,1	Apple Computer	—	—	9	IXMICRO	53	888/467-8282	12,13	Newer Technology	55	—
29	ATI Technologies, Inc.	256	—	136	J&R Computerworld	282	800/221-8180	113	NewTek Incorporated	14	—
139	Bottom Line Distribution	221	—	BC	Kensington Microware Ltd.	1	800/535-4242	7	Orange Micro	33	714/779-2772
37	Caere Corporation	69	800/535-SCAN	41	Kingston Technology Corporation	201	800/435-0677	33	Pantone	202	—
130,131	ClubMac	96	800/CLUBMAC	132	L.A. Trade	—	800/433-3726	118	Power Media	43	—
137	Computer Discount Warehouse	2	800/861-4CDW	4,5	La Cie	52	—	123	ProDirect	135	800/524-9952
17	Deneba Software	57	800/733-6322	10	Legacy Electronics	35	888/466-3853	133	The LLB Company	220	800/848-8967
18	Diehl Graphsoft	46	410/290-5114	80	Linotype	17	—	134,135	The Mac Zone	70	800/436-0606
138	Digital Graphix	36	800/680-9062	43	MacSoft	23	—	117a	Trust e	—	—
96	Encad, Inc.	65	800/45-ENCAD	45	Mac Soft	28	—	27	Umax Computer	43	888/625-UMAX
113a,113b	Epson	—	—	95	Mac Soft	30	—	101	ViewSonic	11	800/888-8583
85	Extensis	14	800/796-9798	128,129	MacConnection	145	800/800-3333	8	VST Technologies, Inc.	74	508/263-9700
86	Fujitsu	202	800/626-4686	124,125	MacMall / Creative Computers	131	800/222-2808	53	Whistle Communications	84	888/4whistle
20,21	GCC Technologies	43	—	47	Macromedia	37	800/945-9179	61	Xerox Corporation	100	—
99	Hewlett Packard	11	800/851-1170	126,127	MacWarehouse	150	800/434-3035				
108	Hitachi NSA	74	800/441-4832	92	Matrox Graphics	—	—				
176	IDG Books	—	—	140	MegaHaus	229	—				
				14	MetaCreations Corp.	5	800/846-0111				
				25	Micromat	46	800/829-6227				
				51	Microtek Lab, Inc.	—	800/654-4160				

Macworld Product Index

A quick and easy product index from Macworld. Simply use this index to find the page or advertiser of the products which interest you. Then, use the reader service number for our FastFacts Product Information Card located on the following page.

Page No.	Advertiser	Reader Svc. No.	Page No.	Advertiser	Reader Svc. No.	Page No.	Advertiser	Reader Svc. No.	Page No.	Advertiser	Reader Svc. No.
SOFTWARE			HARDWARE						SYSTEMS		
CAD/CAM			BOARDS						IFC,1 Apple Computer —		
18	Diehl Graphsoft	46	29	ATI Technologies, Inc.	256	4,5	La Cie	52	138	Digital Graphix	36
ENTERTAINMENT			9	IXMICRO	53	92	Matrox Graphics	—	124,125	MacMall / Creative Computers	131
43	MacSoft	23	10	Legacy Electronics	35	123	ProDirect	135			
45	Mac Soft	28	12,13	Newer Technology	55	INPUT DEVICES			ACCESSORIES		
95	Mac Soft	30	7	Orange Micro	33	BC Kensington Microware Ltd.			FURNITURE		
118	Power Media	43	COMPUTER SYSTEMS						10 Agio Designs —		
GRAPHICS/DTP			27	Umax Computer	43	MISCELLANEOUS			MAIL ORDER		
102	Adobe	—	DIGITIZERS/SCANNERS						139 Bottom Line Distribution 221		
17	Deneba Software	57	51	Microtek Lab, Inc.	—	49 American Power Conversion			130,131 ClubMac 96		
85	Extensis	14	DISPLAY			53 Whistle Communications			137 Computer Discount Warehouse 2		
35	Infowave	32	108	Hitachi NSA	74	57 Whistle Communications			138 Digital Graphix 36		
47	Macromedia	37	4,5	La Cie	52	NETWORKING			136 J&R Computerworld 282		
14	MetaCreations Corp.	5	69	Mitsubishi Electronics America	261	11 Intergraph Computer Systems			132 L.A. Trade —		
33	Pantone	202	IBC NEC Technologies			53 Whistle Communications			128,129 MacConnection 145		
MISCELLANEOUS			101	ViewSonic	11	POWERBOOK			124,125 MacMall / Creative Computers 131		
118	Power Media	43	EXPANSIONS/UPGRADES			8 VST Technologies, Inc.			126,127 MacWarehouse 150		
MULTIMEDIA			132	L.A. Trade	—	PRINTERS			140 MegaHaus 229		
47	Macromedia	37	10	Legacy Electronics	35	96 Encad, Inc.			123 ProDirect 135		
113	NewTek Incorporated	14	HARD DISKS/STORAGE			20,21 GCC Technologies			133 The LLB Company 220		
OCR			139	Bottom Line Distribution	221	99 Hewlett Packard			134,135 The Mac Zone 70		
37	Caere Corporation	69	130,131	ClubMac	96	92 Matrox Graphics					
UTILITIES			86	Fujitsu	202	SECURITY					
35	Infowave	32	55,57	Imega - Zip	—	49 American Power Conversion			72 DIRECTORY 172		
25	Micromat	46									
6	ANTHRO	—									

Macworld puts you in touch with the information you need most with three easy options:

1 www.macworld.com/getinfo
Go Online

Direct your browser to the URL above, then select the products, product categories or advertisers for whom you want to receive FREE information. You can then choose to have the information delivered to you by e-mail, postal mail or even telephone.

2 dial 503.684.5370
Fax In Card

Simply fill in the questionnaire, circle the reader service numbers that correspond to the vendors you would like information from, then fax your form to us at 503.684.5370. FREE product information will be sent to you directly from vendors.

3 postage pre-paid
Mail In Card

After filling in the questionnaire, circle the reader service numbers that correspond to the vendors you would like information from, then just drop the postcard in the mail. Vendors will send FREE product information directly to you.



Check this box to subscribe to Macworld

YOU WILL BE BILLED \$24 FOR A ONE-YEAR (12 ISSUE) SUBSCRIPTION (US ONLY). SUBSCRIPTION WILL BE SENT TO NAME AS NOTED BELOW. PLEASE CHANGE IF MAILING ADDRESS IS DIFFERENT.

PLEASE ANSWER THESE QUESTIONS, CHECK ALL ANSWERS THAT APPLY

1a. For which of the following Mac-related products do you specify, recommend, approve, purchase or influence the purchase?

1b. Which of the following do you plan to purchase in the next 12 months? (Check all that apply.)

- | | Purchase Involvement | Plan to Buy |
|-------------------------------------|--------------------------|-----------------------|
| Desktops/PowerBooks | <input type="radio"/> 1 | <input type="radio"/> |
| Monitors | <input type="radio"/> 2 | <input type="radio"/> |
| Printers | <input type="radio"/> 3 | <input type="radio"/> |
| Storage Devices | <input type="radio"/> 4 | <input type="radio"/> |
| Networking/Data Communications | <input type="radio"/> 5 | <input type="radio"/> |
| Internet/Intranet products/services | <input type="radio"/> 6 | <input type="radio"/> |
| Software: business/productivity | <input type="radio"/> 7 | <input type="radio"/> |
| graphics/design | <input type="radio"/> 8 | <input type="radio"/> |
| interactive publishing/multimedia | <input type="radio"/> 9 | <input type="radio"/> |
| entertainment | <input type="radio"/> 10 | <input type="radio"/> |
| education | <input type="radio"/> 11 | <input type="radio"/> |
| other software | <input type="radio"/> 12 | <input type="radio"/> |
| Any other products | <input type="radio"/> 13 | <input type="radio"/> |

2. Are you employed, and involved in purchase decisions for 5 or more Macs? Yes (1) No (2)

3. What's Your Opinion?

What are your main frustrations in making Mac-related purchase decisions?

- 1. Lack of expertise in assessing products
- 2. Difficulty in installing or using products
- 3. Too many choices
- 4. Not enough choices
- 5. Unclear needs
- 6. Concern that cheaper, better products are about to come out
- 7. Other (please specify) _____

PRODUCT CATEGORY INFORMATION

For information on all of the products mentioned in an article or an entire category of advertised products, circle the appropriate number below.

- 951 Mail Order Companies
- 952 Printers
- 953 Scanner & Digital Cameras
- 954 Online/Internet
- 955 Storage Devices
- 956 Monitors & Graphics Boards
- 957 Utilities
- 958 Clip Art & Fonts
- 959 Memory
- 960 Draw/Paint/DTP Software
- 961 Image-Editing Software
- 962 Other Graphics Software

READER SERVICE NUMBERS FOR ADVERTISED PRODUCTS CAN BE FOUND IN THE PRODUCT'S AD AND IN BOTH THE ADVERTISER INDEX AND PRODUCT INDEX.

1	2	3	4	5	146	147	148	149	150	291	292	293	294	295	461	462	463	464	465	531	532	533	534	535
6	7	8	9	10	151	152	153	154	155	296	297	298	299	300	466	467	468	469	470	536	537	538	539	540
11	12	13	14	15	156	157	158	159	160	401	402	403	404	405	471	472	473	474	475	541	542	543	544	545
16	17	18	19	20	161	162	163	164	165	406	407	408	409	410	476	477	478	479	480	546	547	548	549	550
21	22	23	24	25	166	167	168	169	170	411	412	413	414	415	481	482	483	484	485	551	552	553	554	555
26	27	28	29	30	171	172	173	174	175	416	417	418	419	420	486	487	488	489	490	556	557	558	559	560
31	32	33	34	35	176	177	178	179	180	421	422	423	424	425	491	492	493	494	495	561	562	563	564	565
36	37	38	39	40	181	182	183	184	185	426	427	428	429	430	496	497	498	499	500	566	567	568	569	570
41	42	43	44	45	186	187	188	189	190	431	432	433	434	435	501	502	503	504	505	571	572	573	574	575
46	47	48	49	50	191	192	193	194	195	436	437	438	439	440	506	507	508	509	510	576	577	578	579	580
51	52	53	54	55	196	197	198	199	200	441	442	443	444	445	511	512	513	514	515	581	582	583	584	585
56	57	58	59	60	201	202	203	204	205	446	447	448	449	450	516	517	518	519	520	586	587	588	589	590
61	62	63	64	65	206	207	208	209	210	451	452	453	454	455	521	522	523	524	525	591	592	593	594	595
66	67	68	69	70	211	212	213	214	215	456	457	458	459	460	526	527	528	529	530	596	597	598	599	600
71	72	73	74	75	216	217	218	219	220	PLEASE PRINT OR TYPE ALL INFORMATION.														
76	77	78	79	80	221	222	223	224	225	Expires July 25, 1998. 51 April 1998														
81	82	83	84	85	226	227	228	229	230	MR GARY VOGT														
86	87	88	89	90	231	232	233	234	235	5065 WOLVERTON DR														
91	92	93	94	95	236	237	238	239	240	FLORISSANT MO 63033-4438														
96	97	98	99	100	241	242	243	244	245	E-mail _____														
101	102	103	104	105	246	247	248	249	250	Title _____														
106	107	108	109	110	251	252	253	254	255	Company _____														
111	112	113	114	115	256	257	258	259	260	Phone _____ Fax _____														
116	117	118	119	120	261	262	263	264	265															
121	122	123	124	125	266	267	268	269	270															
126	127	128	129	130	271	272	273	274	275															
131	132	133	134	135	276	277	278	279	280															
136	137	138	139	140	281	282	283	284	285															
141	142	143	144	145	286	287	288	289	290															

3 Simple Ways to Get **FREE** Product Information



FREE

Macworld puts you in touch with the information you need most with two easy options — fax back or mail in the reader service card.

Fax back. Mail in. Just don't miss out.

Fold here and close with tape. Do not staple.



50% TOTAL RECOVERED FIBER
10% POST-CONSUMER FIBER



NO POSTAGE
NECESSARY
IF MAILED
IN THE
UNITED STATES

BUSINESS REPLY MAIL
FIRST-CLASS MAIL PERMIT NO. 677 PORTLAND OR
POSTAGE WILL BE PAID BY ADDRESSEE



READER SERVICE DEPARTMENT
12950 SW PACIFIC HWY STE 7
TIGARD OR 97223-9747



of the (5 Time Award Winning) Speed-Tuned Hard Drives "an outstanding value in terms of price and performance... comes with easy to use formatting utility." PDS19101 Seagate Cheetah 9 Gig Wide. -MacWorld 3/98

ProDirect

800-555-1256



Service * Performance * Price * Always

Hard Drive from ProDirect...

Now with New Personal Choice Speed Tuning!

Only from ProDirect!

Speed-Tuned to YOU for the exact way you work:

CHOOSE YOUR SPEED TUNING

- AV Recording
- Desktop Publishing
- Multi-Purpose Use

PLUS MacWorld & MacUser Award-Winning Performance **PLUS** Tech Support from the pros that do more than pack boxes.

The Speed-Tuned Difference working closely with drive manufacturers to identify and optimize key internal mode settings for the Mac, our hard drives are calibrated to operate at peak efficiency. We call it "Speed-Tuning" and it works. The proof is in the awards our drives keep winning.

IBM ULTRASTAR Ultra Deal!

9.1 GB Narrow or Wide \$785
8ms Seek 512K Buffer 7200 RPM 5 Year Warranty

ULTRASTAR ES Reliability, Speed & Value

INTERNAL	EXTERNAL
2.1 GB (DCAS32160S) \$205	\$265
4.3 GB (DCAS34330S) \$335	\$385
9.1 GB (DCAS34330W) \$355	\$445

ULTRASTAR XP High Speed DTP & AV

INTERNAL	EXTERNAL
9.1 GB (DCHS39100S) \$785	\$845
18 GB (DCHS39100W) \$785	\$865

All IBM drives have 8ms Seek 512K Buffer 7200 RPM 5 Year Warr.

18 GB ULTRA SCSI WIDE \$1895 \$1975
3.5" Drive, 6.5ms Seek, 1MB Buffer, 7200 RPM, 5 Year Warranty

Ultra SCSI Acceleration Cards

ATTO EXPRESS PCI Ultra SCSI Single Channel..... \$345

ATTO DUAL CHANNEL EXPRESS PCI Ultra SCSI 3 40 MB/Sec. \$589

Seagate CHEETAH Fastest Drive Running

THE CHEETAH FAMILY BOASTS A 10,000 RPM SPINDLE SPEED WHICH GREATLY ENHANCES ITS OVERALL PERFORMANCE.

4.5GB Wide (ST34501W) \$695
9.1GB Wide (PDS19101W) \$1075
7.9ms Seek 512K Buffer 10,000 RPM 5YR. Warr.

BARRACUDA Legendary Performance

4.5GB Wide (ST34572W) \$575
9.1GB Wide (PD19171W) \$785
8ms Seek 512K Buffer 7200 RPM 5 Year Warranty

CHEETAH Fastest Drive Running!

INTERNAL	EXTERNAL
4.5 GB (ST34501N) \$575	\$635
9.1 GB (ST34501W) \$675	\$755
9.1 GB (ST19101N) \$985	\$1045
9.1 GB (ST19101W) \$1075	\$1155

7.9ms Seek 512K Buffer 10,000 RPM 5YR. Warr.

BARRACUDA Legendary Performance

INTERNAL	EXTERNAL
2.2 GB (ST32272N) \$385	\$445
4.5 GB (ST34572W) \$575	\$635
9.1 GB (PD19171W) \$775	\$835
9.1 GB (PD19171W) \$785	\$865

8ms Seek 512K Buffer 7200 RPM

ELITE Awesome Capacity!

INTERNAL	EXTERNAL
23 GB (ST423451N) \$1795	\$1895
23 GB (ST423451W) \$1845	\$1945

11ms Seek 2048K Buffer 5400 RPM

Quantum WOW! CAPACITY FOR THE EXTRAORDINARY

AV Speed Atlas II 2GIG \$255
7200 RPM 8ms Seek 512k Buffer (Q32275) 5 Year Warr. INTERNAL ONLY

VIKING \$365
4.5 GB (Q34550VK) 8.5ms Seek 512K Buffer 7200 RPM 5 Year Warranty

ATLAS II \$725
9.1 GB (Q39100) 8ms Seek 1024K Buffer 7200 RPM 5 Year Warranty

STRATUS New Heights of Value & Performance

INTERNAL	EXTERNAL	INTERNAL	EXTERNAL
2.1 GB \$225	\$275	3.2 GB \$255	\$315
4.3 GB \$295	\$355	6.4 GB \$395	\$455

9.5ms Seek 128K Buffer 5400 RPM 5 Year Warranty

ATLAS II Award Winning Reliability

INTERNAL	EXTERNAL
2.2 GB (Q32275N) \$295	\$355
4.5 GB (Q32275W) \$325	\$405
4.5 GB (Q34550) \$485	\$545
4.5 GB (Q34550W) \$515	\$595

8ms Seek 512K Buffer 7200 RPM 5 Year Warranty

VIKING Ultra Value and Performance

INTERNAL	EXTERNAL
2.2 GB (Q32275VK) \$275	\$335
4.5 GB (Q32275VKW) \$295	\$380
4.5 GB (Q34550VK) \$485	\$545
4.5 GB (Q34550VKW) \$515	\$595

8ms Seek 512K Buffer 7200 RPM 5 Year Warranty

ADAPTEC SPECIAL

PowerDomain 2940 UWM Single Channel PCI... \$195

PowerDomain 3940 UWM Dual Channel PCI... \$539

*with wide drive purchase

ADAPTEC FireWire SPECIAL

FireWire AHA 8945 Dual 1394 FireWire Ports and Wide Ultra SCSI Port... \$695

Get a PowerRAID for Maximum Data Transfer Rates

MacUser 8/97 BEST BUY

"The fastest array in this test, the ProDirect PowerRAID"

RAID Level 5 Available. Great for Servers!

All ProDirect PowerRaids are ready to use, Plug and Play and Include: Pre Configured Adaptec 2940 Ultra Wide Accelerator (Also available with High performance Multi Channel Accelerator), Raid-Tuned Hard Drives, ProDirect Raid Center Enclosures and "Premus Raid Software. And, all PowerRaid Components are covered by a 5 year 48 hour replacement warranty. At ProDirect we know that time means money...YOUR Money!

At ProDirect, we work closely with drive manufacturers to identify and optimize key internal mode settings. This enables our PowerRaids™ to operate at peak efficiency. We call it Raid-Tuning™ and it works. The proof is in the award, AGAIN!

Seagate PowerRAID SC18

18GB CHEETAH SPEED DEMON!

This Raid features drives rotating at 10,000 RPM which greatly enhances the overall transfer rate of this 18 GB Raid.

FIXED \$2995 REMOVABLE \$3195

Seagate PowerRAID SC36

36GB CHEETAH AWESOME SPEED!

This Raid features drives rotating at 10,000 RPM which greatly enhances the overall transfer rate of this 36 GB Raid.

FIXED \$5595 REMOVABLE \$5995

Seagate PowerRAID SB36

36GB BARRACUDA MASSIVE SPEED

This Raid features the proven Barracuda technology recommended for use with most video editing systems

FIXED \$5185 REMOVABLE \$5685

Seagate ProDIRECT PowerRAID Avid

GB	DRIVES	ACCEL CHANNEL	FIXED	HOT-SWAP
8	Barracuda ST3471W	Single	1825	1995
18	Barracuda ST19171W	Single	2695	2895
36	Barracuda ST19171W	Single	5185	5685
54	Barracuda ST19171W	Single	7795	8295
72	Barracuda ST19171W	Single	9695	10495

HIGH SPEED TAPE BACK-UP

IN STOCK TODAY

Speedy Tape Drives Perfect for AV Work or Server ON THE FLY INSTANT BACKUP!

CAPACITY	MODEL	TRANSFER RATE	SALE
3 GB	HP 1599	90 MB/Min.	1145
3 GB	CTD8000	60 MB/Min.	795
3 GB	Sony 7000	90 MB/Min.	975
24 GB	HP1554 DDS3	120 MB/Min.	1445
24 GB	Sony 9000 DD3	120 MB/Min.	1245
18 GB	HP1553 DDS2	60 MB/Min.	2485
50 GB	Sony AIT50K 3000 9mm	120 MB/Min.	3095
144 GB	HP1559 DDS3	120 MB/Min.	3995
150 GB	DLT™ 2500XT	150 MB/Min.	4895
210 GB	DLT™ 2700XT	150 MB/Min.	6535
200 GB	DLT™ 4500	180 MB/Min.	6525
280 GB	DLT™ 4700	180 MB/Min.	7995

RETROSPECT 4.0 SOFTWARE INCLUDED

INCREDIBLE DLT! 40GB DLT™ 4000 180 MB/Min. \$2989

SPECTACULAR SPEED! 50GB™ SONY AIT Up to 360 MB/Min. \$3095

BLISTERING SPEED 70GB DLT™ 7000 600 MB/Min. \$6985

AWESOME SPEED 30GB DLT™ 2000XT 150 MB/Min. \$2575

REMOVABLE STORAGE DRIVES

I OMEGA ZIP

100 MB Removable with One Cartridge

External: \$148
Internal PowerMac: \$158

ZIP Cartridges \$15.95 ea. \$12. ea. in 10-pack after rebate.

I OMEGA JAZZ

1GB Removable with One Cartridge

External: \$299
Internal PowerMac: \$298

JAZZ Cartridges \$88 ea.

SyQuest SYJET

1.5 GB \$289

SyJet Cartridges \$98 ea.

CD Recorders & Players

EXTERNAL \$535

Yamaha CDR 400
4 Speed Recorder/6 Spd Player Huge 2 MB Buffer \$585

CRW 4260 CD Re-Writable Recorder \$465

Panasonic CDR 7502 4X8X
4 Speed Recorder/6 Spd Player Huge 2 MB Buffer \$795

CD-HD Mastering System Featuring Panasonic CDR 7502 & IBM UltraStar 2 GB AV Hard Drive \$895

CD-RD Mastering System Featuring Panasonic CDR 7502 & Iomega 1GB Jazz Drive \$165

Pioneer 2x CDRom 90ms 3600K/Sec. \$135

Phillips 8x CD ROM \$135

MEMORY HIGHEST QUALITY LIFE TIME WARRANTY

DIMMS 168PIN 60ns	SIMMS 60ns	
SIZE	SVOLT	72PIN
16 MB	\$42	\$46
32 MB	\$77	\$83
64 MB	\$139	n/a

new G3 SDRAM DIMMS

APPLE CERTIFIED G3 MEMORY FOR NEW G3 POWERMACS	16 MB \$54
	32 MB \$89
	64 MB \$295
	128 MB \$585

As Much As \$300 IN REBATES

We Will Beat Any Computer Price!!!

We'll beat any price from any
Call us before you order from

Power Macintosh® G3!



Power Macintosh G3!

233MHz PowerPC™ G3
32MB RAM/4GB Hard Drive
24X CD-ROM

\$1,999!

#27104 (desktop) Model shown is #27106

Also Available from MacMail

#27660 Power Macintosh G3/233MHz G3/32MB RAM/4GB Hard Drive/24X CD-ROM/56K modem Mini Tower **New!** \$2,149

#27105 Power Macintosh G3/266MHz G3/32MB RAM/4GB Hard Drive/24X CD-ROM/Zip Drive/Desktop model \$2,399

Up to \$1000 Price Drop!

PowerBook 1400 Series Available from MacMail

New!

#27108 PowerBook 1400cs/166MHz 603e/16MB RAM/ 1.3GB Hard Drive/12X CD/11.3" Dual Scan display was \$2,299 Now \$1,749

#27115 PowerBook 1400c/166MHz 603e/16MB RAM 2GB Hard Drive/8X CD/11.3" Active Matrix display was \$2,999 Now \$1,999

Up to **166MHz**

PowerBook® 3400!



Up to **240MHz**

#27113 PowerBook 3400c/200MHz/16MB 2GB HD/12X CD/33.6 Modem 12.1" Active Matrix Display (shown) \$3,799

#27111 PowerBook 3400c/240MHz/16MB 3GB HD/12X CD/33.6 Modem 12.1" Active Matrix Display \$4,499



Macintosh PowerBook G3!

250MHz PowerPC™ G3 /32MB RAM/5GB Hard Drive/20X CD-ROM/ 33.6 Modem/12.1" Active Matrix Display

\$5,699! #27107

Mini Tower Macintosh®

250MHz PowerPC™ 603e/ 32MB RAM
2GB Hard Drive/4X CD-ROM/33.6 Modem
Built-in 12.1" Active Matrix Color Display

\$3,999! #27109



Up to **250MHz**



Memory

Starting as low as **\$2.50** per MB



#65416 Prices subject to change. Please call for most current pricing.

MacMail EXCLUSIVE!



Mac OS 8 & Speed Doubler 8 Plus—FREE RAM Doubler 2!

All Three Titles Only **\$99.99**

#11291

Price reflects \$30 mail-in upgrade rebate for owners of Mac OS 7.6. Price before rebate is \$129. *Must ask for free RamDoubler 2 when ordering. #11441

Take Advantage of this Special Offer: Mac OS 8 and a Teleport 56K modem Both Only \$178! Ask for #15027



Power Macintosh 5500!

225MHz PowerPC 603e/32MB RAM/2GB Hard Drive/24X CD-ROM/ Built-in 15" MultipleScan Display

\$1,899!

#27110



Up to **225MHz**

Power Macintosh 6500!

#27099 Power Macintosh 6500/250MHz 603e/32MB RAM/4GB HD/24X CD-ROM 56K modem Was \$1,999 Now \$1,499

#27100 Power Macintosh 6500/275MHz 603e/32MB/6GB HD/24X CD/56K modem Zip Drive Was \$2,499 Now \$1,799

#27101 Power Macintosh 6500/275MHz 603e/48MB RAM/6GB HD/24X CD/56K Modem/Zip Drive MS Office 4.2.1 Was \$2,799 Now \$2,099

#27103 Power Macintosh 6500/300MHz 603e 64MB RAM/6 GB HD/24X CD/ Zip Drive Was \$2,999 Now \$2,299

Monitor sold separately on all models.



Up to **\$700 Price Drop**

Up to **300MHz**

NEW Iomega® ZipPlus® Drive!

- > Includes 100MB disk
- > 5 CD titles included
- > SCSI/Parallel

\$199.99

#14647



Iomega® External 1GB Jaz® SCSI Drive

- > 6.7MB/sec transfer rate
- > Includes FREE Cartridge

\$299.99

#74475



GS771 17" Display Short Depth Design

- > 16.0" viewable
- > 1280 x 1024 max. resolution
- > .27mm dot pitch
- > 14" footprint

\$499.99

#25520



ViewSonic®

FREE Sony Speakers w/any monitor purchase from MacMail \$3.99 shipping and handling applies.

CD-R Media

\$99 per disc
after 20 mail-in rebate for 10-pk.
Price before rebate is \$29*
Ask for #99087



210MHz MAXpower G3 for Power Mac 6100

> 512K backside cache
\$499.99 #27217

#27219 210MHz MAXpower G3 /512K backside cache/Power Mac 7100/8100 \$599



RealPC & Stuffit Deluxe 4.5

Both for only **\$99.99**
#25995



We ship FedEx Federal Express

\$1.8 Billion in Available Inventory!

Over 45,000 Products!

Custom Configuration!

Fastest Overnight Delivery!

with your CPU purchase! of \$1000 or more.

authorized catalog reseller on any CPU we offer, anyone else. We want your business! Cannot be combined with Rebate offer.

MacMall Exclusive Instant Rebates!

Save up to \$300!

with MacMall Exclusive Instant Rebates on Apple and Umax Systems!

No Mail-in Hassles! No Quantity Limits!

And If That's Not Enough—Call Us! We Want Your Business!

Call your account representative for details.



The Ultimate Graphics System!



Up to **300MHz**

Power Macintosh 8600 & 9600

#27117	Power Macintosh 8600/300MHz/604e/32MB RAM/4GB HD 24X CD-ROM/Zip Drive	\$3,099
#27116	Power Macintosh 9600/300MHz/604e/64MB RAM/4GB HD 24X CD-ROM/Zip Drive	\$3,799

Monitor sold separately on all models.

UMAX
Computer Corporation

SuperMac C500/200MHz

PowerPC™ 603e
16MB RAM/2.1GB HD
12X CD-ROM
10Base-T ethernet

\$1095!

only #24833

Also Available from MacMall

#27118	UMAX SuperMac C600 vPC/240MHz 603e/32MB RAM 3.0GB Hard Drive/24X CD ROM Includes Insignia's Virtual PC	\$1,495
#27119	UMAX SuperMac J700 233MHz 604e/24MB RAM 2 GB HD/24X CD ROM/33.6Kbps modem/Mac OS 8	\$1,995

All monitors on UMAX systems are sold separately

Great Deals from MacMall!

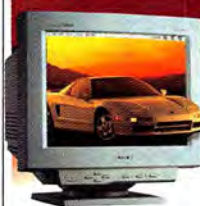

SONY 100sx Color Display

- ▶ 15" Color display
- ▶ 1280 X 1024 max. res.
- ▶ .25mm dot pitch

\$249⁹⁹!

#23973 (factory refurbished)

FREE Sony Speakers w/any monitor purchase from MacMall \$3.99 shipping and handling applies.



PalmPilot Professional Edition w/1MB RAM

- ▶ 5.7 oz and 4.7" long
- ▶ Includes: Date Book, Address Book, To Do List, Memo Pad, Security, Games and Hot Sync

for only **\$344⁹⁹**



FileMaker Pro 4.0

- ▶ Powerful data management
- ▶ Built-in CGI tools

\$89⁹⁹!

#14843 (upgrade)



Quicken Deluxe 98 & MacInTax Deluxe

Together For Only **\$59⁹⁹+**



#24627
*After 20 Quicken Deluxe /MacInTax users mail-in rebate for previous Quicken users and 15 MacInTax Deluxe mail-in rebate, plus additional \$5 rebate for bundle purchase.

Microsoft Office 98

Mac upgrade only
\$268⁹⁹
#26155

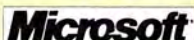

Stylus Color Pro Printer

- ▶ Up to 720 x 720dpi
- ▶ Optional PostScript
- ▶ Factory refurbished

\$189⁹⁹

#96717



Exclusive Offer!

2 Year Warranty

56K Data/Fax Modem

- ▶ PnP installation
- ▶ Caller ID
- ▶ FREE Data/Fax software

\$99⁹⁹
#95195

Incredible Price!



Astra 610s Scanner

▶ 30 Bit
▶ 8.5" x 11.7"
\$149⁹⁹
#25144
Rebate thru 2/28/98

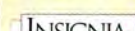

SoftWindows 95 5.0

Upgrade from 1.0 or 4.0 for only **\$99⁹⁹**
#25574



NEW Macromedia Dreamweaver

The Visual WebSite Design Tool!

▶ Roundtrip control between Visual and Source HTML
▶ Absolute positioning of layers
\$289⁹⁹ #25290



www.macmall.com

uBid-Check out our online auction! Bids Starting as low as \$7



Order Any Time! **1-800-217-9492**

Open 24 Hours.

Order Today by 11 pm EST—Get It Tomorrow by 10:30 am. Check out our Web site www.macmall.com

Use Source Code: #ZMWD841

MacMall

The Mall With It All...For Less!

We do our best to be accurate but occasionally mistakes occur. We are not responsible for any typographical, photographic or technical errors. Products and packaging may differ from stock available at time of shipment; we reserve the right to substitute equivalent items.

NEW! Apple Power Mac



Apple PowerBooks AS LOW AS

\$1749!

Price for PowerBook 1400CS/166MHz—Item# CPU0990, see below.
Shown is PowerBook 3400C/240MHz.

PowerBook 1400CS/166MHz/16MB RAM 1.3GB HD/
12X CD-ROM/11.3"/Dual-Scan display. While supplies last.
CPU0990 was ~~\$2299~~ **\$1749**

PowerBook 1400C/166MHz/16MB RAM
2.0GB HD/8X CD-ROM/11.3"/
Active-Matrix display.
CPU0745 was ~~\$2999~~ **\$1999**

PowerBook 2400C/180MHz
16MB RAM/1.3GB HD/
10.4" Active-Matrix display.
CPU0713 was ~~\$2499~~ **\$1999**

PowerBook 3400C/240MHz/16MB RAM
3.0GB HD/33.6K modem/
10Base-T Ethernet/12XCD
CPU0610 **\$4499**

UP TO **240MHz!**

MacWAREHOUSE

Ordering Information

- Our sales staff is ready to take your order 24 hours a day, 7 days a week.
- We accept the following major credit cards: Visa, MasterCard, Discover Card/NOVUS, AmEx. Your credit card will not be charged until each item is shipped (no surcharge).
- CT, IL, NJ, OH, and WA residents add applicable sales tax.
- Overnight delivery just \$4.95 per order up to 3 pounds. For all orders over 3 pounds, shipping is \$4.95 plus \$1.25 per pound or fraction thereof. (Example: a 4 pound order is \$6.20). Please add an additional handling charge of \$3.00 for all orders under \$50.00.
- Place your order for "in-stock" items up to 12:00 midnight (E) (weekdays), and we

will ship same day for overnight delivery (barring system failure, etc.).

6. Many of our products come with a 30-Day Money Back Guarantee. All items we sell come with the MacWAREHOUSE 30-Day Guarantee Against Defects.

© Copyright 1998 Micro Warehouse, Inc. MacWAREHOUSE® is a division of MicroWarehouse, Inc. MacWAREHOUSE® and MicroWAREHOUSE® are registered trademarks and Data Comm WAREHOUSE and MacSystems WAREHOUSE are trademarks of Micro Warehouse, Inc. Apple, the Apple logo, Mac and Macintosh are registered trademarks of AppleComputer, Inc. Item availability and price subject to change without notice. We regret that we cannot be responsible for typographical errors. All prices shown in U.S. dollars.

30 Day Money Back Guarantee

30-DAY Guarantee Against Defects



20th Anniversary Mac

Limited Edition Features:

- Dynamic Bose Acoustimass sound system
- Built-in Apple TV/FM Radio System
- 12.1" TFT active matrix color display

This ultra-slim design is as innovative as the first Macintosh 20 years ago!



New!

250MHz PowerPC 603e processor/32MB RAM/
2.0GB HD/CD, Ask for item# CPU1011 **\$3999**



PRICES SLASHED!

Power Mac 6500/275MHz shown. Monitor sold separately.

Apple Power Mac 6500

AS LOW AS **\$1299!** *
WHILE SUPPLIES LAST!

Power Mac 6500/225MHz: 32MB RAM/3GB HD/12X CD/33.6K Modem. CPU0625 was ~~\$1499~~ While Supplies last!... **\$1299***

Power Mac 6500/250MHz: 32MB RAM/4GB HD/24X CD/56.6K Modem. CPU0862 was ~~\$1499~~ **\$1499**

Power Mac 6500/275MHz: 32MB RAM/6GB HD/24X CD/56.6K Modem/Zip Drive. CPU0864 was ~~\$2499~~ **\$1799**

Power Mac 6500/275MHz: 48MB RAM/6GB HD/24X CD/56.6K Modem/Zip Drive. CPU0863 was ~~\$2799~~ **\$2099**

Power Mac 6500/300MHz: 64MB RAM/6GB HD/24X CD/56.6K Modem/Zip Drive. CPU0865 was ~~\$2999~~ **\$2299**

Apple Power Mac 8600/9600

- 250-350MHz PowerPC 604e processor
- 32MB-64MB RAM (exp. to 512-768MB)
- 4.0GB hard drive
- 24X CD-ROM drive
- 2MB-8MB VRAM
- Omega 100MB Zip drive



UP TO **350MHz!**

Monitor sold separately.

Power Mac 8500/250MHz shown.

Power Mac 8600/250MHz 32MB/4GB/24X CD/Zip Drive. CPU0850 **\$2599**

Power Mac 8600/300MHz 32MB/4GB/24X CD/Zip Drive. CPU0784 While supplies last! **\$3099**

Power Mac 9600/300MHz 64MB/4GB/24X CD/Zip Drive. CPU0785 **NOW ONLY! \$3499**

Power Mac 9600/350MHz 64MB/4GB/24X CD/Zip Drive. CPU0786 **NOW ONLY! \$3999**

WOW! 1440 dpi! New Low Price!

Epson Stylus Color 600 Printer

ONLY **\$249!** Was \$369!

Stylus Color 800 Printer (shown) Item # PR12127 ONLY \$349

- 1440 x 720 dpi
- Up to 7ppm color

Item# PR12126

Canon BJC-4550 Color Printer

ONLY **\$299.95!**

- Prints on paper up to 11" x 17"
- 720 x 360dpi
- 5ppm black/1ppm color
- 1 Year warranty

Item# PR11766

ORDER ONLINE! and Get FREE Software!

www.warehouse.com

Choose one of these software packages when you place an online order with MacWAREHOUSE!

*Limit one per customer \$3.95 shipping & handling. Shipped in promotional packaging. While supplies last.

Astra 600S Color Scanner

AS LOW AS **\$169.95!**

Adobe PhotoDeluxe and Presto! PageManager software.

- 30-bit single-pass color CCD
- 300 x 600dpi max 4800
- 8.5" x 14" legal scanner

Item# INP1145

100MB Zip Drives

ONLY **\$139.95!** Item# DRI 1050

100MB Zip Disks Ask for MED 0165

1-9	10-19	20+
\$19.99ea	\$16.99ea	\$12.99ea

Buy 10 Zip Disks get one FREE! Ask for BND2482. While supplies last!

Upgrade your G3

AS LOW AS **\$99.95!** with the latest DIMMs Now!

16MB upgrade for G3 PowerBook. Ask for Item# CHP0547 only \$99.95.

G3 Series!

Get a Furiously-Fast G3

For As Low As **\$1999!**



Price for Power Mac G3 Desktop/233MHz—Item# CPU0956, see below. Shown at right is Power Mac G3 Mini-tower/266MHz, only \$2999.

Hottest-selling Mac Ever!



Monitor sold separately.



Model shown is Power Mac G3/266MHz w/ZIP. Monitor sold separately.

UP TO **266MHz!**

The New Power Mac G3 Mini-tower Systems Feature:

- 233MHz or 266MHz PowerPC G3 processor
- 512K Level-2 backside cache
- 32MB-128MB RAM (expandable to 384MB)

- Power Mac G3 Mini-tower/233MHz/32MB RAM/4.0GB HD/24X CD/56K Modem: Item# CPU1105 **\$2149**
- Power Mac G3 Mini-tower/266MHz/32MB RAM/6.0GB HD/24X CD/ZIP Drive: Item# CPU0958 **\$2999**
- Power Mac G3 Mini-tower/266MHz/128MB RAM/4.0GB HD/Ultra-wide SCSI HD/24X CD/100Base-T Ethernet: Item# CPU1104 **\$4199**

Apple Power Mac G3 Desktop Systems

- 233 or 266MHz PowerPC G3 Processor
 - 512K Level-2 Backside Cache
 - 32MB RAM (exp to 192MB)
 - Built-in 10Base-T Ethernet
- Power Mac G3 Desktop/233MHz/32MB RAM/4.0GB HD/24X CD: Item# CPU0956 **\$1999**
 - Power Mac G3 Desktop/266MHz/32MB RAM/4.0GB HD/24X CD/ZIP Drive: Item# CPU0957 **\$2399**

New! Apple PowerBook G3

The FASTEST Notebook on the PLANET!

- 250MHz PowerPC G3 Processor
- 512K Level-2 Backside Cache
- 32MB RAM
- 5.0GB Hard Drive
- 20X CD-ROM Drive
- 33.6K Modem
- 12.1" Active-matrix display



Item# CPU0961 \$5699



New! Mac OS 8.1

Upgrade **\$69.95!**
Only

Item# SYS0280

*Price reflects publisher's \$30 mail-in upgrade rebate for previous owners of Mac OS 7.6. Proof of ownership of Mac OS 7.6 purchased separately or acquired through CPU purchase required.

Olympus D-320L High-Resolution Digital Camera

- Resolutions up to 1024 x 768
- 2MB Storage
- 2.0" LCD color monitor

Only **\$699!**

Accessories Kit includes: AC Adaptor and Vinyl Carrying Case. ACC 2978: \$119.95



Iomega 1.0GB JAZZ DRIVE!

As low as **\$199.95!**

Ask for Item# RDRI 1119. Internal Drives also available. Call for configurations.



Includes First 1.0GB Cartridge!



QuarkXPress 4.0

Only **\$699.95!**

Item# DTP0557 (Mac CD-ROM)

- Character-based style sheets
- Open up to 11 movable palettes for fast action and control
- Enhanced item and content tools
- Enhanced item and content tools



RIVEN The Sequel to MYST

Journey through vast, awe-inspiring landscapes but be forewarned, nothing is quite as it seems.

Only **\$49.95!**

Item# ENT1532

JAZZ CARTRIDGES

3.5" 1.0GB Cartridges
Ask for Item# MED0177

1-4 \$124.95ea 5-9 \$99.95ea 10+ \$89.95ea

Buy 7 Cartridges Get One FREE!
Price for 7 Cartridges: \$699
Ask for item# BND2411
While supplies last.

*Refurbished by the manufacturer to meet original factory specifications
†Jaz utility software included on first cartridge.

MacWAREHOUSE

To order, call toll-free 24 hours a day, 7 days a week

1-800-725-1450

Your #1 Source for Apple Products!

Circle 150 on reader service card



CALL TODAY FOR A **FREE CATALOG!**





MacConnection®

The Original Macintosh Mail-Order Source—Since 1984!

Order as late as 2:45 am. ET and STILL get Overnight Delivery!

Order Online: www.macconnection.com



Monitor sold separately

Small Business Powerhouse! Power Mac 6500/275

- 275MHz 603e
- 48MB RAM
- 6GB Hard Drive
- 24X CD-ROM
- Int. 100MB Zip
- 56Kbps



Includes **FREE MS Office!**

6500's Start At Only

\$1999

45745 Power Mac 6500/250 \$1999
(250MHz/32MB/4GB/24X/56K modem)

45750 Power Mac 6500/300 2999
(300MHz/64MB/6GB/24X/56K/100MB Zip Drive)

ONLY \$999

47973

Newest, Fastest Version!

Newton MessagePad 2100

Everything you want in a portable, without the bulk, weight and short battery life!

- 162MHz StrongArm SA-110 RISC processor
- 8MB ROM
- 8MB RAM (4MB DRAM, 4MB Flash)
- Built-in microphone and speaker

FREE

LunarLanding, SubPatrol and 2 WriteRights! (\$70 value)

24700 Newton Keyboard	79.95
45215 8MB Flash Memory Card FR	99.95
42405 Write Stuff	39.95
45215 8MB Flash Card FR	99.95
45220 16MB Flash Card FR	169.95

Microsoft

Upgrade Only

\$269.95

50177

NEW!

The Most Advanced Office Suite for Your Mac!

Microsoft Office 98 Macintosh Edition

- Cutting-edge versions of Microsoft PowerPoint, Outlook Express, Word, Excel & Internet Explorer!
- Familiar Mac appearance and behavior
- Advanced Internet technologies
- Automates everyday tasks
- Easy to install, easy to maintain!

Reserve Your Copy Today!

ORDER TODAY!

NEW! SoftWindows 95 V5.0
25% faster than the previous version!
Only **\$189.95**
50127

NEW! Mac OS 8.1 Update
New features, better performance!
FREE Only **\$99**
Allies to Bowling!
51370

NEW! QuarkXPress 4.0
FREE PhotoDisc Visual Symbols 2 (\$150 Value!)
Exclusive Bundle!
Only **\$689.95**
48275

NEW! FileMaker Pro 4.0
Upgrade/Trade-up
44990
Only **\$99**
Create powerful databases and take them to the web!

Peripherals!

Quicken Deluxe 98 & MacInTax 48658
NEW! Money-saving offer!
Buy Both Only **\$59*** Get more for your money in 98!
*After \$40 mfr.'s mail-in rebate

Canon BJC 4550 31539
NEW! low price!
Only **\$299**
• 720 x 360 dpi
• Prints up to 11" x 17"
• 5ppm b&w, 1ppm color

NEW! Expression 836XL 48104
Scanning made Epson easy!
Only **\$2499**

Kodak DC210 Zoom Digital Camera 46426
Zoom in, snap and preview! Kodak makes it easy to capture the detail you want!
Only **\$879**

Mitsubishi Diamond Pro 91TMX 21" 36276
Hi-res monitors for graphics and sophisticated applications!
Only **\$1299**

Kritter Camera 48982
NEW! The only full-motion zoom video camera for your PowerBook!
EXCLUSIVE! Only **\$299.95**

Zip® and Jaz® Blowout!

100MB Zip! While Supplies Last
Only **\$99.95***
47085 SCSI
47084 Parallel

1GB Jaz!
All factory warranties apply
49268 Jaz Intern
49269 Jaz Extern

Only **\$199.95*** Refurbished

Sportster 56K Faxmodem

The most affordable way to get 56K!
#1 Best-Selling Faxmodem!

- x2 technology nearly doubles the speed of ordinary 28.8 modems
- 56Kbps+download capability plus 28.8 and 33.6Kbps send and receive
- Universal connectivity
- Software upgradeable for easy updates
- FREE upgrade to ITU standard

Only **\$159.95*** 37317
*After \$30 mail-in rebate (expires 2/28/98)

7-Time Winner! Best Mail-Order

100

OUR POLICY • VISA, MASTERCARD, AMERICAN EXPRESS, and NOVUS cards. No surcharge. * Most products are covered by manufacturer's warranty against defects for at least 30 days from the invoice date. • All returns require prior authorization; please call for an RMA. • We are not responsible for typographical errors. • Pricing and promotions are subject to change without notice. Continental U.S. Shipping Charges: \$4.95 per order up to 3 pounds. On orders over 3 pounds, shipping is \$4.95 plus an additional \$1.25 per pound or fraction thereof. Please call for weight and pricing information. Items of excessive size and/or weight may require additional days to deliver via a freight carrier. Please check with your sales rep for more details. Barring events beyond our control, all credit card orders placed on weekdays by 2:45 a.m. ET will ship Airborne Express for delivery the next business day. Saturday delivery available to many areas upon request at no additional charge. Order all day Saturday thru noon Sunday for Monday delivery. Some areas require an extra day delivery. APO/FPO, International orders and Hawaii, Alaska, Canada, Puerto Rico & U.S. Virgin Islands. Shipping may require additional time and charges. All other areas: Call 603-446-4444 or FAX 603-446-7791 M-F 9 a.m.-6:30 p.m. ET. ©1997 PC Connection, Inc., Milford, NH. MacConnection & the raccoon characters are registered trademarks of PC Connection, Inc. All other trademarks remain the property of their respective companies.

G3's start as low as \$1999!

Apple's new super-fast Macs!



NEW!

Packed with high-performance features!

PowerBook G3/250

- 250MHz PowerPC G3 processor
- 32MB RAM (160MB max)
- 5GB Hard Drive
- 20X CD-ROM (max)
- 12.1" Active Matrix Color
- 512K L2 Backside Cache

G3
"The Fastest Laptop Yet!"
-Macworld 1/98

- 48162 Apple PowerBook G3/250 \$5699
(250MHz/32MB/5GB/20X)
- 35928 G3 PowerBook AC Adapter 49.95
- 48164 G3 Lithium Ion Battery 259.95



The New Benchmark in Computing!

Power Macintosh G3/266 Minitower 266MHz

- 266MHz G3
- 32MB RAM
- 6GB Hard Drive
- 24X CD-ROM
- 512K Backside Cache
- 100MB Zip Drive

Designed for Mac OS 8!

Mac OS 8

48160 **ONLY \$2999**



All monitors shown sold separately



G3 Power at an Incredible Price!

Power Mac G3/233

- 233MHz G3 Processor
- 4GB Hard Drive
- 2MB VideoRAM
- 32MB RAM
- 24X CD-ROM
- 66MHz System Bus

48158 **ONLY \$1999**

48159 Power Mac G3/266 \$2399
(266MHz G3/32MB/4GB/24X/100MB Zip)

Best Deals on Hardware & Software!

Utilities	
46532 Speed Doubler 8	\$54.95
44701 Real PC	79.95
40682 Norton Utilities Mac	97.95
32164 SAM v4.5	69.95
48715 Disk Drive TuneUp	59.95
48713 CD/DVD TuneUp	59.95
51658 Virex 5.8	59.95
49791 Hard Disk Toolkit 2.5	129.95
Graphics & Design	
41786 NetObjects Fusion	294.95
40314 Total Xaos Bundle	169.95
49822 Extensis Mask Pro	289.95
31756 Pantone HexWrench	299.95
47735 QuarkXPress 4 Mac	689.95
43868 Adobe Photoshop 4 Mac	539.95
43871 Adobe Illustrator 7 Mac	369.95
49193 Macromedia DreamWeaver	289.95
Business	
48658 Quicken Deluxe 98 and MacInTax	59*
*After \$40 combined mail-in rebates	
44771 Mac OS 8 upgrade	69

44990 FileMaker 4.0 upgrade	99
44778 ClarisWorks Office with FREE Star Trek ...69*	
*After \$30 upgrade mail-in rebate	
46286 MAC P&L	119.95
Games	
42144 Diablo	46.95
45697 Riven (Sequel to Myst)	49.95
45362 Myth	44.95
42119 Starfleet Academy	49.95
Personal Productivity	
46966 Tripmate for Mac	159.95
43723 Street Atlas USA 4.0 for Mac	42.95
44178 Reunion 5 upgrade from Reunion 4	39.95
24643 Learn to Speak Spanish	79.95
43258 Complete National Geographic Magazine - 108 years	169.95
Accessories	
39536 Kensington Orbit	69.95
32497 Masterlock Notebook Security Cable	39.95
25696 Mouse in the Box	39.95
33990 Solar Panel Mercury II	299.95

CD-ROM	
38365 La Cie Ext 2x6 CD-R Drive w/ Toast	399
38347 MDS 12X External SCSI CD-ROM	139.95
46415 Hi-Val Sountastic 24X CD-ROM	189.95
46412 MDS 24X External SCSI CD-ROM	169.95
Digital Cameras	
39582 Kodak DC120 Digital Zoom	799
45096 Ricoh RDC-300 Digital Camera	499
43512 Sandisk 20MB Compact Flash w/PCMCIA Adapter	279.95
43841 Fuji DX-5 Digital Camera	299.95
Video Cards & Accelerators	
44886 ATI Nexus GA	549
40281 Imagine 128 Ser2 8M PCI	799
37869 IMS Turbo TV PC & Mac TV Card	99
45169 MAXpowr Pro G3 250/512K	1099
40465 RenderPix 502-A	2949
Monitors	
43348 Hitachi MC7515-SS 19"	999
38305 Mag Innovation 710V2 17"	499
32695 Mag Innovation DX700T 17"	579
36276 Mitsubishi 91 TXM 21"	1299
39386 ViewSonic Optquest Q53 15"	269

Official Riven Solutions Guide

RIVEN THE SEQUEL TO MYST

In Stock! \$49.95

Only \$8.95

47662

45637

Storage

25447 Jaz 1GB SCSI Insider	299.95
24205 Jaz 1GB Single Disk	124.95
44384 Gig O' Color 10 pack	129.95
48947 Sylet 1.5 cartridge 3 pack	199.95
19867 Zip Disk 10-Pack	129.95

Printers

37819 Epson Stylus Color 600	249
37817 Epson Stylus Color 800	349
42275 Epson Stylus Color 3000	1999
40618 HP DeskJet 870Cse Printer	299
47066 HP LaserJet 4000N Printer	1449

FREE!

CALL TODAY!

or your FREE MacConnection or PC Connection catalog subscription!

Mention source code 498MW) **800-800-6924**

SUPER LOW SIMMS!

Memory as low as \$2.81 per MB

8MB as low as \$29.95

16MB as low as \$49.95

32MB as low as \$89.95

FREE SERVICE!

Custom Configured Systems

Call for details!

NEW!

Supplements the manufacturer's warranty for a full 4 years from date of purchase!

Start Saving Now!

ask about... **LEASING OPTIONS for BUSINESS**

CALL 800-800-0014

20,000 HOT PRODUCTS 24 HRS A DAY!

800-800-6924

www.macconnection.com

Secure Online Shopping!

498MW

ClubMac® GREAT DEALS ON ALL YOUR STORAGE NEEDS



ULTRASTAR ES 2.1GB

512K CACHE
5400 RPM
Internal

ONLY \$189

OUTSTANDING DEAL!



BARRACUDA 4XL 4.5GB

8.5MS Acc
7200 RPM
Internal

Quantum STRATUS SE
8.4GB \$499
512K Buffer Internal

Seagate CHEETAH
Fast & Wide
4.5GB \$699
10000 RPM Internal

Quantum VIKING
4.5GB \$389
7200 RPM Internal

Quantum ATLAS II
9.1GB \$749
7200 RPM Internal

NEW LOW PRICE

ONLY \$549!!

HARD DRIVES

Quantum

Description: Quantum Stratus drives carry a 3 Year Warranty
Quantum Atlas & Viking drives carry a 5 Year Warranty

Ultra SCSI-3 Model Access RPM Internal External

2.1GB Stratus SE	QM32160SES	10ms	5400	\$229	\$279
3.2GB Stratus SE	QM33240SES	10ms	5400	\$259	\$309
4.3GB Stratus SE	QM34320SES	10ms	5400	\$299	\$349
4.5GB Viking	QM34550VKS	8ms	7200	\$389	\$439
4.5GB Atlas II	QM34550ALS	8ms	7200	\$499	\$549
6.4GB Stratus SE	QM36480SES	10ms	5400	\$389	\$439
8.4GB Stratus SE	QM38420SES	10ms	5400	\$499	\$549
9.1GB Atlas II	QM39100ALS	8ms	7200	\$749	\$799

UltraWide SCSI-3

4.5GB Viking	QM34550/KSW	8ms	7200	\$399	\$479
4.5GB Atlas II	QM34550/ALW	8ms	7200	\$519	\$599
9.1GB Atlas II	QM39100/ALW	8ms	7200	\$779	\$859

IDE Drives

2.1GB Stratus SE	QM32160SEA	10ms	4500	\$159	----
3.2GB Stratus SE	QM33240SEA	10ms	4500	\$189	----
4.3GB Stratus SE	QM34320SEA	10ms	4500	\$219	----
6.4GB Stratus SE	QM36480SEA	10ms	4500	\$299	----



Ultra SCSI-3

Seagate drives carry a 5 Year Warranty

4.5GB Barracuda 4XL	ST34572N	8.5ms	7200	\$549	\$599
4.5GB Cheetah	ST34501N	8ms	10000	\$649	\$699
9.1GB Barracuda 9	ST19171N	8ms	7200	\$779	\$829
9.1GB Cheetah	ST19101N	8ms	10000	\$1029	\$1079

UltraWide SCSI-3

4.5GB Barracuda 4XL	ST24572W	8.5ms	7200	\$579	\$659
4.5GB Cheetah	ST34501W	8ms	10000	\$699	\$779
9.1GB Barracuda 9	ST19171W	8ms	7200	\$829	\$909
9.1GB Cheetah	ST19101W	8ms	10000	\$1029	\$1109

Fast SCSI-2

23GB Elite 23	ST423451N	8ms	5400	\$1799	\$1899
---------------	-----------	-----	------	--------	--------

Fast&Wide SCSI-2

23GB Elite 23	ST423451W	8ms	5400	\$1859	\$1959
---------------	-----------	-----	------	--------	--------

IBM HOT DRIVE OFFER!!!

2.1GB UltraStar ES	09J1034	8.5ms	5400	\$189	\$239
--------------------	---------	-------	------	-------	-------

THE CLUBMAC PACKAGE

ClubMac drives are preformatted and thoroughly tested. ClubMac drives include a 30-Day Money Back Guarantee, Charismatic Anubis Formatting Utility software, user's guide, brackets (wide drives include internal ribbon cable), 25/50-pin SCSI cable and power cord for external drives (wide drives include 68/68 pin SCSI cable).

TAPE BACK-UP

ClubMac DDS-3 DAT Drive

12-24GB
\$1199



CLUBMAC TAPE BACK-UP

4-8GB DDS-2 Compression DAT Drive	\$799
4-8GB DDS-2 Performance DAT Drive	\$899
12-24GB DDS-3 Lightning DAT Drive	\$1199
15-30GB DLT Drive w/ Retrospect	\$2599
20-40GB DLT Drive w/ Retrospect	\$2999

ClubMac 8mm AIT Drive

25-50GB
Up to 6MB/Sec!
ONLY \$3099



CLUBMAC AIT DRIVE

25-50GB 8mm AIT Drive \$3099

BONUS OFFER!!!

All ClubMac Tape Back-up Products are bundled with Retrospect 4.0

RETROSPECT 4.0

Retrospect 4.0 Retail Single User	\$149
Retrospect 4.0 Remote 10 User License	\$175
Retrospect Network Kit 4.0 (w/10 User License)	\$275

REMOVABLE

\$299



REMOVABLE DRIVES

ClubMac SyQuest 200MB 5.25"	\$349
SyQuest EZ Flyer 230MB 3.5"	\$149
SyQuest SyJet 1.5GB 3.5"	\$299
Nomai 750MB 3.5"	\$285

SYQUEST MEDIA

Media	Qty 1	Qty 10	Qty 20
44MB	\$38ea	\$37 ⁹⁹ ea	\$37ea
88MB	\$38ea	\$37 ⁹⁹ ea	\$37ea
200MB	\$59ea	\$58ea	\$57ea
270MB	\$43ea	\$42ea	\$41ea
EZ230MB	\$27ea	\$26 ⁹⁹ ea	\$26ea
1.5GB SyJet	\$69ea	\$68ea	\$67ea

CD READERS & RECORDERS

BLAZING FAST!

32X CD-ROM

ONLY \$179



CLUBMAC CD-ROM READERS

12X 140ms 1800k/sec	\$129
32X 90ms 5400k/sec	\$179
16X 5 Disc CD Changer	\$279

THE CLUBMAC PACKAGE:

ClubMac CD-ROM & CD Recorders are thoroughly tested. CD-ROM & CD Recorders include a 30-Day Money Back Guarantee, Charismatic CD AutoCache utility software, user's guide, 25/50-pin SCSI cable, terminator, and power cord.

ClubMac NEW! \$499!!

4X/12X CD Recorder



CLUBMAC CD-RECORDERS

4X/8X CD-R w/Toast Pro 3.5	\$249
4X/12X CD-R w/Toast Pro 3.5	\$299
CLUBMAC CD-REWRITABLE	\$249
2X/2X/6X CD-RW w/Toast Pro 3.5	\$249
4X/2X/6X CD-RW w/Toast Pro 3.5	\$299

Zip Drive Solutions

Includes One Free Cartridge

ZIP DRIVE ONLY \$139⁹⁵

100MB

\$199⁹⁵

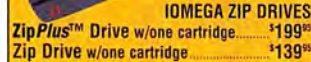

IOmega ZIP DRIVES

ZipPlus™ Drive w/one cartridge	\$199 ⁹⁵
Zip Drive w/one cartridge	\$139 ⁹⁵
Zip Bundle - drive, 11 Disks, Case, 2 Caddy's	\$279
Zip Drive Internal - all PowerMacs	\$159
Zip Drive Internal - all PowerComp./Umux	\$139

Jaz Drive Solution

Includes One FREE Cartridge

ONLY \$299⁹⁵

1.0GB



IOmega JAZ DRIVES

Jaz Drive w/one cartridge	\$299
ClubMac Jaz Drive w/three cartridges	\$499
Jaz Drive Internal - all PowerMacs	\$299
Jaz Drive Internal - all PowerComp./Umux	\$279

IOmega JAZ AND ZIP MEDIA

FREE CAMERA!!!



CALL NOW LIMITED TIME OFFER!

ZIP MEDIA

Format	Part#	Qty 1-2	Qty 3-5	Qty 7-9	Qty 10+
MAC	1040 1006	\$19 ⁹⁵	\$16 ⁹⁵	\$14 ⁹⁵	\$12 ⁹⁵
PC	1040 1009	\$19 ⁹⁵	\$16 ⁹⁵	\$14 ⁹⁵	\$12 ⁹⁵

JAZ MEDIA

Format	Part#	Qty 1-2	Qty 3-5	Qty 7-9	Qty 10+
MAC	1040 1015	\$124 ⁹⁵	\$99 ⁹⁵	\$88 ⁹⁵	\$88 ⁹⁵
PC	1040 1037	\$124 ⁹⁵	\$99 ⁹⁵	\$88 ⁹⁵	\$88 ⁹⁵

CALL 1-800-260-5109 FOR A FREE CATALOG

WARRANTIES: All items manufactured by ClubMac are returned to ClubMac for warranty repair. All other items carry manufacturer warranty. MONEY BACK GUARANTEE: All products manufactured by ClubMac carry a 30 day money back guarantee. ClubMac's all other manufacturers' return policies to its customers. Non-ClubMac products carry 30 day money back guarantee when shipped. RETURNS: Call for RMA number! Any product that is returned WITHOUT an RMA number will be refused. ALL PRODUCT INFORMATION AND PRICES ARE SUBJECT TO CHANGE WITHOUT NOTICE. NOT RESPONSIBLE FOR TYPOGRAPHICAL ERRORS.

FREE SCANNER WITH MOST UMAX SYSTEMS

CANVAS 5.0 WITH ALL APPLE SYSTEMS



PRICE SLASHED ~~1999~~
\$1878
 ONLY!
 Sky diving

PowerMac G3

- 233MHz PowerPC™ G3 Processor
- 133MHz dedicated 64-bit backside bus
- 512K L2 backside cache on processor
- 66MHz system bus
- 32MB RAM
- 4MB ROM
- 24X CD ROM Drive

Macintosh® PowerBook 3400

- 12.1" Active Matrix Display
- 200MHz 603e
- 2GB Hard Drive
- 6X CD ROM
- 33.6 Modem
- 1DBT Ethernet



JUST \$2999

Monitor sold separately.
FREE CANVAS 5.0
 W/ APPLE CPU. \$379 VALUE!
*Shipped in promotional package. Ask for Part Number PPP 1008

FREE CANVAS 5.0
 W/ APPLE CPU. \$379 VALUE!
*Shipped in promotional package. Ask for Part Number PPP 1008

PowerMac G3 266MHz G3 Desktop 32MB RAM, 4GB HD, 24X CD	\$2278
PowerMac G3 233MHz G3 MiniTower 32MB RAM, 4GB HD, 24X CD, Zip Drive, 56K Modem	\$2045
PowerMac G3 266MHz G3 MiniTower 32MB RAM, 4GB HD, 24X CD, Zip Drive, 24-Bit Video	\$2848
PowerMac G3 Super 266 G3 MiniTower 128MB RAM, 4GB UFW HD, 24X CD, Zip Drive, 100BT Ethernet, Whisper 128bit w/ 8MB VRAM	\$3991

PowerBook 3400 240MHz 603e, 16MB RAM, 3GB HD, 12X CD, 12.1" Active Matrix, 33.6 Modem	\$4263
--	--------

FREE CANVAS 5.0

PowerMac 9600

- 300MHz 604e
- 64MB RAM
- Zip Drive
- 24X CD ROM

JUST \$3597

FREE CANVAS 5.0

Macintosh PowerBook 1400CS

- 11.3" Dual Scan
- 166MHz 603e
- 1.3GB Hard Drive
- 12X CD Rom

JUST \$1634

FREE CANVAS 5.0

Macintosh PowerBook G3

- 250MHz PowerPC™ G3
- 50MHz System Bus
- 12.1" Active Matrix
- 20X CD Rom
- 32MB EDO RAM
- 56B IDE Hard Drive

JUST \$5425

FREE CANVAS 5.0

PowerMac 9600 300MHz 604e

32MB RAM, 4GB HD, 24X CD, Zip

\$3597

FREE CANVAS 5.0

PowerBook 1400CS 166MHz 603e

16MB RAM, 1.3GB HD, 12X CD, 11.3" Dual Scan

\$1634

FREE CANVAS 5.0

PowerBook G3 250MHz

32MB RAM, 5GB HD, 20X CD, 12.1" Active Matrix

\$5425

Special Price 20" MONITOR ONLY
MSF2 Monitor
 Viewable Area

\$999!

GRAPHIC CARDS

Nexus GA 8MB

ONLY \$529

MODEMS

56K Sportster Data Fax/Modem

ONLY \$167.99

SOFTWARE

Quark 4.0

IN STOCK! \$699

FREE CANVAS 5.0

PowerMac 6500

- Up to 300MHz 604e • 24X CD
- Up to 64MB RAM • Zip (except 250 MHz)
- 56K Modem
- Up to 6GB HD

Starting at \$1399

MONITOR

can 100ES 15", 1280x1024, 25mm

can 100GS 15", 1280x1024 on screen disp.

can 200ES 17", 1280x1024, 25mm

can 200GS 17", 1280x1024 on screen disp.

can 205SF 20", 1280x1024

can 300SF 20", 1280x1024

can 400PS 19", 1600x1200

can 500PS 21", 1600x1200

ACCELERATORS

MAXPower G3

PowerPC 750 Upgrade

250MHz for just \$899

SCANNERS

VISIONEER PAPERPORT Strobe

SPECIAL \$199

PRINTERS

AMAZING EPSON QUALITY! UNBELIEVABLE PRICES!

STYLUS \$249

SUPERMAC \$900 UMAX

- 200MHz 604e
- 32MB RAM
- 8X CD ROM
- 2.1GB SCSI HD
- IMS Video 4MB VRAM

\$1995

FREE Astra 610S SCANNER
 W/ EVERY UMAX CPU PURCHASE!

UPGRADE YOUR MEMORY TODAY!

PowerMac G3 DIMMS

4MB	\$20	\$19
8MB	\$35	\$34
16MB	\$60	\$59
32MB	\$119	\$118

PowerBook Memory 3400 SERIES

4MB	\$8	\$8
8MB	\$15	\$15
16MB	\$29	\$29
32MB	\$55	\$55

NEWER TECHNOLOGY

MAXPower G3 6100/240MHz/160

MAXPower G3 7100/6100 210MHz/105

MAXPower G3 7100/6100 240MHz/125

MAXPower G3 275/183 PPC 750 upgrade

MAXPower G3 275/183 PPC 750 upgrade

MAXPower G3 275/275 PPC 750 upgrade

NUPower 1400 183MHz PPC upgrade

VISIONEER PAPERPORT Strobe

Price after \$50 mail-in rebate. Ends 3/31/98

Agfa SnapScan 310 30 bit Scanner \$199

Agfa Arcus II Desktop Pro Scanner \$1499

UMAX Astra 610S \$129

UMAX Powerlock II w/trans. adapter \$1195

Microtek Scanmaker III w/trans adapter \$1389

Microtek Scanmaker EG w/Photoshop \$1469

Microtek Scanmaker V310, 30bit \$119

PRINTERS

EPSON Stylus Color 600 1440 DPI \$249

EPSON Stylus Color 800 1440 DPI \$349

EPSON Stylus Color Photo 6 COLOR \$399

EPSON Stylus Color 3000 17x22 1440 DPI \$1999

HEWLETT PACKARD HP LaserJet GIMP \$885

HP DeskJet 870CXI \$389

ClubMac

Source Code 690498

ORDER TODAY! 24 HOURS A DAY 7 DAYS A WEEK

1-800-260-8549

Order On-line @ <http://www.club-mac.com>

WE WILL TRY TO MATCH OR BEAT ANY ADVERTISED PRICE. CALL FOR LATEST PRICING!!

WE ACCEPT PO'S FROM QUALIFIED FIRMS

M E M O R Y

SECURITY WILL CALL WINDOW NOW OPEN!
NO SURCHARGE FOR MC, VISA AE & DISCOVER

L.A. Trade has served the PC market for 10 years...

MACINTOSH MEMORY UPGRADES

Now we bring our expertise to the Apple Macintosh user.

YOUR MACHINE	STANDARD	MAX	VIDEO UPGRADE	VIDEO COST	256K/512K/1MG CACHE	2MB	4MB	6MB	8MB	10MB	12MB	16MB	20MB	24MB	32MB	48MB	64MB	128MB		
Apple PowerBook G3									59			79		139	139	189	239	499		
Apple PowerBook 165C, 180C							105	154	189	239										
Apple PowerBook 165, 180							105	154	189	239										
Apple PowerBook 190, 190CS									55											
Apple PowerBook 520, 520c, 540, 540c Notebook	4/8	36/40							40			85				149				
Apple PowerBook DUO 210, 230, 250 Notebook	4	36					40	55	34	75	79	89	109	28+139						
Apple PowerBook DUO 270c Notebook	4	32					40	55	34	75	79	89	109	28+139						
Apple PowerBook DUO 280, 280c Notebook	4	40					40	55	34	75	79	89	109	28+139	36+279					
Apple PowerBook DUO 2300c/100 Notebook	8/20	56							34	75	79	89		129	179	269				
Apple PowerBook 1400	12/16	60/64							69					119	169	229				
Apple PowerBook 2400	16	80							49					99			419			
Apple PowerBook 3400C EDO	16	144							50					89		139	139	189	239	499
Apple PowerBook 5300 Series	8/16/32	56/64					49				69	79			149	159	219			
Apple Macintosh IIfx (64 pin)	4	128								119								356		
Apple Macintosh IISI	2/3/5	17								28										
Apple Macintosh IIfx & IIfx	4	68	512k	59															356	
Apple Macintosh Classic II, LC, LCII	2/4	10	512k	59		16														
Apple Macintosh LCIII, LC475, LC550, LC575, LC580	4	36	256k	34			15		34										99	
Apple Macintosh LC520	5	36					15		34										99	
Apple Macintosh LC580	4	48					15		34										99	
Apple Macintosh LC499	4	36					15		34										99	
Apple Macintosh LC5200	8	64					15		34										99	
Apple Macintosh LC630	5	36					15		34										99	
Apple Macintosh IIfx	1/5	128								40					119			208	356	
Apple Macintosh II, IIfx, IIfx (w/Pal)	1	32								48					149			298		
Apple Macintosh SE30	1/2	32								40					119			238		
Apple Performa 400	4	10	512k	68		22	30		56											
Apple Performa 405, 410, 430	4	10	512k	68		22	30		56											
Apple Performa 450, 460, 466, 467, 475, 476	4	36	256k/512k	34/68			15		34						99				99	
Apple Performa 550, 560, 575, 577, 578, 580	5	36	256k	34			15		34						99				99	
Apple Performa 600, 600CD	5	68	512k	59			40												356	
Apple Performa 6110CD, 6112CD, 6115CD (pairs)	8/16	72					15		34						49				99	
Apple Performa 6117CD, 6118CD (pairs)	8/16	72					15		34						49				99	
Apple Performa 630, 630CD, 636	4	36					15		34						49				99	
Apple Performa 631CD, 636CD, 640CD	8	52					15		34						49				99	
Apple Performa 635CD	5	36					15		34						49				99	
Apple Performa 637CD, 638CD	8	36					15		34						49				99	
Apple Performa 5200 Series 5200CD, 5215CD, 5300	8/16	64					15		34						49				99	
Apple Performa 6100 Series 6116CD (pairs)	8/16	72					15		34						49				99	
Apple Performa 6200 Series 6200CD, 6216CD, 6218CD	8	64					15		34						49				99	
Apple Performa 6200 Series 6220CD, 6230CD, 6290	8	64					15		34						49				99	
Apple Performa 6205CD, 6214CD	8	64					15		34						49				99	
Apple Performa 6300CD, 6320	16	64					15		34						49				99	
Apple Performa 6400CD, 6360 (2K Refresh)	16	136			94										49				149	
Apple Centris 610, 650, 660 AV	4	132	512k	59			15		34						49				99	
Apple Quadra 605	4	36	512k	59			15		34						49				99	
Apple Quadra 610	4	68	256k	34			15		34						49				99	
Apple Quadra 630	4	36					15		34						49				99	
Apple Quadra 650	4/8	132/136	256k	34			15		34						49				99	
Apple Quadra 660AV	4	68					15		34						49				99	
Apple Quadra 700	4	68	256k	34			48								104				356	
Apple Quadra 800 (pairs)	8	136	512k	59			15		34						49				99	
Apple Quadra 840AV	8	128	512k	59			15		34						49				99	
Apple Quadra 900	4	256	512k	59			48								104				356	
Apple Quadra 950	8	256	512k	49			48								104				356	
Power Macintosh G3			2/4/6M	3369/Call						49					69			99	319	719
Power Macintosh 4400/160	8	72	2M/4M	59/79			89/119/-								53				99	149
Power Macintosh 5200, 5260, 5300	16	136					89/119/-			15					49					99
Power Macintosh 5400	8	136					89/119/-								53					99
Power Macintosh 6100/60, 6100/66, 6100/66AV (pairs)	8/16	72					29/-/-			15					49					99
Power Macintosh 6200/75	8/16	72					29/-/-			15					49					99
Power Macintosh 6400/200	8/16	72					89/119/-								53					149
Power Macintosh 6500/225, /250, /275, /300 (Edo)	8/16	72					29/-/-			15					53					149
Power Macintosh 7100/66, 7100/80, 7100/66AV (pairs)	8/16	136	512k	59			29/-/-			15					49					99
Power Macintosh 7200/75, /90, /120, /120PC	8/16	256	1mg	49			49/74/169								53					149
Power Macintosh 7300/166, /180, /200, 7500/100	8/16	256/1gig	1mg	49			49/74/169								53					149
Power Macintosh 7600/100, /120, /132, /200	8/16	1gig/512	1mg	49			49/74/169								53					149
Power Macintosh 8100/80, /100, /110	8/16	264	512k	59			29/109			15					49					99
Power Macintosh 8100/80AV, /100AV, /110AV (pairs)	8/16	264	512k	59			29/109			15					49					99
Power Macintosh 8500/120, /132, /150, /180	8/16	1gig/512	1mg	29			49/74/169								53					149
Power Macintosh 8600/200, /233	8/16	1gig/512	1mg	49			49/74/169								53					149
Power Macintosh 9500/120, /132, /150, /180MP, 200	16/32	768/1.5 gig	2mg	62											53					149
Power Macintosh 9600/200, /233, /200MP	8/16	768	2mg	87											53					149
Color Laserwriter 12/600 PS	12	40								16					49					
Color Laserwriter 12/640 PS	4	64								16					49					89
Color Laserwriter 16/600 PS	8	32								16					49					209
Motorola Starmax 3000 EDO/160, 200, 4000/160, 200	16/32														74					99

ORDER ON LINE & RECEIVE A FREE GIFT!
Orders of \$100 or more receive a gift worth \$19.95
Orders of \$500 receive a gift worth \$39.00
www.4LATrade.com

NEW 168 Pin EDO 3.3V Dimms Call!

UMAX MEMORY

C500/140, 160, 180	8/16/32/64 meg	37/53/99/189
C600/180, 200, 240	8/16/32/64 meg	37/53/99/189
J700/150, 180	8/16/32/64	37/53/99/189
S900/150, 180, 200, 225 (pairs)	8/16/32/64/128 meg	37/53/99/189/569
S900 dp/180, 200 (pairs)	8/16/32/64/128 meg	37/53/99/189/569

HOT BOX SPECIALS - LIMITED QUANTITIES

Apple Powerbook Duo	8Meg	21.00
Apple Powerbook Duo	4Meg	9.00
Apple Powerbook Duo	4Meg	19.00
Apple Powerbook 5300	8/12/15Meg	29/39/59
Apple Powerbook Duo 230	16Meg	69.00
Apple Powerbook Duo 230	14Meg	49.00

CHECK OUT OUR WEBSITE FOR APPLE BATTERIES!!!

CALL FOR NEW MODELS NOT LISTED

All products brand new & guaranteed • We buy excess inventory
Trademarks are registered with their respective companies.



22825 Lockness Avenue • Torrance, CA 90501
CUSTOMER SERVICE & TECHNICAL: OPEN M-F, 9-4 PST

POWER COMPUTING

POWER 80, 100, 110, 120	8MEG	16 MEG	32MEG	64MEG
POWER CENTER 120, 132, 150, 166, 180	37.00	55.00	99.00	189.00
POWER CURVE 601/120	37.00	55.00	99.00	189.00
POWER TOWER 166/180	37.00	55.00	99.00	189.00
POWER TOWER PRO 180, 200, 225	37.00	55.00	99.00	189.00
POWER WAVE 604/120	37.00	55.00	99.00	189.00
POWER WAVE 604/132, 150	37.00	55.00	99.00	189.00
POWER COMPUTING POWER BASE (EDO)	44.00	74.00	119.00	209.00

NO SURCHARGE FOR MASTERCARD, AMEX, VISA OR DISCOVER. PURCHASE ORDERS ACCEPTED FROM JUNE 2000. GOVERNMENT & INSTITUTIONS. California orders add 8.25% sales tax. Returned orders or ordered wrong parts are subject to a 20% restocking fee. We accept international orders shipped via UPS Air, APO, FPO orders welcome. Customers are expected to pay customs and "other" charges if shipped Int'l. All credit card charges verified for fraudulent use. SORRY, NO REFUNDS AFTER 30 DAYS - EXCHANGES ONLY. If you receive defective merchandise we exchange only—no refunds. We accept MC, VISA, Discover, AE, prepaid orders, purchase orders, wire transfer, C.O.D. (cashiers check) orders, cash & cashiers checks. Orders shipped by UPS. FEDEX must be signed for. *ALL MANUFACTURER PART #'S ARE FOR REF. ONLY • MINIMUM ORDER \$40.00 • NO REFUNDS ON SHIPPING.

310-539-0019
FAX: 310-539-5844

SECURITY WILL CALL WINDOW NOW OPEN

CALL TOLL FREE



The LLB Company, Inc.

1-800-848-8967



Website: www.llb.com International: 425.746.0229 Fax: 425.746.5168

DESKTOP MEMORY UPGRADES

168-PIN SDRAM			168-Pin DIMMs			EDO 3.3V 60ns DIMMs			EDO 5v 60ns DIMMs			72-Pin SIMMs			30-Pin SIMMs		
G3 Systems			PowerMac Series-60ns			Starmax & Pm 4400			Power Base Series			PowerMac 6100...			Mac IICI, si, se, IICx...		
Module	Item#	Price	Module	Item#	Price	Module	Item#	Price	Module	Item#	Price	Module	Item#	Price	Module	Item#	Price
128MB	128664SD	\$519	128MB	128664	\$644	64MB	64764EDO3.3V	\$165	64MB	64764EDO5V	\$165	32MB	32632	\$79	16MB	1601	\$115
64MB	64764SD	\$219	64MB	64764	\$152	32MB	32764EDO3.3V	\$80	32MB	32764EDO5V	\$80	16MB	16732	\$43	8MB	8888	\$42
32MB	32764SD	\$77	32MB	32764	\$82	16MB	16764EDO3.3V	\$40	16MB	16764EDO5V	\$40	8MB	8032	\$23	4MB	4000	\$18
16MB	16764SD	\$69	16MB	16764	\$45	8MB	8764EDO3.3V	\$37	8MB	8764EDO5V	\$37	4MB	4032	\$18	2MB	2000	\$16

POWERBOOK MEMORY UPGRADES

POWERBOOK G3			POWERBOOK 3400			POWERBOOK 2400			POWERBOOK 2300			POWERBOOK DUO			POWERBOOK 190		
Module	Item#	Price	Module	Item#	Price	Module	Item#	Price	Module	Item#	Price	Module	Item#	Price	Module	Item#	Price
128MB	PB3400-128G3	\$425	128MB	PB3400-128	\$439	64MB	PB2400-64	\$382	48MB	PB2300-48	\$288	36MB	PB2300-36	\$245	32MB	PB190-32	\$155
64MB	PB3400-64G3	\$230	96MB	PB3400-96	\$399	32MB	PB2400-32	\$186	36MB	PB2300-36	\$245	28MB	PB2300-28	\$239	16MB	PB190-16	\$116
32MB	PB3400-32G3	\$119	64MB	PB3400-64	\$236	24MB	PB2400-24	\$153	32MB	PB2300-20	\$205	20MB	PB2300-20	\$139	12MB	PB190-12	\$70
16MB	PB3400-16G3	\$78	32MB	PB3400-32	\$119	16MB	PB2400-16	\$93	20MB	PB2300-16	\$162	14MB	PB2300-14	\$115	8MB	PB190-8	\$65
			24MB	PB3400-24	\$145	4MB	PB2300-4	\$40	16MB	PB2300-16	\$118	12MB	PB2300-12	\$109			

POWERBOOK 5300			POWERBOOK 1400			POWERBOOK 500			POWERBOOK 150		
Module	Item#	Price	Module	Item#	Price	Module	Item#	Price	Module	Item#	Price
48MB	PB5300-48	\$205	24MB	PB1400-24	\$117	32MB	PB500-32	\$88	28MB	PB150-28	\$219
32MB	PB5300-32	\$95	16MB	PB1400-16	\$89	16MB	PB500-16	\$49	20MB	PB150-20	\$160
16MB	PB5300-16	\$77	8MB	PB1400-8	\$60	8MB	PB500-8	\$45	8MB	PB150-8	\$70
8MB	PB5300-8	\$65				4MB	PB500-4	\$40	4MB	PB150-4	\$45

V-RAM

2MB G3 SGRAM	\$48
4MB G3 SGRAM	\$60
1MB V-RAM (DIMM)	\$27
2MB V-RAM (DIMM)	\$72
2MB Motorola	\$25
4MB Motorola	\$55
256K 80NS	\$15
512K V-RAM	\$22

PRINTERS & SCANNERS



UMAX
Computer Corporation

Astra 1200

\$248

Astra 610s \$148
Astra 1200 w/Full PS & Trans \$579



EPSON

Stylus 600 Inkjet **\$319**

Stylus 800 Inkjet \$399
Expression 636 Executive \$805
Stylus Color 1520 \$807
Stylus Color 3000 **IN STOCK \$1922**

HEWLETT PACKARD

Laserjet 6MP 600 DPI \$927
Laserjet 4000 17PPM \$1139

MODEMS



GLOBAL VILLAGE COMMUNICATION

As Low As \$159

Teleport 56 K56 Flex Ext	\$159
Teleport 56K X2 Ext	\$157
Powerport 56k PCMCIA/Enet	\$388

DIAMOND

SUPRA Express 56e K56 Flex Sp	\$149
SUPRA Express 56e K56 Flex Ext	\$137
SUPRA Express v.34 Ext 14.4 S/R	\$89

Robotics

Sportster 56K X2 Ext Fax	\$195
Sportster 33.6 Ext w/voice(14.4 Fax)	\$128
Sportster 56K XJack PCMCIA	\$228

MONITORS



NEC

HOT!

NEC LCD 2000 20" \$7786
NEC M500 15" Multisync \$389
NEC E500 15" Multisync \$404

SONY

CPD 200ES 17" \$649
CPD 100ES 15" \$359

ViewSonic

G800 20" \$1089
E655 15" \$274

UMAX SUPERMAC SYSTEMS

Computer Corporation

STATE OF THE ART PERFORMANCE WITH AFFORDABLE PRICING!

SuperMac	Processor/Speed	
UCC 500L-200LT	603E 200MHz (LT)	\$997
UCC 600L-240LT	603E 240MHz (LT)	\$1397
UCC 600L-200	603E 200MHz	\$1195
UCJ 700L-180	603E 180MHz	\$1775
UCJ 700L-233	604E 233MHz	\$1945
UCS 900L-200	604E 200MHz	\$2435
UCS 910E-250	604E 250MHz (E)	\$4246
UCS 910E-250D	604E 250MHz (DP)	\$6759



Jaz 2 Drive with 1 Free Disk

\$634

Zip Drive w/Disk \$149

newer tech

Add G3 Power with the NEW Maxpowr Series

For the PowerMac 6100 Series	
Maxpowr G3 210MHz/512K Cache	\$496
Maxpowr G3 240MHz/1MB Cache	\$680
For the PowerMac 71/8100 Series	
Maxpowr G3 210MHz/512K Cache	\$580
Maxpowr G3 240MHz/1MB Cache	\$778
For the PowerMac 72/75/85/9500..	
Maxpowr G3 275MHz/512K Cache	\$2110
For the PowerBooks.....	
PB1400 Nupowr 183MHz CPU	\$477
PB500 Nupowr 183MHz 24MB	\$869

DRIVES

LACIE

Q 2.1 GB (Ext) 5400RPM	\$332
Q 4.3 GB (Ext) 5400RPM	\$418
Q 6.4 GB (Ext) 7200RPM	\$538
Q 9.1 GB (Ext) 7200RPM	\$919
LaCie 24X Ext CD-Rom Drive	\$199

1-800-848-8967

Electronic Orders: E-Mail: sales@llb.com · Web Site: www.llb.com · PO's are accepted upon approval

· All major credit cards accepted and charged when order is shipped · No surcharge on credit cards · Prices subject to change
· Open 6am to 7pm M-F, 8am to 1pm Sat. PST · Returns subject to restocking fee · Not responsible for errors · We welcome International orders
· Orders received before 8:00p.m. EST weekdays shipped same day

PROUDLY SERVING MAC USERS SINCE 1986

Now tightly integrated with Mac OS 8!

Microsoft Office 98 Macintosh Edition Upgrade

NEW!



ONLY \$264⁹⁸
#55870

Microsoft Office 98 Macintosh Edition

Turns your Mac into a FAST, functional PC!



SoftWindows 95 5.0 Upgrade CD

ONLY \$95⁹⁸
#72589

INSIGNIA SOLUTIONS.

Grab more creative power!

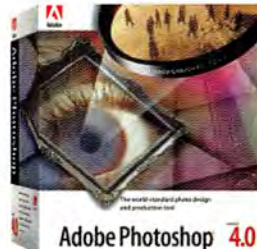

Photoshop 4.0.1 Upgrade

ONLY \$169⁹⁸
#83084

Adobe

The standard in automated graphics production!



NEW UPGRADE!

Debabelizer 3

ONLY \$149⁹⁸
#77500

EQUILIBRIUM
The Art of Automation™

PRICE DROP! WAS \$2499

NOW ONLY \$1999

#74700



SAVE \$500 on this 4.4 pound portable!

Apple® Macintosh® PowerBook® 2400c/180MHz

- 180MHz PowerPC™ 603e processor
- 16MB RAM, expandable to 48MB
- 1.3GB hard drive
- 256K Level 2 cache
- Brilliant 10.4" active-matrix SVGA display supports thousands of colors
- Graphics acceleration and Zoomed Video support

Web savvy, auto effects, publishing ease & more!

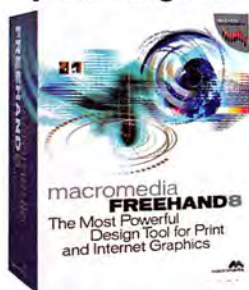

NOW SHIPPING!

FreeHand 8 Upgrade

ONLY \$148⁹⁸
#84242

Design Web Sites with the tool of your dreams!

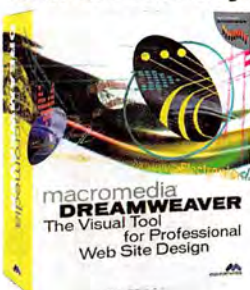

Dreamweaver

ONLY \$298⁹⁸
#73486

macromedia

The affordable way to shoot digital video AND photos!

Grayscale QuickCam for Macintosh

ONLY \$69⁹⁸
#72574



All the positives with no negatives!



OLYMPUS

Digital Camera D320-L

ONLY \$699⁹⁸
#50570

The mainstream business and graphics scanner!

Astra 1200s Flatbed Scanner with PhotoDeluxe & PageManager

ONLY \$249⁹⁸
#77119

UMAX
The Magic of Color™



SPECIALIZED SERVICE

Corporate Sales 1-800-258-0882
Government Sales 1-800-372-9663
Education Sales 1-800-381-9663

THE MAC ZONE • TRUSTED INTERNATIONALLY

Austria • Chile • Colombia • Denmark • France • Germany • Holland • India
Israel • Italy • Japan • Kenya • Mexico • New Zealand • Norway • Poland
Portugal • Singapore • Spain • Sweden • Switzerland
United Arab Emirates • United Kingdom • Venezuela

International Sales 1-425-430-3570

Copyright © 1998
The Mac Zone®
is a registered trademark
of Multiple Zones International,
Inc. All rights reserved.



We Carry the Full Line of Apple® Macintosh® Computers

- Over 6000 Products to Choose From!
- Cool Bundles and Hot Specials!
- Low Prices Everyday!
- Overnight Delivery only \$3 (up to 2 lbs)

we're open
24 hours a day
7 days a week



Fast color printing for today's networked office!

HP DeskJet 870Cse Printer

ONLY \$299⁹⁸
 #36156



The ideal solution for high-volume workgroup printing!

Apple® LaserWriter® 8500

ONLY \$1999
 #74757



Everything a Zip® drive has... and more!

ZipPlus 100MB Removable Media Drive

Includes one FREE Zip disk!



ONLY \$199⁹⁵
 #52581

#91825 Iomega Zip 100MB Drive.....\$138.95

16MB DIMMS

AS LOW AS

\$109⁹⁸

CALL FOR LATEST PRICES ON MEMORY.



The new Short Depth is here!

NEW!

ViewSonic®
 See The Difference!™

GS771 17" Monitor
 16" viewable

ONLY \$489⁹⁸
 #76514



ONLY \$1749
 #77048

High end performance at an entry-level price!

Apple® PowerBook® 1400cs/166

166MHz PowerPC™ 603e RISC processor

16MB RAM, expandable up to 64MB

1.3GB hard drive

12X CD-ROM drive

• 11.3" dual-scan color SVGA display

• Flip-up keyboard – easy internal access for upgrades

• 16-bit stereo input/output

State-of-the-art technology for an unbelievable price!

Apple® Power Macintosh® G3

- 233MHz PowerPC™ G3 processor
- 32MB RAM, expandable to 192MB
- 4.0GB hard drive
- 24X CD-ROM drive
- 66MHz system bus speed
- 512KB 117MHz backside cache
- 2MB Video SGRAM
- Video input/output
- Built-in 10Base-T Ethernet

ONLY \$1699
 #77039

BLAZING G3 PROCESSOR!

Monitor sold separately.



CALL US TOLL-FREE!
 or **FAX** your order to 425-430-3500
 Shop online at
www.maczone.com

SOURCE CODE
MW804

1-800-436-0606

Circle 71 on your reader service card

A NASDAQ® COMPANY Ticker Symbol: MZON

J&R COMPUTER WORLD



One of America's Largest
Authorized Apple Dealers



G3 Desktop Dependability!

Apple® Power Macintosh® G3/233 32MB/4GB/24xCD

- 233MHz PowerPC™ G3 •32MB RAM •4GB IDE hard drive •64-bit graphics •24x-speed CD-ROM drive
- Built-in 10Base-T ethernet •Monitor sold separately

\$1999⁹⁹ (APP M6141LL/A)



Apple Power Macintosh G3/266 32MB/4GB/24xCD/100MB Zip™ Drive

- 266MHz PowerPC™ G3 •32MB RAM •4GB IDE hard drive •24x-speed CD-ROM •100MB iomega Zip™ drive
- Built-in 10Base-T ethernet •Monitor sold separately

\$2399⁹⁹ (APP M6202LL/A)



Apple® Power Macintosh® G3/266 32MB/6GB/24xCD/100MB Zip™ Drive

- 266MHz PowerPC™ G3 •32MB RAM •6GB IDE hard drive •100MB iomega Zip™ drive •2MB VRAM •24x-speed CD-ROM •Monitor required

\$2999⁹⁹ (APP M6142LL/A)



Apple® Power Macintosh® G3/233 32MB/4GB/24x CD

- 233MHz PowerPC™ G3 processor •32MB RAM •4GB hard drive •24x-speed CD-ROM •Up to 56K fax modem •Monitor sold separately

\$2199⁹⁹ (APP M6431LL/A)



Apple® Power Macintosh® G3/266 128MB/4GB/24x CD

- 266MHz PowerPC™ G3 processor •128MB RAM •4GB hard drive •24x-speed CD-ROM •Monitor sold separately

\$4199⁹⁹ (APP M6459LL/A)

(APP M6459LL/A)



PowerPC and the PowerPC logo are trademarks of International Business Machines Corporation, used under license herefrom. Apple, the Apple logo, Macintosh, Power Macintosh, PowerBook, Apple SuperDrive & AppleDesign are registered trademarks of Apple Computer, Inc. Zip drive is a trademark of Iomega Corporation. ©1998 Apple Computer, Inc. All rights reserved. Apple, the Apple logo, LaserWriter, Macintosh, Power Macintosh, PowerBook, and QuarkXPress are registered trademarks of Apple Computer Inc. All other trademarks are the property of their respective owners. All Apple products are designed to be accessible to individuals with disabilities. For more information in the U.S. only, call 1-800-766-2333 or 100-1-800-633-6233.

Jaz Drive SPECIAL!



iomega® External Jaz™ Drive

- Factory refurbished with one-year warranty from manufacturer •An ideal solution for storing, archiving, and transporting data •Pack up to 1GB on each disk, there is no limit to the number of disks you can use •Portable •Can be used for Mac or PC •For SCSI interfaces •Includes one 1GB cartridge

\$199⁹⁹ (BER JAZEXTRB)

Additional 1GB Jaz Cartridge (formatted for Macintosh) (BER MAC1GIGCART) **\$79.99**

Printers



Hewlett-Packard DeskJet® 870Cse

- Color Inkjet Professional Series Printer
- 8-ppm black and 4-ppm color
- PC/Mac compatible
- RISC •HP RealLife Imaging

\$299⁹⁹ (HP C4565A)

Hewlett-Packard LaserJet 6MP (HP C3982A) **\$949.99**

Apple® LaserWriter® 12/640PS (APP M3977LL/A) **\$1599.99**

Hewlett-Packard LaserJet® 4MV (HP C3142A) **\$2699.99**

Monitors



Panasonic PanaSynch® 570

- 17" Flat Square Color Monitor
- 16" viewable image size •1280 x 1024 Ntsc •Up to 158Hz refresh rates •0.27mm dot pitch •AGRAS™ coating •FREE Macintosh adapter from Panasonic •100-240 volts

\$499⁹⁹ (PAN 570)

Panasonic PanaSynch P15 15" (14" VHS) (PAN P15) **\$299.99**

AppleVision® 750-AV 17" Display (16.1" VHS) (APP MS239LL/A) **\$899.99**

AppleVision® 850-AV 20" Display (19" VHS) (APP MS228LL/A) **\$1999.99**

J&R CORPORATE SALES BUSINESS LEASING:

No Money Down,
No Payments for 30 Days!

- 1) Allows flexibility to add or upgrade equipment at any time
- 2) Conserves your capital
- 3) Saves time, credit decisions are quick and easy
- 4) Covers entire packages— equipment, software, service contracts, and peripherals

*All lease payments are exclusive of applicable taxes. Minimum leasing payment is \$50 per month. All leases are subject to credit approval and require an administrative fee of \$49.95 to be billed on the first invoice. Leasing program administered by Dana Commercial Credit. Leases are Business Leases, 50 down, 36 month term with \$1.00 purchase option.



Call J&R Corporate Sales
1-800-221-3191 or
1-212-238-9080

(\$1,400 Minimum Lease Amount)

Software



Mindscape Microshaft Windows 98

\$16⁹⁹

- Civilization II by WizardWorks **\$42.99**
- Classic Rock Guitar #1 by UbiSoft **\$19.99**
- Duke Nukem 3D- Atomic Ed. by GT Value **\$42.99**
- Links LS by Access **\$42.99**
- Quake by WizardWorks **\$42.99**
- Simpsons Virtual Springfield by 20th Cent./Fox **\$24.99**



Intuit MacInTax 1997 Deluxe

\$34⁹⁹
after \$15 mail-in rebate

- Encarta 98 Encyclopedia Dlx. by Microsoft **\$69.99**
- Eudora Mail Pro (3.1.1) by Qualcomm **\$29.99**
- Norton Utilities (3.5) by Symantec **\$89.99**
- Organizer (2.0) by Claris **\$69.99**
- QuarkXPress (4.0) by Quark **\$749.99**
- Speed Doubler (8.0) by Connectix **\$54.99**

Digital Cameras



Sharp VE-LC1

- Digital Still Camera with 2.5" LCD Monitor
- 4MB flash memory •640 x 480 VGA resolution •Stores up to 120 images •Windows/Mac compatible
- AC adaptor, batteries, case & strap

\$299⁹⁹ (SHA VELCTU)

- Casio QV-200 (CAS QV200) **\$399.99**
- Olympus D-220L (OLM D220L) **\$499.99**
- Olympus D-500L (OLM D500L) **\$899.99**

SyQuest SyJet Drive



SyQuest® SyJet™

- 1.5-Gigabyte External Cartridge Hard Drive
- Removable disk cartridges hold up to 1.5GB of data •Small, lightweight and easily portable •Comes with one 1.5GB cartridge and cables for PC and Macintosh

\$299⁹⁹ (SYQ SYJET1SE-38)

Spare SyJet 1.5GB Cartridge (SYQ SYJET-005) **\$79.99**

SyQuest SyJet 1.5GB Cart 3-Pack (SYQ SYJET-006) **\$199.99**

(cartridges preformatted for Mac)

Microtek Scanners



Microtek ScanMaker E3+

- 30-Bit Single-Pass Color Scanner
- 300 x 600 dpi •8.5" x 13.5" scan area •SCSI interface •Comes with ColorIt, OmniPage LE, ScanWizard, Kai's Photo Soap, plus much more

\$149⁹⁹ (MTK SCANE3+MAC)

ScanMaker E6 Pro Mac (30-bit) (MTK SCANE6PRMAC) **\$559.99**

\$60 mfg. rebate (ends 3/31) \$499.99 Final Cost

ScanMaker 9600XL (36-bit) (MTK V9600XL-MAC) **\$1399.99**

Order Your FREE Catalogue Now!



- Global Village TelePort 56K x2 External Data/Fax Modem 56Kbps Downloads **\$159⁹⁹**



Philips OMNIWriter Writes CD-Rs, Reads CD-ROMs, Writes CD-RWs **\$499⁹⁹**

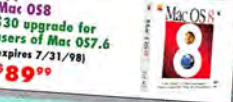

Apple Mac OS 8 \$30 upgrade for users of Mac OS 7.6 (expires 7/31/98) **\$89⁹⁹**

To Order Toll Free and Receive a Free Catalogue MAIL ORDERS: J&R Computer World

800-221-8180

24 Hours, 7 Days, Anywhere In The USA or FAX us at 1-800-232-4432

• 59-50 Queens Midtown Expressway • Maspeth, Queens NY 11378

CALL 1-800-221-8180 for shipping information. DO NOT SEND CASH.

Not responsible for typographical or pictorial errors. Some quantities may be limited. All merchandise brand-new, factory-fresh and 100% guaranteed!

Circle 282 on reader service card

CDW®

is more than just a great price...
We're great service too!

Power Mac G3

Monitor sold separately

NEW LOW PRICES!

- 233MHz or 266MHz PowerPC™ G3 processor
- 66MHz system bus speed
- 32MB RAM standard
- 4GB or 6GB IDE hard drive
- 24X Max CD-ROM drive
- Cometa Zip drive (on select models)

As low as! **\$1879.59** CDW 99851

Stylus Color 600

Price Drop!

- 1440 x 720 dpi photo quality color and laser quality black text on premium paper
- 720 x 720 dpi photo quality color and laser quality black text on plain paper
- Print speeds: up to 6 ppm black; up to 4 ppm color

\$249.00 CDW 80668

Computers

Apple® Power Macintosh® Series	
5500 225MHz PowerPC 32MB	
2GB 24X 10BT	1798.79
6500 250MHz PowerPC 32MB	
4GB 24X	1865.89
6500 275MHz PowerPC 32MB	
6GB 24X iomega Zip drive	2339.85
6500 275MHz PowerPC 48MB	
6GB 24X iomega Zip drive	2625.79
6500 300MHz PowerPC 64MB	
6GB 24X iomega Zip drive	2789.95
G3 233MHz PowerPC G3 4GB	
32MB 24X	1879.59
G3 266MHz PowerPC G3 4GB	
32MB 24X iomega Zip drive	2279.85
G3 266MHz PowerPC G3 6GB	
32MB 24X iomega Zip drive	2849.75
Apple® Macintosh® PowerBook® Series	
1400c 166MHz PowerPC 603e	
16MB 2GB 11.3" AM 8X	2796.56
1400cs 166MHz PowerPC 603e	
16MB 1.3GB 11.3" DS 12X	2189.00
2400c 180MHz PowerPC 603e	
16MB 1.3GB 10.4" AM	2389.55
3400c 200MHz PowerPC 603e	
16MB 2GB 12.1" active 12X CD	3579.88
3400c 240MHz PowerPC 603e	
16MB 3GB 12.1" AM 12X	4229.27
G3 250MHz PowerPC G3 32MB	
5GB 12.1" AM 20X	5489.77
AM = active-matrix display	
DS = dual-scan display	

UMAX	
SuperMac Series Desktops	
C500 240MHz PowerPC 603e	
24MB 3GB 24X	1295.00
C500e 240MHz PowerPC 603e	
24MB 3GB 24X 10BT	1395.00
J700 233MHz PowerPC 604e	
24MB 2GB 24X 10BT	1995.00
SuperMac Series Mini-towers	
C600LT 240MHz PowerPC 603e	
24MB 2GB 12X	1395.00
C600VP 240MHz PowerPC 603e	
32MB 3GB 24X 10BT	1495.00
C600X 280MHz PowerPC 603e	
32MB 4GB 12X 10BT	1995.00

Handheld Computers

eMate 300	789.67
MessagePad 2100	935.49

Monitors

MultipleScan 15AV 15" 0.28mm	389.38
MultipleScan 720 17" 0.28mm	628.74
AppleVision 750 17" 0.25mm	819.84
AppleVision 750AV 17" 0.25mm	919.70
AppleVision 850 20" 0.26mm	1699.82
AppleVision 850AV 20" 0.26mm	1829.59

Monitors

MAG	
DJ530 15" 0.28mm	267.44
DJ700 17" 0.26mm	516.69
DJ800 19" 0.26mm	789.39
DJ920 21" 0.28mm	1267.90
MAGNAVOX	
105S 15" 0.28mm	209.64
107S 17" 0.28mm	408.16
NEC	
A500 15" 0.28mm	267.44
E500 15" 0.25mm	335.71
A700 17" 0.25mm	517.82
E700 17" 0.25mm	564.41
P750 17" 0.25mm	785.91
E1100 21" 0.28mm	1219.66
P1150 21" 0.28mm	1349.21
SONY	
100ES 15" 0.25mm	339.30
200ES 17" 0.25mm	607.00
400PS 19" 0.27mm max.	1146.50
20SF2 20" 0.30mm	956.97
ViewSonic®	
G771 17" 0.27mm	449.13
G773 17" 0.26mm	479.98
GS771 17" 0.27mm	489.60
G790 19" 0.26mm	784.80
G800 20" 0.28mm	994.80
G810 21" 0.25mm	994.80
P775 17" 0.25mm	566.28
PT775 17" 0.25mm	667.76
P810 21" 0.25mm	1099.98
PT813 21" 0.28mm	1248.13
PB15 21" 0.25mm	1239.54

Video Boards

Nexus GA 8MB PCI	496.54
Xclaim TV external TV tuner	79.79
Xclaim 3D 4MB PCI	177.03
Xclaim 3D 8MB PCI	229.32
Xclaim VR 4MB PCI	248.02

Communications

Megahertz 33.6 Ethernet 10BT	
PC Card w/RU11	299.64
Courier I-modem	339.78
GLOBAL VILLAGE	
TelePort 56K x2 external	155.48
TelePort 56K K56flex external	149.33
TelePort 56K PLUS Mac OS 8	
K56flex external	174.98
TelePort 56K PLUS Mac OS 8	
x2 external	174.98
56K bps fax/modem PC Card	249.34
56K bps fax/modem/Ethernet PC Card	348.50
Robotics	
Sportster 56K x2 fax/modem external	179.13
Sportster 33.6 external	119.17

HP LJ 4000se

NEW!

- Resolution: up to 1200 dpi with HP ProRes
- Print speed: up to 17 ppm
- Includes HP LaserJet Publishing Internet Kit
- HP C3094A

\$1149.00 CDW 97680

Data Storage

Hi-Val SounTastic 16X CD Kit	
w/software external	219.29
Hi-Val SounTastic 24X CD Kit external	179.91
Hi-Val SounTastic 2X6 CD-Recording system external	389.59
iomega	
Zip drive 100MB external	139.95
ZipPlus 100MB external	199.95
100MB Zip disk 3-pack	49.95
Jaz drive 1GB external	399.95
Jaz drive 2GB internal	549.95
Jaz drive 2GB external	649.95
1GB Jaz disk 3-pack	299.95
LACIE	
2.1GB Quantum ST Ultra SCSI-3 internal	259.00
3.2GB Quantum ST Ultra SCSI-3 internal	299.00
4.3GB Quantum ST Ultra SCSI-3 internal	359.00
6.4GB Quantum ST Ultra SCSI-3 internal	469.00
9.1GB Quantum Ultra SCSI-3 internal	629.00
2GB Apple drive Ultra SCSI-3 external	389.00
3GB Apple drive Ultra SCSI-3 external	429.00
4GB Apple drive Ultra SCSI-3 external	499.00
Quantum	
2.1GB Fireball SE Ultra SCSI-3	219.16
3.2GB Fireball SE Ultra SCSI-3	265.62
4.3GB Fireball SE Ultra SCSI-3	299.02
6.4GB Fireball SE Ultra SCSI-3	389.65
8.4GB Fireball SE Ultra SCSI-3	507.77
SyQuest®	
SyJet 1.5GB SCSI external	299.99
SyJet 1.5GB cartridge	79.99

Scanners

AGFA	
SnapScan flatbed scanner	379.63
SnapScan 310 flatbed scanner	199.83
SnapScan 600 Art Line flatbed scanner	537.80
EPSON®	
Action Scanning System II	279.88
Expression 636 Executive scanner	799.00
Expression 636 Artist scanner	999.00
Expression 636 Professional scanner	1399.00
Expression 836XL scanner	2499.00
HP HEWLETT® PACKARD	
HP ScanJet 6100Cse flatbed scanner	799.00
MICROTEK	
ScanMaker E3 360 scanner	145.80
ScanMaker V600 scanner	239.63
ScanMaker E6 Standard scanner	285.15
ScanMaker E6 Professional scanner	524.91
ScanMaker 6400XL scanner	926.01
Nikon	
LS-20 Super CoolScan II	909.09
Super CoolScan film scanner	1745.63
Polaroid	
SprintScan 35LE film scanner	796.56
SprintScan 35ES film scanner	1469.51
SprintScan 35+ film scanner	1808.96

BUY WITH CONFIDENCE

CDW® IS A NASDAQ TRADED COMPANY
TICKER SYMBOL CDWC D & B rated 5A1 Duns 10-762-7932

Credit card charges are not submitted until time of shipment. For your protection, we ship only to your credit card's verified billing address. Freight is calculated as the carrier's actual freight charge plus insurance and packaging material. The cost of insurance is 0.35% (0.0035) of the order total. Packaging materials will not exceed \$4.00 for single package shipments or \$6.00 for multi-package shipments. Before returning any product, you must obtain an RMA number. Non-defective returns are subject to a restocking fee. Software, chips and other electronic components are not returnable. Allow 10 business days for shipping when paying by personal check. All pricing subject to change. For all prices, products and offers, CDW reserves the right to make adjustments due to changing market conditions, product discontinuation, manufacturer price changes, errors in advertisements or other extenuating circumstances. All trademarks and registered trademarks are the sole property of their respective owners.

Call today!

800-509-4239

19" color monitor

ViewSonic® Model G790

- 19" high contrast screen, 18" viewable image size
- 0.26mm dot pitch
- Maximum resolution: 1600 x 1280 at 76Hz; 1280 x 1024 at 88Hz
- 3-year parts, labor and CRT warranty

Price Drop!

\$784.80 CDW 98512

Scanners

UMAX	
Astra 610S flatbed scanner	140.87
Astra 1200S flatbed scanner w/full Adobe PhotoDeluxe	239.33
Astra 1200S flatbed scanner w/full Adobe Photoshop	439.34
PowerLook II	1319.32
VISIONER	
PaperPort vx scanner	146.57

Printers

EPSON®	
Stylus Color 600	249.00
Stylus Color 800	349.00
Stylus Color 1520	799.00
Stylus Color 3000	1999.00
Stylus Photo	399.00
HEWLETT® PACKARD	
HP DeskJet 340 portable ink jet printer	256.11
HP DeskJet 870Cxi printer	299.57
HP DeskJet 1600CM printer	1969.33
HP LaserJet GMP printer	879.85
HP LaserJet 4000se printer	1149.00
HP LaserJet 551 MX printer	3118.72
LACIE	
LaserWriter 8500	2399.29

Digital Imaging

AGFA	
ePhoto 307 digital camera	329.67
ePhoto 1280 digital camera	829.97
EPSON®	
PhotoPC 600XGA digital camera	699.00
Kodak	
DC50 digital camera w/Zoom lens	499.00
DC120 digital camera w/Zoom lens	799.00
DC210 digital camera	899.00
Nikon	
Coolpix 300 digital camera	674.06
Panasonic	
KXL-600A digital camera	398.79
Polaroid	
PDC 2000/40 digital camera	1445.40
PDC 2000/60 digital camera	1779.89

UPS Systems

APC	
PowerChute software for Novell NetWare	59.20
Back-UPS Office	104.76
Back-UPS 200	79.95
Back-UPS 400	129.07
Back-UPS 600	219.95
Smart-UPS 450NET	327.55
Smart-UPS 700NET	406.11
Smart-UPS 1000NET	479.95
Smart-UPS 1400NET	699.98
SurgeArrest P7 Home	9.17
SurgeArrest Personal	19.82
SurgeArrest Pro	28.74
SurgeArrest Network	31.66

CDW® DIRECTORY

PC sales	800-726-4239
Mac sales	800-509-4239
Corporate sales	800-280-4239
Corporate software sales	800-294-4239
Government and Education sales	800-615-4239
Networking sales	800-861-4239

CDW® TELEPHONE HOURS

Sales	
Monday-Friday 7 a.m.-9 p.m. CT	
Saturday 9 a.m.-5 p.m. CT	
Tech support & returns 800-383-4239	
Monday-Friday 7 a.m.-9 p.m. CT	
Saturday 9 a.m.-5 p.m. CT	

COMPUTER DISCOUNT WAREHOUSE

The right price. The right advice.

800-509-4239

MEGAHAUS BEST BUY AWARD WINNER!



• UNBEATABLE DEALS •

• IOMEGA JAZZ DRIVE

Full retail package in Iomega case. 1GB External w/1 disk [JAZX] \$374
1GB Media any qty [JAZCIGIMAC] \$82

• SYQUEST SYJET DRIVE

Drive in our case. Ask about mail-in offer. External w/1 disk [SYJET1.SJEX] \$345
Media any qty [SJ1.5C] \$84

• ADAPTEC CONTROLLERS

Wide Single [A2940MUW] \$269
Wide Dual [A3940MUW] \$529
FireWire+Wide [AHA8945] \$639

• Quantum 9 GB Sale

Ultra Wide SCSI, 5 Year Warr.
Int. \$689 [XP39100WCM]
Ext. \$749 [XP39100WCMX]

• WIDE SCSI BUNDLE

Name brand 7200rpm Wide SCSI drive, and an Adaptec Wide SCSI controller. 4GB internal [4GIGCOMBOMI] \$539
4GB external [4GIGCOMBOMX] \$649
9GB internal [9GIGCOMBOMI] \$929
9GB external [9GIGCOMBOMX] \$1039

• QUANTUM IDE DRIVES

3.2GB [FB33200A] \$185
4.3GB [FB34300A] \$209
6.4GB [FB36400A] \$275
8.4GB [FB38400A] \$365

• HITACHI 2.5" IDE DRIVES

2.1GB [DK225A21] \$219
3.2GB [DK226A32] \$319
4.0GB [DK227A41] \$459

• CD RECORDERS •

Smart Storage Solutions CDR Drives Include:

- ✓ Toast Mastering Software
- ✓ 5 FREE disks
- ✓ Toll Free support



Duo Master systems include: 1 FREE cartridge!

CDR + Jaz or Syjet Combo perfect for CD recording!

CD Recordable Includes 5 Free Recordable Disks!	External	Duo
2x6 Sony, caddy load, 1MB buffer	\$375	\$689
4x8 Matsushita, tray load	\$445	\$759
4x12 Teac, tray load, 1MB buffer	\$525	\$839
4x12 Plextor, caddy/tray load, 1MB buffer	\$579	\$895
CD Rewritable Includes 5 Free ReWritable Disks!		
2x6 Ricoh, tray load, 1MB buffer	\$505	\$819
2x6 Ricoh, caddy load, 2MB buffer	\$525	\$839
2x4x6 Yamaha, tray load, 1MB buffer	\$615	\$929

• CD RECORDABLE MEDIA •

	Alone	w/CDR	Budget Pack	Budget w/CDR
5 Pack [CDR74-5]	\$21	\$19	\$19	\$17
20 Pack [CDR74-20]	\$42	\$39	\$37	\$34
50 Pack [CDR74-50]	\$93	\$89	\$79	\$74
100 Pack [CDR74-100]	\$175	\$169	\$147	\$141

• CD REWRITABLE MEDIA •

	Alone	w/CDR	Budget Pack	Budget w/CDR
5 Pack [CDR74W-5]	\$99	\$94	\$80	\$76
20 Pack [CDR74W-20]	\$360	\$355	\$299	\$289
50 Pack [CDR74W-50]	\$879	\$869	\$699	\$689

• CD PRINTABLE MEDIA • (Color CD Printer only \$1039)

	Alone	w/CDR	Budget Pack	Budget w/CDR
5 Pack [CDR74P-5]	\$28	\$25	\$24	\$21
20 Pack [CDR74P-20]	\$69	\$66	\$59	\$56
50 Pack [CDR74P-50]	\$149	\$145	\$129	\$119
100 Pack [CDR74P-100]	\$279	\$269	\$219	\$209

• CD ROM DRIVES •

	External
NEC 16X 100ms 256K Tray	\$159 [CDR1610XM]
Nakamichi 16X 130ms 5 Disk Changer	\$279 [MJS16XM]
Plextor 20X 95ms 512K Tray	\$249 [PX20TSM]
NEC 24X 85ms 128K Tray	\$179 [CDR1810XM]
Pioneer 24X 90ms 6 Disk Changer	\$419 [DRM6324XM]
Teac 32X 85ms 512K Tray	\$179 [CDS32SXM]
Toshiba 32X 85ms 128K Tray	\$189 [XME201BXM]
Plextor 32X 85ms 512K Tray	\$289 [PX32TSM]

• SCSI TAPE BACKUP •

These tape drives include backup software for Mac, Win95, WinNT, and 1 FREE TAPE!

Seagate Travan 4GB, 30MB/min	\$439 [STT2800XM]	4-8GB, 60MB/min	\$539 [STT2800CXM]
Sony 4mm 4-8GB, 44MB/min	\$759 [SDT5000XM]	12-24GB, 144MB/min	\$1099 [SDT9000XM]
4-8GB, 90MB/min	\$829 [SDT7000XM]	32-64GB, 90MB/min	\$1949 [TSL7000XM]
Seagate 4mm 2-4GB, 66MB/min	\$679 [STD2400XM]	12-24GB, 120MB/min	\$1109 [STD22400XM]
4-8GB, 60MB/min	\$849 [STD2800XM]	48-96GB, 120MB/min	\$2419 [STL49600XM]
Hewlett Packard 4mm 2GB, 11MB/min	\$679 [C1534XM]	12-24GB, 120MB/min	\$1199 [C1554XM]
2-4GB, 42MB/min	\$709 [C1536XM]	72-144GB, 120MB/min	\$2699 [C5648XM]
4-8GB, 60MB/min	\$919 [C1599XM]		
Exabyte 8mm 7-14GB, 60MB/min	\$729 [EXB8700LTXM]	20-40GB, 360MB/min	\$3549 [EXB8900XM]
7-14GB, 120MB/min	\$1549 [ELIANTXM]	70-140GB, 60MB/min	\$4249 [EXB10HM]
Quantum DLT 15-30GB, 150MB/min	\$2569 [DLT2000XTXM]	100-200GB, 180MB/min	\$5809 [DLT4500M]
20-40GB, 180MB/min	\$2889 [DLT4000XM]	105-210GB, 150MB/min	\$6539 [DLT2700XTM]
35-70GB, 600MB/min	\$6449 [DLT7000XM]	140-180GB, 150MB/min	\$7869 [DLT4700M]
75-150GB, 150MB/min	\$4719 [DLT2500XTM]		
Seagate AIT 25-50GB, 360MB/min	\$2999 [STA150000XM]	100-200GB, 360MB/min	\$Call [STL42000M]

We sell all brands of hard drives, tape drives, optical drives, CD duplicators, CD recorders, CD mastering software, CD towers, CD ROM, RAID adapters and software, controllers, enclosures, mounting brackets, PCMCIA adapters and drives, laptop hard drives, & much more. See our web site or call with your requirements.

We custom configure to your needs:

RAID

A/V

Call us

Super cooling drive fan. \$30 Alone or added to an external hard drive.

• SCSI HARD DRIVES •

Quantum

2111MB	9.5ms	5400rpm	512K	FB32100S	3yr	\$199	\$259
2275MB	8ms	7200rpm	512K	VK32275S	5yr	\$249	\$299
3228MB	9.5ms	5400rpm	512K	FB33200S	3yr	\$235	\$289
4310MB	9.5ms	5400rpm	512K	FB34300S	3yr	\$279	\$329
4550MB	8ms	7200rpm	512K	VK34550S	5yr	\$349	\$399
4550MB	8ms	7200rpm	512K	XP34550S	5yr	\$469	\$519
6448MB	9.5ms	5400rpm	512K	FB36400S	3yr	\$359	\$409
8455MB	9.5ms	5400rpm	512K	FB38400S	3yr	\$459	\$509
9100MB	8ms	7200rpm	512K	XP39100S	5yr	\$749	\$799
ULTRA WIDE SCSI (Adaptec PCI Wide controller only \$195 with drive!)							
2275MB	8ms	7200rpm	512K	VK32275W	5yr	\$249	\$339
2275MB	8ms	7200rpm	512K	XP32275W	5yr	\$199	\$289
4550MB	8ms	7200rpm	512K	VK34550W	5yr	\$349	\$439
4550MB	8ms	7200rpm	512K	XP34550W	5yr	\$479	\$569
9100MB	8ms	7200rpm	512K	XP39100W	5yr	\$749	\$839

Seagate

2150MB	11ms	5400rpm	128K	ST52160N	3yr	\$199	\$259
2160MB	8ms	7200rpm	1024K	ST32272N	5yr	\$329	\$379
4550MB	9.1ms	7200rpm	512K	ST34555N	3yr	\$325	\$375
4550MB	8ms	7200rpm	512K	ST34572N	5yr	\$469	\$519
4550MB	7.5ms	10,000rpm	512K	ST34501N	5yr	\$599	\$649
9100MB	8ms	7200rpm	512K	ST19171N	5yr	\$749	\$799
9100MB	8ms	10,000rpm	512K	ST19101N	5yr	\$949	\$999
23200MB	13ms	5400rpm	512K	ST423451N	5yr	\$1669	\$1759
WIDE SCSI (Adaptec PCI Wide controller only \$195 with drive!)							
2160MB	8ms	7200rpm	512K	ST32272W	5yr	\$369	\$459
4550MB	8ms	7200rpm	512K	ST34572W	5yr	\$499	\$589
4550MB	7.5ms	10,000rpm	512K	ST34501W	5yr	\$599	\$689
9100MB	8ms	7200rpm	1024K	ST19171W	5yr	\$759	\$849
9100MB	8ms	10,000rpm	512K	ST19101W	5yr	\$969	\$1059
23200MB	13ms	5400rpm	512K	ST423451W	5yr	\$1689	\$1839

IBM

4550MB	8.5ms	5400rpm	512K	IBM34330N	5yr	\$295	\$345
9100MB	7.5ms	7200rpm	512K	IBM39130N	5yr	\$729	\$779
9100MB	6.5ms	7200rpm	1MB	IDGHS09Z	5yr	\$959	\$1009
18200MB	7.5ms	7200rpm	1MB	IDGHS18Z	5yr	\$1759	\$1809
ULTRA WIDE SCSI (Adaptec PCI Wide controller only \$195 with drive!)							
4550MB	8.5ms	5400rpm	512K	IBM34330W	5yr	\$299	\$389
9100MB	7.5ms	7200rpm	512K	IBM39130W	5yr	\$749	\$849
9100MB	6.5ms	7200rpm	1MB	IDGHS09U	5yr	\$959	\$1059
9100MB	6.5ms	10020rpm	1MB	IDVGS9U	5yr	\$1019	\$1119
18200MB	7.5ms	7200rpm	1MB	IDGHS18U	5yr	\$1759	\$1859

WESTERN DIGITAL

2100MB	8ms	7200rpm	512K	WDE2170N	5yr	\$339	\$389
4300MB	8ms	7200rpm	512K	WDE4360N	5yr	\$489	\$539
9100MB	8ms	7200rpm	512K	WDE9100N	5yr	\$739	\$789
ULTRA WIDE SCSI (Adaptec PCI Wide controller only \$195 with drive!)							
2100MB	8ms	7200rpm	512K	WDE2170N	5yr	\$349	\$439
4300MB	8ms	7200rpm	512K	WDE4360N	5yr	\$499	\$589
9100MB	8ms	7200rpm	512K	WDE9100N	5yr	\$749	\$839

Since 1987 The Drive Authority

MEGAHAUS



2201 Pine Drive, Dickinson, Texas 77539

(281)534-3919 FAX (281)534-6580

http://www.megahaus.com

1-800-786-1184

Sales lines open: M-F 8-8 Sat 9-3 CST

Prices & specifications subject to change without notice. Shipping charges are non-refundable. Returns must be in original condition and original packaging. Defective items may not be returnable. Non-refundable on software and special orders (items not listed in ad). All refunds subject to 15% restocking fee. All trademarks are registered trademarks of their respective companies. Personal checks held for clearance. We reserve the right to refuse any sale for any reason. Bundle price good only if sold at price. All warranties listed are manufacturer's warranty only. ©1997 MegaHaus Inc.

APS HIGH-PERFORMANCE ULTRA SCSI DRIVES

Model	Description	EL	Int.	SR 2000	Pro
APS Q 2000	Quantum Fireball ST, 2079MB, 5.4K	\$199 ⁹⁵	\$219 ⁹⁵	\$289 ⁹⁵	\$319 ⁹⁵
APS Q 3000	Quantum Fireball ST, 3118MB, 5.4K	229 ⁹⁵	249 ⁹⁵	319 ⁹⁵	349 ⁹⁵
APS Q 4000	Quantum Fireball ST, 4110MB, 5.4K	279 ⁹⁵	299 ⁹⁵	369 ⁹⁵	399 ⁹⁵
APS Q 6400	Quantum Fireball ST, 6236MB, 5.4K	359 ⁹⁵	379 ⁹⁵	449 ⁹⁵	479 ⁹⁵
APS Q 8000	Quantum Fireball ST, 8191MB, 5.4K	479 ⁹⁵	499 ⁹⁵	569 ⁹⁵	599 ⁹⁵
APS Q 4300	Quantum Atlas II, 4341MB, 7200 rpm		479 ⁹⁵	549 ⁹⁵	579 ⁹⁵
APS Q 9000	Quantum Atlas II, 8682MB, 7200 rpm		749 ⁹⁵	819 ⁹⁵	849 ⁹⁵
APS ST 2000	Seagate Barracuda, 2157MB, 7200 rpm		379 ⁹⁵	449 ⁹⁵	479 ⁹⁵
APS ST 4300	Seagate Barracuda, 4340MB, 7200 rpm		549 ⁹⁵	619 ⁹⁵	649 ⁹⁵
APS ST 4500	Seagate Cheatah, 4348MB, 10000 rpm		649 ⁹⁵	N/A	749 ⁹⁵
APS ST 9000	Seagate Barracuda, 8683MB, 7200 rpm		779 ⁹⁵	849 ⁹⁵	879 ⁹⁵
APS ST 9100	Seagate Cheatah, 8681MB, 10000 rpm		999 ⁹⁵	N/A	1,099 ⁹⁵
APS WD 2000	Western Digital Enterprise, 7200 rpm		379 ⁹⁵	449 ⁹⁵	479 ⁹⁵
APS WD 4300	Western Digital Enterprise, 7200 rpm		579 ⁹⁵	649 ⁹⁵	679 ⁹⁵

APS HIGH-PERFORMANCE ULTRA SCSI DRIVES

Model	Description	Full Height
APS ST 23000	Seagate Elite 23, 22.1GB, 5400 rpm	\$1,799 ⁹⁵
APS ST 23000 W	Seagate Elite 23, 22.1GB, 5400 rpm	1,899 ⁹⁵

APS ULTRA WIDE SCSI DRIVES

Model	Description	Int.	SR 2000	Pro
APS Q 4300 W	Quantum Atlas II, 4341MB, 7200 rpm	\$499 ⁹⁵	\$569 ⁹⁵	\$599 ⁹⁵
APS Q 4500 W	Quantum Viking, 4345MB, 7200 rpm	579 ⁹⁵	649 ⁹⁵	679 ⁹⁵
APS Q 9000 W	Quantum Atlas II, 8682MB, 7200 rpm	779 ⁹⁵	849 ⁹⁵	879 ⁹⁵
APS ST 2000 W	Seagate Barracuda, 2157MB, 7200 rpm	399 ⁹⁵	469 ⁹⁵	499 ⁹⁵
APS ST 4300 W	Seagate Barracuda, 4340MB, 7200 rpm	579 ⁹⁵	649 ⁹⁵	679 ⁹⁵
APS ST 4500 W	Seagate Cheatah, 4348MB, 10,000 rpm	699 ⁹⁵	N/A	799 ⁹⁵
APS ST 9000 W	Seagate Barracuda, 8683MB, 7200 rpm	799 ⁹⁵	869 ⁹⁵	899 ⁹⁵
APS ST 9100 W	Seagate Cheatah, 8681MB, 10,000 rpm	1,049 ⁹⁵	N/A	1,149 ⁹⁵
APS WD 2000 W	Western Digital Enterprise, 7200 rpm	429 ⁹⁵	499 ⁹⁵	529 ⁹⁵
APS WD 4300 W	Western Digital Enterprise, 7200 rpm	599 ⁹⁵	669 ⁹⁵	699 ⁹⁵

APS IDE DRIVES

Model	Description	Internal
APS Q 3000	Quantum Fireball ST, 3118MB, 5400 rpm	\$199 ⁹⁵
APS Q 4000	Quantum Fireball ST, 4136MB, 5400 rpm	249 ⁹⁵
APS Q 6400	Quantum Fireball ST, 6236MB, 5400 rpm	329 ⁹⁵

APS POWERBOOK STORAGE

Model	Description	Internal
APS T 2000	Toshiba MK2103MAV, 2067MB, 4200 rpm IDE	\$299 ⁹⁵

APS REMOVABLE DRIVES

Model	Description	SR 1000	SR 2000	Pro
APS SQ 5200	SyQuest 5200, 190MB	N/A	\$389 ⁹⁵	N/A
APS Jaz	(with 1 cartridge) 1GB	349 ⁹⁵	349 ⁹⁵	399 ⁹⁵
APS Jaz II	(with 1 cartridge) 2GB	Call	Call	Call

APS MO DRIVES

Model	Description	SR 1000	SR 2000	Pro
APS 640 MO	Fujitsu M2513A2#N	N/A	419 ⁹⁵	449 ⁹⁵
APS 2.6GB MO	Sony SMD-F544, 2.4GB	N/A	1,669 ⁹⁵	1,699 ⁹⁵

APS CD-ROM DRIVES

Model	Description	External
APS CD32	32X CD-ROM in Slimline Case	\$159 ⁹⁵
APS CD Changer	Nakamichi 5 Disc/16X CD-ROM, Pro Case only	299 ⁹⁵
APS CD-R Plus	2X record/6X read CD-R (Sony)	379 ⁹⁵
APS CD-R Pro	4X record/6X read CD-R in Pro Enclosure	529 ⁹⁵
APS CD-R Pro	4X record/6X read CD-R in Full Height Enclosure	729 ⁹⁵
APS CD-RW	2X record/6X read CD-RW in Pro Enclosure	529 ⁹⁵
APS CD-RW Pro	4X record/6X read/2X rewrite CD-RW, Pro Enclosure	599 ⁹⁵
APS Jaz/CD-R System	2X record/6X read CD-R	749 ⁹⁵
APS 2GB/CD-RW	Sys.Q 2000 Hard Drive & 2X record/6X read CD-RW	799 ⁹⁵

*Available in an SR 2000 Enclosure for an additional \$50.00

APS TAPE BACKUP SYSTEMS

Model	Description	Internal	External
APS HyperQIC®	Travan 4 Corner QIC 3095, 8GB	\$349 ⁹⁵	\$399 ⁹⁵
APS HyperDAT®	DDS-2DC, 8GB	549 ⁹⁵	599 ⁹⁵
APS HyperDAT®	ProDDS-2DC, 8GB	849 ⁹⁵	899 ⁹⁵
APS HyperDAT® III	DDS-3DC, 24GB	1,149 ⁹⁵	1,199 ⁹⁵
APS Mini Library	4mm DDS-2 AutoLoader, 84GB	N/A	2,399 ⁹⁵
APS DLT30	DLT 3000, 30GB	N/A	2,499 ⁹⁵
APS DLT40	DLT 4000, 40GB	N/A	2,999 ⁹⁵
APS DLT70	DLT 7000, 70GB	N/A	6,999 ⁹⁵
APS AIT*	8mm W/DC, 50GB	N/A	3,199 ⁹⁵
APS DL1	4MM DDS-2 AutoLoader, 136GB	N/A	4,999 ⁹⁵

*See Adapter PowerDomain 2940 Ultra Wide SCSI Host Adapter offer to gain maximum throughput. Call for information about Windows 95 and Windows NT versions of these great drive products

Prices in Red are Hot Deals! Order online @ <http://www.apstech.com>

Mac Backup as low as \$349⁹⁵!

APS HyperQIC®

The best value ever in a high performance tape backup system ever for Mac! The APS HyperQIC uses reliable, industry-standard Travan 4 tape cartridges to backup up to 8GB* of data on one tape.

HyperQIC Starter Kit

(Includes three TR-4 cartridges, one drive cleaner kit) part # 106625 \$119.95

*Assumes 2:1 data compression

Upgrading to System 8.1?

According to Apple, before you can take advantage of the improved hard disk management of Mac OS 8.1, you must back up the entire contents of your drive. The APS HyperQIC in the portable, stackable SR 2000 enclosure is the most economical way to do that.

\$599⁹⁵
APS Pro Enclosure

Save Big! on the APS HyperDAT®

■ Up to 8GB on a single 120m DAT tape**

■ Includes Mac/PC/NT backup software

Now just \$599.95 in the APS Pro enclosure!

**Assumes 2:1 data compression

120M DAT Starter Kit (includes five DAT tapes, one DAT head cleaner, one LabelOnce DAT starter kit, one Micro-Data storage cube) part # 100590 \$99.95

APS JAZ II Call for Special Pricing

■ Huge 2GB capacity

■ Reads and writes 1GB Jaz disks

■ Includes cartridge



APS ECONOMY LINE DRIVES

■ Perfect replacement drives!

■ No expensive extras that you don't need



APS Q 2000 EL 2079MB formatted, 5400rpm (Quantum mechanism) \$199⁹⁵

APS Q 3000 EL 3118MB formatted, 5400rpm (Quantum mechanism) 229⁹⁵

APS Q 4000 EL 4136MB formatted, 5400rpm (Quantum mechanism) 279⁹⁵

APS Q 6400 EL 6236MB formatted, 5400rpm (Quantum mechanism) 359⁹⁵

The APS Economy Line of drives is intended as replacements for your current hard disk. They do not include brackets, cables or screws. Please keep your invoice for warranty purposes.

APS Q 4300 W \$529⁹⁵

■ Productivity boost for creatives

■ Faster transfers with Ultra Wide SCSI

Shown in APS Pro Enclosure

PCI ULTRA WIDE SCSI HOST ADAPTER ADAPTEC POWERDOMAIN™ 2940UW FOR MAC \$199⁹⁵

With the purchase of any APS Ultra Wide SCSI drive



Call 800-285-0638 Today

Mac OS is a registered trademark of Apple Computer, Inc. APS and APS Technologies are registered trademarks of Alliance Peripherals Systems, Inc. Other brand or product names are registered trademarks or trademarks of their respective holders.

• 30-day money back satisfaction on all APS brand drives and accessories. Your risk is the cost of shipping.

• Monitor and 3rd party products carry warranties from their respective manufacturers.

• *EIS cables sold separately.

• APS warranty is a pass-through of the manufacturer's warranty which will be serviced by APS for one year. APS warrants APS branded enclosures, brackets and power supplies for one year from the date of purchase and will, at its discretion, repair or replace products found to be defective according to the specific terms of the warranty accompanying the product.

• Refund orders subject to 25% restocking fee.

• International customers must pay for all shipping charges.

• Listed capacities are formatted.

• Actual data compression and tape capacity vary greatly depending on the type of data stored, other system parameters and environment.

• Prices and specifications are subject to change without notice.

• You must install system software appropriate to your machine before using our hard drives.

• Not responsible for typographical errors.

• Your APS Drive will may contain one or more components that were in prior use, but which have been inspected and repaired or rebuilt as necessary. These components, if any are covered by the same warranty provisions, exclusions and limitations to the same extent, and on the same terms as otherwise "new" components.

© 1998 Alliance Peripherals Systems, Inc. All Rights Reserved.

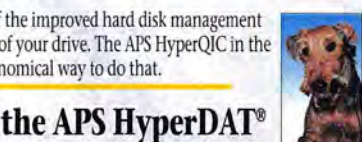

"Hi, I'm Jennifer. Call me!"

PRODUCT INDEX

Category	Page No.	Category	Page No.
Business Operations	142-143	Peripheral Products	146-147
Bar Code		Magnetic Media	
Inventory Management		Cd Rom	
Print Utility		Services	170-171
Video/Display		Color Printing	
Communications/		Data Recovery	
Networking	146	Digital Production	
Cross Platform		Repair	
Education/		Systems & Peripherals	146-167
Entertainment	143-145	Account Managers	800.825.4237
Discount Software		Spencer Frasher.....	212.503.5864
Graphics	143	sfrasher@zd.com	
Translation		Michelle LeWinter...212.503.5122	
Clip Art		mlewinte@zd.com	
Memory & Upgrades	167-170	Kristin Newman.....212.503.5862	
Memory Upgrade		knewman @zd.com	
Digital Advertising Coordinator:		Jessica Turko.....212.503.5140	
Brian Mullin	415.267.1735	jturko@zd.com	
brian_mullin@macworld.com		Sales Manager:	
		Monifa Kelly.....212.503.5155	
		mkelly@zd.com	

printChef = POWER PRINTING!

See why thousands of people and your competition are turning to printChef to get the print job done!

Use our automatic booklet maker, or design your own and attach as your application adds to the new mini-paper size!

Toner control at the page or object level!

Paper thickness control for paper booklets

Head-to-toe & reversed printing

Automatic mistakes - simply choose a layout

Paper control that you wouldn't believe possible

"This (simple) extension has more printing power than packages priced at \$5,000"

Rick Bantelman, DANKA

To boost the printing power of any application, call **(800) 648-6840** or try our demo at **www.mindgate.com**

printChef

Introductory price **\$45** (until 3/31/98) ...so that everyone can make their printer sizzle right now!

60-day money-back guarantee

List Price: Base unit \$95
Net: \$15-\$25/unit
(931) 937-6800
Worldwide: (931) 937-6801
Fax Orders: (931) 937-6801

Install in English, French, German, and Spanish

printChef is a print extension that sits between any application & any printer driver... it uses **Print Recipes** that you design to control any application's output...

System 7+ required! For 6800 & any PowerMac. Works with ANY printer & ANY application. printChef's miracles require only 32K of memory. QuickDraw GX is NOT required!

MindGate, printChef & their logos are registered trademarks. PrintChef is a trademark. It's not printing magic... it's printing science!™ is a trademark of MindGate Technologies.

MindGate® Technologies, Inc.
164 Oliver Smith Road
Flinville, TN 37335-6335

or thru
MACWORLD
800-255-6227

CIRCLE 430 ON READER SERVICE CARD

BAR CODE SOLUTIONS

• LABELING SOFTWARE

• BAR CODE FONTS

• SCANNERS/LASERS

• GRAPHIC UTILITIES

FREE EXPERT CONSULTATION

FREE LIFETIME TECHNICAL SUPPORT

MONEY-BACK GUARANTEE

UPC/EAN, CODE 39, ITF, POSTNET, 2-D

International Bar Code Expertise
300,000 Customers Worldwide

Bear Rock TECHNOLOGIES

800-232-7625

916-672-0244 FAX: 916-672-1103

"This is the best product of it's kind, and it's reasonably priced too."
- MacUser on Trintiker For Macintosh

Visit Our Website At:
www.bearrock.com

CIRCLE 431 ON READER SERVICE CARD

SOFTWARE SALE

1-800-258-0297

MICROSOFT Office 4.21	\$225
MICROSOFT Word 5.0/6.0.1	\$80/135
MS Excel 5/Powerpoint 4 (each)	\$155
MICROSOFT Front Page	\$ 77
ADOBE ILLUSTRATOR 7	\$230
ADOBE PHOTOSHOP 4.01	\$370
ADOBE PAGEMAKER 6.5	\$290
ADOBE PREMIER 4.2	\$370
AfterEffects/Production Bundle	\$350/1250
Streamline 4/Dimension 3	\$125
ADOBE Type Manager Deluxe	\$ 45
ADOBE AROBAT.3.01	\$ 80
ADOBE PAGEMILL 2.0	\$ 70
CLARIS FILEMAKER PRO	\$150
MetaCreations Detailer	\$130
MetaCreations Expression	\$130
MetaCreations Painter 5.0	\$235
MetaCreations Kai's PowerTools	\$ 90
MetaCreations Bryce 3D	\$135
DANEBA CANVAS 5.0	\$225
MACROMEDIA Freehand 7.0	\$210
Freehand Graphic Studio 7.0	\$290
Sound Edit 16/Edit 11	\$270

call for other item not listed

T.I.N.
FAX 1-800-260-3988
Call 9AM to 6PM PST. PRICE SUBJECT TO CHANGE WITHOUT NOTICE/LIMITED STOCK ALL TRADEMARKS ARE PROPERTY OF THEIR RESPECTIVE OWNERS.

POINT OF SALE INVENTORY CONTROL

- Retail
- Rentals
- Service
- Manufacturing
- Multi Location

Bar Code/Magnetic Stripe Readers
Receipt Printers • Cash Drawers
Credit Card Auth. & Deposit Software
Download Demos and Interactive Catalog at our Web Site: <http://www.postdirect.com>
call, fax, or e-mail for a FREE CATALOG
(800) 622-7670 sales@postdirect.com
(618) 985-8237 TEL • (618) 985-3014 FAX
Dealer Inquiries Welcome
30 day MBG

CIRCLE 432 ON READER SERVICE CARD

Newton® Joins the Mac-Barcode® Family!

One Stop Shopping with Friendly Support from the Experts

Simple Fast Accurate

Newton® Walk-About™
Mac-Barcode Pro Label Software
SmartLaser/SmartScanner/SmartPen
Call for Literature/Free Demo Disk

The Mac-Barcode Co.
800-733-7592
<http://www.mac-barcode.com>

Bar Code Pro[®] v3.5 with Veribar[™]



Create perfect PostScript (EPS) bar code graphics for Quark, PageMaker, Illus., etc.

Bar Code Pro[®] features:

- ✓ All popular bar code symbologies
 - ✓ Any printer resolution! No fonts required.
 - ✓ No prior bar code experience necessary.
 - ✓ No more bar code film masters.
 - ✓ Veribar built-in verification (optional).
 - ✓ Pays for itself in a single use.
- "Takes sixty seconds to install, five minutes to master!"— MacWorld

CALL FOR FREE DEMO

SNX www.snx.com Tel: (800) 619-0299 Fax: (718) 768-3997
(formerly SYNEX)

CIRCLE 433 ON READER SERVICE CARD

CADMOVER v.5

What good is a built in translator if it doesn't work?

You've worked hard and now it's time to use those files in another program. You try to import them & all you get is garbage. Not with CADMOVER. For over ten years we've been helping people beat their deadlines, no re-drawing, no touch-ups.

File formats: DWG, DXF, EPSF, PICT, CGM, IGES, HPGL, STL, MinicAD, DDES2, etc... Internal Features: scaling, 2D/3D views, font mapping and more. With 17 decimal place accuracy redrawing is a thing of the past.

KANDU
software corporation

voice 800-579-2244 • fax 540-839-3489 • www.kandusoftware.com

Bar Code Headquarters



- Portable Batch Readers
- Cordless Interactive RF Bar Code Readers
- ADB Bar Code Readers
- Wand, Laser, CCD, Magstripe or Slot Badge
- PostScript Bar Code Fonts

- 30 Day \$ Back Guarantee
- Free Shipping in USA
- Toll Free Tech Support

WORTHINGTON
DATA SOLUTIONS

1-800-345-4220
Or Call 408-458-9938
Website: www.barcodehq.com



LifeART Professional Medical Clip Art



www.lifeart.com **1-800-543-3278**

Attn: Students-Teachers-Schools

ArchiCAD 5.0	\$ 99	Japan.LangK	\$125
Authorware 4	739	Kai's PowerT.	79
CodaFinale97	245	KPT Bryce 3D	115
CorelDRAW 6	129	MiniCAD 7	315
Debab.Toolbox	279	MS FrontPage	74
Director 6	339	MS Office 4.21	198
Dreamweaver	169	MS Word 6.01	99
Electric Image	1329	Norton Utilities	65
Eye Candy 3.0	74	Painter 5.0	205
FileMaker Pro	135	Studio Pro 2.1	545
Final Draft 4.1	145		
Flash 2.0	145		
Form-Z 2.92	Call		

1-888-416-4555
Call for Catalog!

*We accept Purchase Orders from schools.
*Call for Adobe, Microsoft & QuarkXpress!!
Aca Software Express Inc.
898 Anderson Ave #3
Cliffside Park, NJ 07010
Tel:201-941-5429 Fax:201-941-5154

STUDENTS, TEACHERS, SCHOOLS SAVE UP TO 80%



315.00
Diehl Graphsoft
MiniCAD 7

Azimuth 2.5...199
Blueprint 5...149

We'll Beat ANY Advertised Price!!

Adobe, Microsoft, Lotus, & Borland products available.

4th Dimension 6.0	249	FileMaker Pro 4.0	139	NetObjects Fusion 2.0	149
Authorware 4.0	739	Final Draft 4.1	139	Nisus Writer 5.0.1	85
Canvas 5.0.3	179	Finale 97	249	OmniPage Pro 8.0	329
Claris HomePage 3.0	59	Fractal 3D Suite 2.0	299	PageTools 2.0	69
Claris Works 5.0	89	Fractal Art Dabbler 2.0	39	Phototools 2.0	89
Cliff Notes Studyware	19	Fractal Detailer 1.0	129	Quickeys 3.5.2	85
CodeWarrior Pro 2.0	119	Fractal Expression	99	QX-Tools 2.0	69
Conflict Catcher 4.0	59	Fractal Painter 5.0	219	Ray Dream Studio 5.0	129
CorelDRAW Ste 6.0	165	Fractal Poser 2.0	79	Ray Dream 3D	69
CyberStudio 2.0.1	175	FreeHand 8.0	149	Softwindows 95 5.0	199
Debabelizer Toolbox	219	Infini-D 4.0	289	Strata Media Paint 1.x	179
Director 6 w/E-Doc	339	Kai's Photo Soap	39	Strata Studio Pro 2.1	549
Director MMS 6	675	Kai's Power Tools 3.0	85	Strata VideoShop	79
Director MMS Upgd	399	KPT Bryce 3D 3.0	119	Total Xaos Bundle	119
Dreamweaver	149	KPT Vector Effects	99	Umax Astra 600S	239
Electric Image Broadcast	1339	LightWave 3D 5.5	799	Wacom ArtPad 4x5	129
Encore 4.2	279	Logomotion 2.1	65	Wacom ArtZ II 6x8	285
EndNote Plus 2.x Stu.	99	Mac OS 8.1	85	Wacom ArtZ II 12x12	399
Epson Photo Printer	389	Mathematica 3.0 Stu	149	Web Graphics Suite	69
Eye Candy	75	Mathview	99	WordPerfect 3.5.1	39

WebSite www.ElectronicImage.com • Fax (510) 798-2464 • FREE Catalog

TOLL FREE 1-888-EDU-SOFT

CIRCLE 434 ON READER SERVICE CARD

CALL US ABOUT MACWORLD SPECIALS!

IF WE DON'T SELL IT, IT'S NOT WORTH LOOKING AT.



PANELIGHT IS YOUR ONE STOP SHOP FOR ALL LEADING BRANDS SALES, RENTALS, & LEASES • MONEY BACK GUARANTEE.

TRUSTWORTHY
TECHNICAL
GUIDANCE
AND SUPPORT

QUICK
DELIVERY

MONEY-BACK
GUARANTEE

- Epson
- CTX
- nView
- In Focus

CALL
PANELIGHT FOR
OUR
FREE CATALOG:
1-800-726-3599.

MON.-FRI., 6:30AM-5:30PM P.S.T.
24-HR. FAX: 415-986-3817
OR E-MAIL: SALES@PANELIGHT.COM

HTTP://WWW.PANELIGHT.COM

PANELIGHT DISPLAY SYSTEMS, INC.,
P.O. BOX 190940,
SAN FRANCISCO, CA 94119.
OR CALL 415-772-5800.

TREMENDOUS
SELECTION OF
ALL LEADING
PROJECTORS

SALES, LEASES
OR RENTALS

DISCOUNT
PRICES

- Toshiba
- Polaroid
- Proxima
- Panasonic



CALL THE EXPERTS
AT PANELIGHT
DISPLAY SYSTEMS, INC.

CIRCLE 435 ON READER SERVICE CARD

Student - Teacher - School Discounts!

18 Perfect People 1.0.....	\$199
Adam Comprehensive Student ED.....	\$99
FastTrack Schedule 5.0.....	\$139
Private File.....	\$35
Spring Cleaning 2.0.....	\$35
StuffIt Deluxe 4.5.....	\$55
Eye Candy 3.0 After Effects.....	\$349
SuperCard 3.0.....	\$129
Andromeda Series 3 OR 4.....	\$75
Andromeda Shadow Filter.....	\$75
Terra Forma Regional 1,2 OR 3.....	\$129
DesignWorkshop 1.7.....	\$199
FileGuard 3.0.8.....	\$119
Asound 3.0.....	\$99
Page/Edges 3.0.....	\$135
Photo/Graphic Edges V1,2 OR 3.....	\$135
WebVise Totality.....	\$99
AutoCAD R12.....	\$199
Form Z 3.0.....	CALL
Elastic Reality 3.0.....	\$1149
BBEdit 4.5.....	\$79
Final Draft 4.1.....	\$149
M.Y.O.B 7.0.....	\$49
Bitstream Collection.....	\$129
TypeShop Pro.....	\$129
Kidpix Studio.....	\$35
Sculpt 3D 4.2.....	\$219
Conflict Catcher 4.0.....	\$59
Spell Catcher 1.5.....	\$49
Crickit Graph III 1.5.3.....	\$79
OmniPage Pro 7.0.....	\$329
Metro 3.5.....	\$129
Cumulus Desktop 3.0.....	\$95
Quickeys 3.5.2.....	\$85
MicroGrade.....	\$69
Anubis RAID.....	\$79
Backup Mastery.....	\$59
Chromatica.....	\$79
HomePage 2.0.....	\$69
HyperCard 2.3.5.....	\$89
Japanese Language Kit 1.2.....	\$129
QuickTime VR Authoring Studio.....	\$299
Remote Access Server 3.0.....	\$109
ClarisWorks 5.0 Office.....	\$89
Classic PIO Partners.....	CALL
Cliff Notes College Bound Bundle.....	\$35
Vivace Practice Studio.....	\$199
Speed Doubler 8.....	\$55
Virtual PC.....	\$149
WordPerfect 3.5.1.....	\$69
CorelDRAW Suite 6.....	\$169
Life Forms 2.1.....	\$199
ChemOffice Pro 4.0 Student.....	\$299
Retrospect 4.0.....	\$109
WildRiverSSK 1.1.....	\$85
Canvas 5.0.3.....	\$179
DenebaCAD 1.0.....	\$269
MathType 3.5.....	\$99
Aurorix 2.....	\$159
CineLook 1.0 Broadcast.....	\$429
Digital Textures Bundle.....	\$199
Illuminaire Studio.....	\$1299
Lion King Animated StoryBook.....	\$36
Logic 3.0.....	\$249
Epson Expression 636Executive.....	\$769
Epson Stylus Color 1520 InkJet Print.....	\$789
Epson Stylus Color 3000 InkJet Print.....	\$1929
DeBabelizer Tool 1.6.5.....	\$229
IntelliHance 3.0.....	\$69
Mask Pro 1.0.....	\$199
Portfolio 3.0.....	\$69
QX Effects 3.0.....	\$89
Hard Disk Toolkit 2.01.....	\$109
Killer Transitions.....	\$189
TelePort 56x2 Modem.....	\$179
Power Trans German 2.0.....	\$95
ArchiCad 5.0 Student.....	\$129
Grolier 1998 Encyclopedia Deluxe.....	\$69
Teacher's Tool Kit.....	\$69
CADtools 1.0.....	\$99
Squizz! 3.0.....	\$69
Textissimo 2.0.....	\$69
PowerPrint 3.0.2.....	\$89
StyleScript 3.6.....	\$89
Inspiration 5.0.....	\$79

WE WILL BEAT ANY ADVERTISED PRICE * LATEST VERSION & FULL PACKAGES

\$599

Photo Design
Illustration Page Layout

Market-Leading Page Layout software
Market-Leading Illustration software
Market-Leading Photo Design software

From the world's leading desktop publishing software manufacturer... 3 market leading DTP Tools

DeskTop Publishing Bundle

\$269

Boris FX 3.0

Video Effects for Premiere

\$139

FileMaker Pro 4.0

#1 Relational Database

NEW!

\$249

Coda Finale 97

Music Notation Software

\$159

Berserk 1.3

\$49

Virex 5.8

AntiVirus Program

\$619

Jaz 2GB External Drive

Expand your Hard Drive Without Limits

\$179

CyberStudio 2.0.1

Website Building Software

NEW!

\$149

Creator2

Desktop Publishing & Layout

NEW!

\$119

CodeWarrior Pro 2

C/C++ Programming

\$85

Mac OS 8

System Software for the Macintosh

\$329

Infini-D 4.0

3D Modeling & Animation

\$89

PhotoTools 2.0

Photoshop Plug-In

Call for FREE Catalog!
(800) 831-2295

Includes Complete Price List & Free Product Info.

*SAME DAY SHIPPING ON MOST ITEMS.
**ADOBE, SYMANTEC & MICROSOFT PRODUCTS AVAILABLE TO QUALIFIED STUDENTS, TEACHERS & SCHOOLS.
***SCHOOL PURCHASE ORDERS WELCOME.
****NO SURCHARGE ON CREDIT CARDS.
*****IBM & MAC PRODUCTS AVAILABLE.

Priority Code: 3086

Visit our **NEW** Web Site!
<http://www.swsonline.com>

The SOFTWARE Source
1-800-831-2295

1750 Brielle Ave, Unit A-2
Ocean, NJ 07712
PHONE (732) 695-2100
FAX (732) 695-9371
E-MAIL: SFTSWS@AOL.COM

CIRCLE 436 ON READER SERVICE CARD

Student - Teacher - School Discounts!

WE WILL BEAT ANY ADVERTISED PRICE * LATEST VERSION & FULL PACKAGES

\$479



Artist's Dream Bundle
Wacom Art Z II 6x8 & Painter 5.0

\$379



Epson Stylus 800
Color Inkjet
High performance
1440x720 dpi Printing

\$119



Bryce 3D
3D Terrain And Animation

\$1349

Your Career In 3D Animation Begins Here!

ElectricImage™ BROADCAST
Hi-Speed Rendering

\$349



Director 6 E-Doc
Director 6 with Online Documentation

\$79



Eye Candy 3.0.1
Special Effects for Photoshop

\$199



Freehand Graphics Studio
Includes FreeHand 7, Fontographer, Extreme 3d, and xRES

\$149



NetObjects Fusion 2
Smart Way to Build Web Sites

\$339



MiniCad 7.0.1
2D/3D Cad Software

\$129



Total Xaos
Includes Paint Alchemy 2.0, Terrazzo 2.0 & Typecaster

\$79



MagicMask
Masking Tool for Photoshop

\$79



DOUBLER PACK
Includes Ram Doubler 2 & Speed Doubler 8

CALL



LightWave 3D 5.5
Modeling & Animation

Call for FREE Catalog!
(800) 831-2295
Includes Complete Price List & Free Product Info.

**SAME DAY SHIPPING ON MOST ITEMS.
**ADOBE, SPANTEC & MICROSOFT PRODUCTS AVAILABLE TO QUALIFIED STUDENTS, TEACHERS & SCHOOLS.
**SCHOOL PURCHASE ORDERS WELCOME.
**NO SURCHARGE ON CREDIT CARDS.
**IBM & MAC PRODUCTS AVAILABLE.

Visit our **NEW** Web Site!!
<http://www.swsonline.com>

MovieWorks Interactive 4.0	\$79
ZipPlus 100 Ext SCSI/Parallel	\$199
ClearVideo 1.2	\$229
Screen Caffeine Pro 2.2	\$75
JudsonRosebush Wildside Bundle 5	\$149
Topdown Flowcharter 4.5	\$155
Orbit Trackball	\$69
LightningDraw Gx 1.0.3	\$99
Live Picture 2.6.1	\$199
PhotoVista	\$65
Trackman Marble	\$85
MTrapolis 1.1	\$549
Mac Academy Tutorial Videos	\$35
Authorware 4.0	\$749
Director 6 Multimedia Studio	\$679
Flash 2.0	\$149
SoundEdit 16+ Deck II	\$249
Mosaic 1.5	\$249
Mathematica 3.0 Student	\$149
3D Suite 2.0	\$299
Art Dabbler 2.1	\$39
Kai's Photo Soap 1.0	\$39
Kai's Power Goo 1.0	\$39
Kai's Power Tools 3.0.2	\$85
Logomotion 2.1	\$39
Painter 5.0	\$219
Poser 2.0	\$79
RayDream Studio 5.0	\$129
Color It! 3.2	\$39
Enhance 4.0	\$129
Nils' Actions	\$49
PC MACLAN 6.1	\$129
Netscape Communicator Pro 4.0.1	\$49
EndNote Plus 2.2 w/EndLink	\$165
Nisus Writer 5.1	\$85
Now Up To Date 3.6.5	\$79
Studio VisionPro 3.5.4	\$499
ObjectDancer 1.1	\$199
MacInDos Plus 2.0	\$45
Pantone Personal Color Calibrator	\$35
Encore 4.1.1	\$249
SPIN Panorama	\$79
MeshPaint 3D 1.6	\$69
Storyboard Artist 1.5	\$329
LabVIEW Student	\$99
Matlab 5.0 Student	\$99
SPSS 6.1 Student	\$99
Eudora Pro 3.1.1	\$35
Coda 2.0	\$249
HyperStudio 3.1	\$119
RubberBall Faces	\$199
PosterWorks 4.0	\$249
Jmp 3.2	\$329
Dramatica Pro 2.0	\$199
PageMaker Fraemz PS Deluxe	\$129
HotMetal Pro 3.0	\$85
DeltaGraph 4.0	\$89
SigmaPlot 5.0	\$199
ListSTAR 1.1	\$329
WebSTAR 2.1	\$329
Cubase VST 3.5	\$199
StudioPro 2.1	\$549
Vision 3D 5.0	\$29
Hollywood FX 3.0.5	\$359
KaleidaGraph 3.0	\$119
Media Cleaner Pro 2.0	\$249
Myrmidon 2.0	\$35
DAVE 1.0	\$65
WebPainter 2.0	\$69
Sportster 56K Ext	\$209
Flo' 2.6.3	\$69
MetaFlo' 2.0.3	\$319
3D Dizzy 1.0	\$69
3D HotText 1.0	\$99
3D Words 1.0	\$69
Presenter 3D 3.6	\$995
Walkthrough Pro 2.6	\$229
Test Strip 1.1	\$89
VivoActive Producer 1.5	\$55
Art Z II 12x12 Tablet	\$399
Art Z II 6x8 Tablet	\$285
Paint Alchemy 2.0	\$79
EPS Invigorator 1.5	\$249
Vector Lathe 1.0	\$119
Heads & Hair Collection	\$219



1-800-831-2295

1750 Brielle Ave, Unit A-2
Ocean, NJ 07712
PHONE (732) 695-2100
FAX (732) 695-9371
E-MAIL: SFTSWS@AOL.COM

Priority Code: 3086

Networking Macs and PCs Leave You Stranded?

Let PC MACLAN Save You . . . Time, Money and Resources

Now whether you're a small business, home office or workgroup you can operate as efficiently as a corporate network with PC MACLAN — the leading solution for sharing printers, files, drives and more between Mac OS and Windows PCs, including remote and internet access.

- Add PCs to a Mac-based Network
- Print to AppleTalk or PostScript Printers from a PC
- Share Drives, Email and Applications Cross-platform

PC MACLAN is available for Windows NT, Windows 95 and Windows 3.x . . . and at our prices, PC MACLAN won't drown your networking budget!

www.miramarsys.com
 1-800-862-2526



"For peer-to-peer networking . . . PC MACLAN 6.0 is the only choice."
 — Macworld - Nov. '96



CIRCLE 438 ON READER SERVICE CARD

Macsense Palm Router

NEW

For Mac & PC

One Palm Router+
 One Modem +
 One ISP account +
 One Phone line =
**Web access for
 up to 6 Users**



- The most economical way to get everyone on the Internet.
- Ideal for the classroom, small office or home.
- Serves as a 4 port 10BASE Ethernet LAN Hub.
- Up to 36 users on the local area network.

Other products: Fast Ethernet PCI adapters, Hubs, LAN switches and more....

CALL-1-800-642-8860 to find a dealer near you

Distributor, Reseller & Rep Welcome



Just Macsense Technology Inc.

Tel: 1-800-642-8860 Fax: 408-744-1060
 1290 Reamwood Ave. #B Sunnyvale, CA 94089
<http://www.macsensetech.com>

800-944-4237

MEDIA SUPPLY

Quality Products, Fast Service & Great Prices!

CD-R Media 2x/4x/6x
\$1.58 **CD-RW Drive**
\$548

Sony, Mitsui, and TDK.
 Every CD-R guaranteed!

Internal Yamaha Drive/Includes
 Adaptec CDCreator & 1 CD-RW

CD-R Copiers
 Starting at:
\$2498



CD-R Copying Services

Call us for great pricing on copying and printing your CD-R copy job. We make the smallest job look professional!

Sure our prices are great, but our service is even better!

www.mediasupply.com



610-458-9100 • Fax: 610-458-9464

CIRCLE 439 ON READER SERVICE CARD

More Serial Ports for Your Mac!

Better than a Switch or Juggler

- Provides simultaneous use of ports
- More stable than port sharing products
- Data rates up to 230 Kbps
- PCI serial cards available in 2 or 4 port versions
- For use with Comm Toolbox savvy software

SX-2 Only \$229



Your Satisfaction is Guaranteed

- 30 day money back guarantee
- 5 year warranty
- SX-2 just \$229 SX-4 only \$329
- Free FedEx 2 day shipping

Call 800-986-9146 to Order

Order from FedEx: 7am-9pm M-F (CST)
 Authorization #: i35 • Source code: 25J



(510) 222-0131 www.keyspan.com

© Copyright 1997, KEYSPAN is a trademark of ImoSys Inc. Other brand names are trademarks or registered trademarks of their respective holders.

CD-ROM PRODUCTION

1000 Retail-Ready Stamped CDs

Includes two color discs, four color glossy insert & tray cards, jewel case, and poly wrap. Complete turnkey — just send a CD-R and art files! Call for details.



CATALOGIC®

Your CD-ROM Production Source™
<http://www.catalogic.com>

935 Sierra Vista Avenue • Mountain View, CA 94043
 Telephone: 650-961-4649 Fax: 650-962-5333

- Easy to use labeling kits
- CD-R silk screening service
- Short run CD-R duplication
- 4.1Gb/hour standalone duper

CD-R media as low as \$1.49

800-255-4020



COMPUTER REVELATIONS

NEW & USED BOUGHT & SOLD
 Quadra 650s \$199.00

All G3s in stock!

Model	Price
7300/180	\$1599
7300/200	CALL
8600/200/300	CALL
9600/200/300/350	CALL
7200/7600/8500/9500	CALL
PRINTERS	
LWRITER 12/640	CALL
LWRITER 4/600	\$899
HP 6MP	CALL
HP 1600 C/PS	CALL
HP 4MV	\$2699
STYLEWRITER 1500/2500	CALL
POWERBOOK	
3400	CALL
1400	\$2299
1400C/117	CALL
1400C/133	CALL
UMAX / SUPERMAC	
S90L	CALL
S900D	CALL
SCANNERS	
VISTA/S66 SOHO	\$279
POWER LOOK II	\$1829
EXPRESSION 636	\$1389
AFGA SNAPSCAN	\$329
AFGA ARCUS II	\$1589
MONITORS	
APPLE 1705	\$695
CPD200SX	\$689
PRECISION. 21"SR	\$3299
CPD 1005X	\$379

ALL APPLE PARTS & ACCESSORIES IN STOCK

Leasing / Rentals / Supplies
 Service available in NYC area

1 800 275-9924
 in NY 516 737-0800
 FAX 516 737-0923

331E DANTE COURT HOLBROOK NY 11741

CIRCLE 440 ON READER SERVICE CARD

800-345-1234

DATA

www.datamicro.com

Sales: (310)-398-3300

Micro Computer Inc.

Fax: (310)-391-2488

3847 Grandview Blvd.
Los Angeles, CA 90066

Dealers & International Sales Welcome

e-mail: datamicro@earthlink.com

PowerMacs

6100/66	8/500/CD	\$699
6100/DOS	16/500/CD	\$899
4400/200	16/1GB/CD	\$1085
6500/225	32/3GB/CD	\$1449
6500/250	32/4GB/CD	\$1739
6500/275	Creative Studio	\$2149
6500/275	32/4GB/CD/Zip	\$2249
7200/120	16/1GB/CD	\$1149
7300/180	16/2GB/CD	\$1359
7300/200	32/2GB/CD	\$1549
7600/132	16/1GB/CD	\$1449
8500 & 9500 Series		CALL
8600/250	32/4GB/CD/Zip	\$2189
8600/300	32/4GB/CD	\$2489
9600/233	32/4GB/CD	\$2689
9600/300	64/4GB/CD	\$2989
9600/350	64/4GB/CD/Zip	CALL
G3/233	32/4GB/CD	\$1869
G3/266	32/4GB/CD/Zip	\$2199
G3/266	32/6GB/CD/Zip/AV	\$2779



PowerBooks

1400cs/133	16/1GB/CD	\$1849
1400c/133	16/1GB/CD	CALL
1400c/166	16/2GB/CD	\$2249
2300c	8/750	\$999
2300c	20/1GB/Modem	\$1399
2400c/180	16/1.3GB	\$2789
3400c/180	16/1GB/CD	\$2689
3400c/200	16/2GB/CD	\$2569
3400c/240	16/3GB/CD	\$3489
G3/250	32/5GB/CD	\$5299

Call for Software & Accessories not listed

UMAX SuperMac

500/600/700 Series		CALL
C600LT/240	24/2GB/CD/M	\$1349
J700/233	24/2GB/CD/M	\$1849
S900L/200	32/2GB/CD	\$2295
S900i/250	64/4GB/CD/Zip	\$3299

Performas

6116	8/700/CD	\$695
6116/DOS	16/700/CD	\$895
5200	8/500/CD/15"	\$795
6200	8/1GB/CD	\$649
6360	16/1GB/CD	\$895
6400/180	16/1GB/CD	\$969
6400/200	32/2.4GB/CD	\$1095

Printers

Apple LaserWriter 16/600	\$1489
LaserWriter 12/660	\$3495
LaserWriter 360	\$995
Style Writers	Lowest Price.
HP HEWLETT PACKARD LJ. 5SIMX	\$3389
LaserJet 4000	\$1495

Scanners

Agfa Arcus II	\$1475
Agfa Studio Star LE	\$689
UMAX PowerLook II	\$1249
EPSON Stylus 3000	\$1649

Monitors

Apple MultiScan 14"	\$229
MultiScan 15"	\$299
1705 (17")	\$599
MultiScan 20"	\$1475
radius 15" Grayscale	\$199
Pivot 15" Grayscale	\$295
20" Grayscale	\$695
17" Color	\$645
IntelliColor 20"	\$1099
Precision 21" Color	\$1495

ATI LPT LaserMaster CMSP
Microtek DayStar Products
in stock. Call for Best Price.

DIGITAL

Media 100qx	\$2195
Bravada 1000	\$629
Targa 1000PCI	\$1789
Targa 2000PCI	\$2698
IX Micro Twin Turbo SMB	\$595
Kodak DC 25	\$459
Kodak DC 50	\$859
Apex 4.6 Optical Drive	\$1685
Raid Array Hard Disks	CALL

We Specialize in Business Leasing

Prices are subject to change without notice!

Government, Universities & Corporations P.O.s are accepted

CIRCLE 441 ON READER SERVICE CARD

AMC ADVANCED MULTIMEDIA CONCEPTS

Call for our FREE Catalog!

888.558.3189

www.mwm.amc-direct.com

PLASMON DW260

The Plasmon DW260 Direct Overwrite Optical Drive is the fastest optical drive available for high performance applications. The DW260 provides full backwards media compatibility for the same cost as conventional MO drives.

Buy NOW and receive a 2-disk pack of 5.25, 2.3GB or 2.6GB rewritable media FREE!

*Offer good only with purchase of Plasmon DW260 drive

SAVE \$150!

MITSUI GOLD CD-R MEDIA



FREE CD-R Media!
Request your FREE Mitsui Gold CD-R online!

www.amc-direct.com/freecd

Mitsui Gold CD-R Media is simply the best in the industry and the only media to come with a lifetime warranty. You can't buy better media at a lower price anywhere!

Mitsui-Gold CD-R 10-pack	\$19.99
Mitsui-Gold CD-R 100pc. Case	\$179.99



CUSTOM SILKSCREENING

AMC's Custom CD Silk screening Service will launch your Image into the next Century!

Customize your Recordable CD's! AMC can provide your company with custom silk screened recordable CD's and CD printing options, as we have for hundreds of companies throughout the world!

Call AMC today for a complete design kit and information packet.



CD PRINTERS

AMC 720dpi Color CD Printer	\$849.
Fargo Color CD Printer	\$1,179.

CD RECORDERS

4x8 Internal Recorder	\$399.
4x8 External Recorder	\$489.

CD DUPLICATORS

CD-4004 Duplicator	starting at: \$2,599.
CD-2601 Duplicator	starting at: \$4,995.

Call for other configurations & options



P.O. Box 3456 • Redmond, WA 98073-3456 • Fax: 425.861.8391 • www.mwm.amc-direct.com

Ad Code MW0498

CIRCLE 442 ON READER SERVICE CARD

1800-533-9005

E-MAIL US AT: COMPAMER@aol.com
 (310) 446-1771 10435 Santa Monica Blvd
 FAX Bids: Santa Monica Blvd
 (310) 475-7744 LA, CA 90025
 We are open on Saturday!

COMPU AMERICA

"The Computer Specialist"

Check out our WEB!!!

UPDATED DAILY!!!
 Online Ordering
 Stock/Availability
 Color Photos
 Complete Specs

Shipping Estimates
 International Sales
 Credit/COD/Leasing
 No Wait! No hold!
 Completely Accurate!

[HTTP://WWW.COMPU-AMERICA.COM](http://www.compu-america.com)

Government, University, and Fortune 1000 P.O.'s are welcome! International Orders Please call (310) 446-1771

CALL OUR LEASING DEPARTMENT TODAY!

PowerBook 3400C/240

SPECIAL! 240MHz 603e
 16MRAM/3G/12XCD
 ACTIVE/ETHERNET
\$3099

PowerBook 3400C/200

SPECIAL! 200MHz 603e
 16/2GIG/12XCD
 ACTIVE/ETHERNET
\$2699

PowerBook 1400C/166

SPECIAL! 166MHz 603e
 16/2G/8XCD
\$1999

LaserWriter 12/640PS

SPECIAL! 30MHZ/8M RAM
 600DPI/12PPM
\$989

PowerMac 4400/200

SPECIAL! 200MHz 603e Desktop
 32MRAM/2G/CD
 256K CACHE, KEYBOARD
\$1299

PowerMac 8600/300

SPECIAL! 300MHz 604e Mini
 32/4GIG/24XCD
 2MB VRAM, KEYBOARD
\$2099

PowerBook 1400CS/166

SPECIAL! 166MHZ 603E
 16/2G/8XCD
\$1699

Power Mac G3/266MHZ

SPECIAL! G3/266MHZ
 32/6G/CD/ZIP
\$2599

NEW G3 POWERMACS!

G3/266MHZ 32/6G/24CD/ZIP 2599
 G3/266MHZ 32/4G/24CD/ZIP 2049
 G3/233MHZ 32/4G/24XCD 1699

NEW POWERMACS!

9600/350 64/4G/24X 3199
 9600/300 64/4G/24X 2699
 9600/200MP32/4GIG/CD 2499
 9600/233 32/4GIG/CD 2299
 9600/200 32/4GIG/CD 1999
 9600/200 0/0/CD 1399
 8600/300 32/4G/24X 2099
 8600/250 32/4G/24X 1899
 7300/PEN 32/2GIG/CD 1599
 7300/200 32/4GIG/CD 1499
 7300/180 16/2GIG/CD 1399
 6500/300 32/4GIG/CD 1899
 6500/275 64/4G/CD/ZIP 1799
 6500/250 32/4G/CD 1599
 6500/225 32/3G/CD 1399
 4400/200 16/2G/CD/KEY 999*
 4400/200 32/2G/CD/PEN 1299
 8500/150 16/2G/8XCD CALL
 7200/120 16/1G/CD 999*

Apple Printers

SW 2200 299
 SW 2500 229
 SW 4100 239
 SW 4500 339
 SW 6500 CALL
 Apple LW 8500 2399
 Apple LW 12/640/PS 999
 Apple LW 16/600PS 1279/999*
 Apple LW 12/660PSC 3499

APPLE Monitors

Apple 15" COMPATIBLE 199
 Apple MS 15AV 319
 Apple 1705 17" 469
 Apple 750 699
 Apple 750 AV 879
 Apple Multiscan 850 20" 1399
 Apple Multiscan 850AV 1799

SONY

Sony 100ES/100GS 329/359
 Sony 200ES/200GS 589/639
 Sony 200PS 17" 789
 SONY 400PS 19" 1099
 Sony 300SF 20" 1089
 SONY 200E 1649
 SONY 500PS 21" 1599

NEW G3 POWERBOOKS

G3/250MZ 32/5G/20CD/ETH 4299
 G3/250MZ 32/5G/20CD/MD 4499

POWERBOOKS

3400C/240 16/3G/12XCD/M 3299
 3400C/240 16/3G/12XCD 3099
 3400C/200 16/2G/12XCD/M 2899
 3400C/200 16/2G/12XCD 2699
 3400C/180 16/1.2G/12XCD 2799
 3400C/180 16/1.3G 2699
 2400C/180 16/1.3G 1999
 1400C/166 16/2G/CD 1999
 1400CS/166 16/2G/CD 1699
 1400C/133 16/1G/CD 1799
 1400CS/133 16/1G/CD 1599
 5300C/100 8/500 1195*
 5300CS/100 8/750 1099*
 DUO 2300C 8/750/14.4 999*
 DUO DOCK 429

PERFORMAS

6400/200V 16/2.4G/CD CALL
 6400/200 16/2.4GIG/CD CALL
 6400/180 16/1GIG/CD CALL
 6360/160 16/1.2G/8XCD CALL

WorkGroup Servers

7350/180 48/4G/CD/SHA CALL
 7350/180 48/4G/CD/INT CALL
 7350/180 48/4G/CD CALL
 9650/233 64/4G/CD/SHA CALL
 9650/233 64/4G/CD/INT CALL
 9650/233 64/4G/CD/DAT CALL

SOFTWARE SPECIALS

ADOBE PHOTOSHOP 329
 ADOBE PREMIER 349
 ADOBE ILLUSTRATOR 249
 ADOBE Pagemaker 329
 MACROMEDIA FREEHAND 249
 MICROSOFT ACCESS 199
 MICROSOFT WORD 179
 MICROSOFT EXCEL 179
 MICROSOFT POWERPOINT 179
 MICROSOFT OFFICE 249

GLOBAL VILLAGE COMMUNICATION

Global Village Plat 56k 149
 Global Village Gold II PCM 14.4 49
 Global Village Gold III 14.4EXT 49
 Global Village 56.6 PCMCIA 249
 Global Village 56.6 ETH/PCM 349

UMAX

VISTA Astra 610-LE 149
 VISTA Astra 1200-LE 249
 VISTA Astra 1200-PRO 449
 POWERLOOK III CALL
 POWERLOOK 3000 CALL
 MIRAGE IISE W/TRANS CALL



DIMAGE V 549
 DIMAGE SCAN 649
 QUICKSCAN 35 CALL



SNAPSCAN 310 199
 SNAPSCAN 600 389
 SNAPSCAN 600 ART LINE 529
 STUDIO STAR 799
 ARCUS II 1499
 EPHOTO 1208 CALL



ARTZ II 4 X 5 139
 ARTZ II 6 X 8 289
 ARTZ II 12 X 12 389
 ARTZ II 12 X 18 669

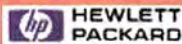

5SIMX 3399
 4000TN 1549
 4000N 1479
 51V/5M 1299/1399
 5MP 549*
 6MP 849
 4MV 2399



PRESSVIEW 21SR 2999
 PRESSVIEW 17SR 1699
 PRECISION VIEW 21" 1699
 Thunder Power 30/1600 599
 Thunder Power 30/1920 849
 Thunder 3D 1600 x1200 1699
 VIDEO VISION STUDIO 2.0 CALL

Processor Upgrades

APPLE POWERMAC 132MHZ 99
 APPLE POWERMAC 150 MHZ 149
 APPLE POWERMAC 200MHZ 249
 APPLE POWERMAC 233MHZ 399



PHASER 140 949
 PHASER 300X 4999
 PHASER 350 COLOR LASER 2999
 PHASER 380 7899
 PHASER 450 6099
 PHASER 480X 14495
 PHASER 550 COLOR LASER 3999
 PHASER 600WIDE FORMAT 11999



VIEWSONIC 15GA 329
 VIEWSONIC 17GA 499
 VIEWSONIC G771 17" 479
 VIEWSONIC G773 17" 499
 VIEWSONIC G775 599
 VIEWSONIC G790 799
 VIEWSONIC G800 899
 VIEWSONIC G810 979
 VIEWSONIC 29GA 2099
 VIEWSONIC P775 579
 VIEWSONIC P777 649
 VIEWSONIC P810 1079
 VIEWSONIC P815 1249
 VIEWSONIC P813 1199
 VIEWSONIC OPTIQUEST V775 499
 VIEWSONIC OPTIQUEST Q100 899
 VIEWSONIC WVPAn VPA138 2199
 VIEWSONIC WVPAn VPA150 2499



ULTIMATE REZ 8MB 529
 PRO REZ 4MB 279
 MAC ROCKET 4MB 239
 TWIN TURBO 8 MEG PCI 399
 TWIN TURBO 4 MEG PCI 249
 TWIN TURBO TURBO TV 89

NEC

NEC M500 15" 389
 NEC M700 17" 699
 NEC P750 17" 779
 NEC E700 669
 NEC E1100 21" 1099
 NEC P1150 21" 1199



ZIP DRIVE 100 MEG 139
 ZIP DRIVE PLUS 189
 JAZZ DRIVE 1GIG/2GIG CALL
 ZIP CART 10 PACK 109
 JAZZ CART 79
 IOMEGA BUZ 189
 VST PB 3400 ZIP DRIVE 329

LinoColor

Jade 449
 Saphir 1389
 Saphir Ultra 3289
 Opal 4899
 Opal Ultra 6199



GCC ELITE XL-608 1699
 GCC ELITE XL-1212 1399
 GCC ELITE XL-616 2099
 GCC ELITE XL-808 2399
 GCC ELITE XL-1208 2999
 GCC ELITE XL-1208 PLATE 3999

RASTEROPS

SUPERSCAN MC-620 459
 SUPERSCAN MC-6315 599
 SUPERSCAN MC-7515 849
 SUPERSCAN MC-801 1149
 SUPERSCAN MC-801-HR 1299



STYLUS COLOR 600 259
 STYLUS COLOR 800 369
 STYLUS COLOR PHOTO 369
 STYLUS COLOR 1520 769
 STYLUS COLOR 3000 1699
 EXPRESSION/636/EXEC 729
 EXPRESSION/636/ART 929
 EXPRESSION/636/PRO 1249

All prices are cash discounted. Prices subject to change without notice. Not responsible for typos. An asterisk "*" denotes refurbished product.

Apple Centris 650

24/230/Ethernet

- 25MHz 68040
- 24MB RAM
- Built In Ethernet
- 3 Nubus Slots
- 230MB Hard Disk
- Used 30-day warranty



- Add Atlantic Tech Speakers \$49
- Add Extended Keyboard \$49
- Add Apple 16" Trinitron \$199

FROM **\$329**

QuickTake 150

- New 1 year warranty
- All manuals/cables included
- Retail Box



- Leather Travel Case only \$19 with purchase
- Add Connection Kit for Windows only \$9

ONLY **\$129**

Apple Video Upgrades



- Apple TV Tuner Card** \$49
TV for most Performa systems
- Apple Video System** \$49
Video Capture for most Performas
- Apple MPEG Media System** \$49
Full Screen, Full Motion MPEG Video
- Apple Presentation System** \$99
Mac to TV Conversion for any Mac
- PowerMac AV Card** \$99
2MB VRAM for 6100, 7100, 8100

FROM **\$49**

- Apple TV Tuner Card** \$49
TV for most Performa systems
- Apple Video System** \$49
Video Capture for most Performas
- Apple MPEG Media System** \$49
Full Screen, Full Motion MPEG Video
- Apple Presentation System** \$99
Mac to TV Conversion for any Mac
- PowerMac AV Card** \$99
2MB VRAM for 6100, 7100, 8100

OWN THE FASTEST MAC ON THE PLANET!

"Over 1100 on MacBench!," says Mac Monkey

Daystar Millennium

- Millennium 132 0/0/4xCD/no video \$1399
- Millennium 200 0/0/8xCD/no video \$1699
- Millennium 400 0/0/8xCD/no video \$1999
- Millennium G3 310 0/0/8xCD no video \$2999
- Add 64/4GB Narrow/Zip/4MB PCI \$499
- Add 128/Dual 4GB Wide Array/Zip/PCI SCSI/8MB PCI \$1799
- Add 128/Dual 9GB Wide Array/Jaz/Dual PCI SCSI/8MB PCI Video/100Base-T \$2299

All Machines are built to YOUR specifications. You choose the processor, hard disk, video card and extra options you want for a truly customizable MacOS machine.



FROM **\$2999**



MacWorks 800-482-2705

"Low Prices, Great Service... And A Monkey!"

Voice 913-599-6227 • Fax 913-599-6111

Apple PowerMac 6100 DOS Card Kit

- DOS Included
- All manuals/cables included
- Retail Box
- Full Warranty
- Fits 6115/6116 also
- Windows Available

FROM **\$59**

6100 Nubus Adpater

- Allows Third Party Video Cards in 6100
- New in box

\$149

Apple OneScanner

- 300 dpi
- 8 1/2 x 14 flatbed
- 24 bit grayscale
- New in box



ONLY **\$49**

USED

- Daystar 830 & 040 Upgrades from \$29
- Quadra 610 - 12/230/CD \$399
- Quadra 700 - 4/160 \$399
- Quadra 800 - 8/230/CD \$499
- PowerBook Duo 230 - 12/120 \$399
- Duo Dock - Original/Upgraded \$199/\$249
- Ilcx Bundle - 4/80/13" RGB/Kybd. \$279
- Ilxi Bundle - 5/80/13" RGB/Kybd. \$299
- Ilci Bundle - 4/80/13" RGB/Kybd. \$349
- Macintosh 13" RGB Monitor \$179
- Apple 14" Color RGB \$229
- Apple 16" Color Trinitron \$299
- LaserWriter III/IIlx - 300 dpi \$199/\$249
- LaserWriter III/IIg - 300 dpi \$499/\$599

PARTS & ACCESSORIES

- Fax Card for LW Pro 810 \$99
- ClarisWorks 3.0/FileMaker 1.0 \$19
- AppleShare 4.1 - upgradeable \$299
- Apple Extended Keyboard - used \$49
- Apple Desktop Bus Mouse - new \$49
- Performa 630->640 Upgrade \$129
- GV 19.2 Internal Modem for 500 series PB \$99
- Manual/Auto Inject Floppy \$79
- PB 190 Infrared Card Upgrade \$29
- PB 190/5300 8MB Ram Module \$69
- PB 500 8MB/Duo 8MB Ram Module \$39
- Ilcx/650/7100 Power Supply \$89
- Duo Dock Power Supply \$119
- 800/840/8100 Power Supply \$129

Atlantic Technology M105/M110 Speaker System w/Subwoofer



- Includes Stands
- Ranked by CNET
- "Incredible Sound"

\$99

Apple Geoport Telecom Pod

- 28.8 Modem
- 14.4 Fax
- M3127LLC
- 1 year warranty
- Includes software
- Works with AV and most PowerMacs



ONLY **\$19**

Apple Printer Accessories

- StyleWriter Ethernet Adapter \$49
- M4775LL/A
- ColorStyleWriter 2200 Battery \$29
- M4084G/A
- LW 12/640 500 Sheet Feeder \$99
- M4682G/A
- LW Pro 500 Sheet Feeder \$99
- M6550G/A
- LW Pro Envelope Feeder \$99
- M6510G/A
- LW Select 250 Sheet Feeder \$129
- M2041G/A
- Portable SW Auto Sheet Feeder \$29
- M1736G/A
- Color LW Universal Cassette \$69
- M5982G/A
- LW 16/600 500 Sheet Feeder \$129
- M2650G/A

FROM **\$49**

Check Website for Others

Newton Accessory BLOWOUT!!!

- Many software titles available
- See website for details
- Some of the following:

- ExpensePlus
- FilePack, PowerForms
- Fodor's Travel Manager
- Word Battery Pack
- Battery Recharger
- Battery Source Kit
- Leather Carrying Case



FROM **\$9**

APPLE/DAYSTAR 604 & 604e UPGRADE CARDS

for 7300, 7500, 7600, 8500, 8600, 9500 & 9600

- Apple PowerPC 604/132 \$49
- Apple PowerPC 604e/166 \$129
- Daystar PowerPC 604e/200 \$199
- Apple PowerPC 604e/200MP \$599

FROM **\$49**

WE GUARANTEE
THE BEST PRICES!

MediaGuide
BUY/SELL/TRADE

Prices Listed
Reflect a 3%
Cash Discount

OLDER MACS

Mac Plus 1/0.....\$49	SE 4/40.....\$79
SE/30 4/40.....\$149	Classic 4/40...\$119
Mac II 4/40/Video...\$69	LC 10/40.....\$119
IIcx 8/40/Video.....\$99	IIsi 5/40.....\$99
IIci 8/80.....\$149	IIvx 8/160.....\$179

Ask about our bundle specials
for IIsi, IIcx, or IIci's...from only \$249!

QUADRA & CENTRIS

Mac IIfx 8/160.....\$199	C610 16/500...\$349
Q605 8/160.....\$349	Q610 16/500...\$399
Q630 16/250.....\$399	C650 16/230...\$399
Q650 16/230.....\$449	Q700 8/230...\$399
Q800 16/230.....\$479	Q900 8/230...\$499
Quadra 660AV 16/230/CD.....\$499	
Quadra 840AV 16/230/CD.....\$649	

POWER MACS

6100/60 8/230/CD.....\$549
7100/66 8/230/CD.....\$649
8100/80 8/500/CD.....\$799
7200/75 8/500/CD.....\$649
7200/90 8/500/CD.....\$749
7500/100 16/1gig/CD.....\$1099
Many other Power Macs in stock.....CALL!!

POWERBOOKS

PB 140 4/40.....\$299	PB 170 8/80...\$499
Powerbook 165 12/160/14.4.....\$599	
Powerbook Duo's.....from \$199	
Powerbook 520 12/160/19.2.....\$799	
Powerbook 540c 12/320/19.2.....\$1099	
PB 5300cs / 5300c / 5300ce.....CALL!	

MONITORS & PRINTERS

Apple 12" Mono...\$89	Apple 12" RGB...\$119
Apple 13" RGB...\$149	Apple 14"....\$179
Apple 15" MS...\$299	Apple 16" RGB...\$349
Apple 17" MS...\$499	Apple 20" MS...\$899
Imagewriter II...\$99	Laserwriter...\$99
Laserwriter IIInt...\$199	LW IIIntx...\$249

DRIVES, PARTS & MISC.

External hard drive case w/cable.....\$29	
Newton 120 (new) with software.....\$199	
8-bit NuBus video card...\$39	24-bit...\$99
Ethernet cards...\$29	IIsi NuBus adapt...\$29
Global Village 14.4 for Powerbook 1xx...\$39	
800K floppy...\$25	1.44 floppy from \$69
256K Level-2 cache for 6100 & 7100.....\$12	
Logic boards, Power supplies, RAM — CALL!	
Parts, Accessories, other CPUs — CALL!	

Call toll free: (800) 463-0686

Fax: (303) 571-5020 • Local & Int'l: (303) 571-1900

Hours: M-F 8-6, SAT 10-5 MST • 777 N. Santa Fe Dr., Denver, CO 80204

E-mail: Sales@MediaGuide.com • http://www.mediaguide.com

CIRCLE 443 ON READER SERVICE CARD

**POWERBOOK
PRODUCTS**

IDE PowerBook Drives

For use in PB 3400, 2400, 1400, 6300, 190, 120 & Duo 2300
1.4 GB TOSHIBA \$ 199 3yr
2.1 GB TOSHIBA \$ 229 3yr
3.0 GB IBM \$ 299 3yr
4.0 GB IBM \$ 489 2yr
5.0 GB IBM \$ 589 2yr
8.0 GB IBM \$ CALL 3yr

SCSI PowerBook Drives

For use in PB 600 Series, Duo 200 Series, PB140-180c (except 180)
240 MB APPLE \$ 149 1yr
810 MB TOSHIBA \$ 399 3yr

O'Grady's Macworld Best of Show Pick
MadsonLine AC adapter
for PB 3400, G3, 2400 & 1400
only \$85

Don't Trash your old drive!
Use our PC-card IDE case and save your megabytes \$129

half the size/weight of Apple's adapter!

All MCE PowerBook hard drives carry a 30 day Money Back Guarantee & ship with Torx Tool, if needed, illustrated installation manual, Anti-static wrist strap. SCSI Drives ship w/ Drive7 Utility Software.

newertech

NUpowr 1400/183	- \$ 479
VIEWpowr 1400 (16-bit video)	- \$ 169
NUpowr 500/183c (0MB)	- \$ 579
NUpowr 500/183c (24MB)	- \$ 759
NUpowr 500/167 (8MB)	- \$ 489

MCE powrUP 500/183c (32MB) Bundle
Includes: NUpowr 500/183c (0MB), 32MB module & Toshiba 810 MB 2.5" SCSI HD \$ 1049



FREE
with every order over \$100

ADB Flexlight - Great for dark lecture halls, planes, cars or in the field \$29 separately



See our complete line of PowerBook Products & Upgrades at

www.PowerBook1.com

1-800-5000-MAC • 714-458-0800 • fax 714-458-1803

30 Hughes Suite 203 • Irvine, CA • 92618

Visa / MC / AmEx / Discover / P.O.'s

Mitsui Blank CDs
as low as \$1.99 each!

CD Recorders

4x2x6 Yamaha CDRW	\$499
4x6 Yamaha	\$499
4x8 Panasonic	\$399

Add \$60 for external

CD-R Duos

JAZ2CDR (4x8)	\$859
CD2CDR (12x/4x8)	\$799
DAT2CDR (2 Gig/4x8)	\$995

All Duo prices external

Multi CD Copiers

Call for price & config.

Media (CDs minimum 10)

Media One	\$2.19
Mitsui	\$2.49
CD-RW	\$19.99
Jaz Cartridges	\$89.95

Software

Copy Cat (multi CD)	\$199
Toast	\$79
Gear	\$59

CD Printer

Super Image MP600 ... \$929

Our web catalog: www.copycatshop.com

What's the Big Deal?

NEW! CD-Rs From **\$399**

Complete Kits **\$539 & Up**

Standalone Duplicators Available With SCSI & DAT Audio Inputs **\$1395**

CD Copiers We'll build the size you need. Call for prices and configurations.

Jaz 2 CD-R **\$799 & UP**

4x8 CD-R II **\$859**

Prints on CDs or Paper! **\$929** 2 in 1 printer!

Order Toll Free **1-888-663-3121**

Open Mon-Fri 7 am - 7 pm 760.510.9880 Voice 760.510.9888 Fax



\$300 Trade-in on your 040 MAC*

Push, Pull or Drag Trade-in

*Minimum Requirements: 8/80 Configuration • Unit must be fully functional

Performa 6400/180

- 16/1.6/8xcd
- Factory Refurbs
- PPC 603ev

\$699*

Powerbook 5300cs

- 603e 100MH-z
- 8/750
- Dual Scan screen

\$749*

PowerMac 7200/90

- PPC 601 90MH-z
- 16/500/4xcd
- 2MB VRAM
- 3 PCI slots

\$699*

P6200/75

- 603 75MH-z
- 8/1GB/CD

\$449*

Powerbook 190cs

- LC040 33MH-z
- 8/500
- Dual Scan screen

\$699*

P6300/100

- 603e 100
- 16/1GB/CD

\$549*

NEC Silentwriter 1765

- 17 pages per minute
- Ethernet, local-talk & parallel ports for easy networking
- Postscript Level 2

BRAND NEW \$999

TEXAS INSTRUMENTS MICROLASER PRO E

- 600 dpi
- 12 PPM
- Localtalk and Parallel
- Postscript Level 2

BRAND NEW \$749

LC 580

- 68LC040-33MH-z
- 8/800 Config.
- 14" Built-in Screen

\$799 BRAND NEW!
\$949 with Internal 4X CD

POWERMAC 7200/75 LOGIC BOARD

\$149 BRAND NEW!

Logic board with Power Supply... Only \$299.00

Performa 5200

- 75-MHz PowerPC™ 603
- Internal 14.4 fax/modem
- Built-in Display
- Keyboard & mouse

\$899 8/800/4XCD Refurbished

Performa 6300/100

- 100-MHz PowerPC™ 603e
- Internal 14.4 fax/modem
- 15" Apple Display
- Keyboard & mouse

\$1099 16/1.2GB/4XCD
Add a 16" Apple Trinitron for only \$100!

Personal NT to NTR Upgrade

Turn your Personal NT printer into a Personal NTR with a simple logic board upgrade. The NTR features PostScript Level 2 and a fast RISC processor!

NEW W/EXCHANGE ... \$79

ATI XCLAIM VR With TV

- Features QuickDraw 3D RAVE acceleration
- Supports resolutions up to 1152x870
- XCLAIM TV tuner allows your Mac to receive broadcast television signal.

TV OPTION AVAILABLE SEPARATELY FOR \$69.

AT WITH TV OPTION ... \$249

QuickTake 200

Store high-quality 24-bit images on a removable 2MB data card. 640x480 resolution. LCD display.

RECONDITIONED \$449

PowerBook 150

- Refurbished
- 33-MHz '030 processor
- 8MB RAM, 120MB HD
- passive-matrix grayscale

\$649

Javelin Video 3240XL PCI

- accelerated multimedia card for PCI PowerMacs
- 2MB VRAM onboard
- upgradeable to 4MB
- supports resolutions up to 1600x1200 pixels
- Built-in accelerations for video playback.
- QuickDraw™ and QuickTime™

NEW OEM \$99

Macintosh CPUs

*Performa 635 4/250/.....	\$499
**Performa 5200 8/800/4XCD	\$899
*Centris 650 4/0 (1C040 processor)	\$499
*Quadra 660w 4/0	\$549
*Quadra 840w 0/0	\$749
*Quadra 800 8/0	\$749
**PowerMac 8500/120 16/1GB/4XCD	\$1599
**WGS 95 16/700/CD	\$999
**WGS 8150-80 8/500	\$1499
**WGS 9150/120 16/1GB/CD	\$1799

Logic Boards on Sale

*Performa 600	\$129
*Performa 630	\$199
*Performa 6200	\$299
*LC	\$99
*LC II	\$129
*Mac IIci	\$129
*Quadra 800	\$399
*Quadra 840AV	\$449
*Quadra 950	\$449

More Logic Board Upgrades

*LaserWriter II/STX to IIfx .. exch. \$399 NTR299 STX	
*Mac II or IIfx to IIfx .. exch. \$249	
IIfx to Centris 650 .. exch. \$299	

Video Cards

E-Machines DoubleColor SX 8-bit NEW	\$99
RasterOps 24MX NEW	\$199
Radius PrecisionColor 8/1600 PCI NEW	\$349
Micron Xceed for Performa	\$299
**6100 series AV Card with adapter	\$349
**PowerMac HPV VRAM Card (1MB VRAM)	\$179
**Apple QuickDraw 3D Accelerator Card PCI	\$199

NuBus Adapters & Misc.

Quadra 660AV NuBus Adapter	\$49
Quadra 610 NuBus Adapter	\$49
*Quadra 610 DOS Compatibility Card	\$99
Apple Color OneScanner	\$199
Apple Color OneScanner 600/27	\$349
UMAX UG840 Scanner NEW	\$299
Epson ES-600C NEW	\$349

Monitors

Apple 14" A/V NEW	\$349
*Apple MultiScan 17"	\$499
**Radius IntelliColor Display/20c NICE!	\$1299
**Hewlett-Packard 17"	\$449
**Hewlett-Packard 20"	\$649

Printers

**Apple StyleWriter 1200	\$139
*Apple LaserWriter 16/600PS	\$1199
**Apple Personal LaserWriter 300	\$329
*Apple Personal LaserWriter NTR	\$549
*LaserWriter IIf w/5MB RAM	\$749
*LaserWriter IIfg w/5MB RAM	\$899

Laser toner cartridges sold separately

Power Supplies

Q610, Q660w, PM 6100	\$199
Q700, Q650, PM 7100	\$169
Performa 630,6200,6300	\$199
PM7200,7500,7600	\$199
Q800, Q840w, PM 8100	\$199
PM 8500	\$399
PM 9500	\$449
PM 5200	\$249
Duo Dock	\$199
LC 575	\$299
Classic, Classic II	\$129

MACINTOSH LOGIC BOARD UPGRADES

PowerMac 8100 to 8500/120 (exchange)	\$999
Quadra 950 to WGS 9150 (exchange)	\$999
PowerMac 7200 to 7500/132 (exchange)	\$699
Quadra 800/640 to PM 8500/132 (exchange)	\$1299
Performa 630 to 6300/100 (exchange)	\$499
Performa 6200 to 6300/100 (exchange)	\$249
Quadra 800 to PowerMac 8100/80 (exchange)	\$599
Quadra 660 to PowerMac 6100/60 (exchange)	\$449
Performa 600/IIfx to Centris 650 (exchange)	\$279

PowerCenter Pro 180 Minitor

- 180-MHz PowerPC 604e • 32MB of RAM, 2GB hard drive • 16X CD
- 2MB VRAM • keyboard & mouse • factory refurbished
- Low-profile with 16/2GB/16XCD Only \$1599!

PowerComputing \$1699

PowerBase 180 LP

- 180-MHz PowerPC 603e • 16MB of RAM, 1.2GB hard drive
- 1MB VRAM, Ethernet
- 8X CD-ROM • keyboard & mouse • factory refurbished

\$899

ORIGINAL APPLE 1.44 FLOPPY

We have original Macintosh floppy drives!

Now \$99 and up

APPLE ADB MOUSE II

The original Apple ADB Mouse II. In stock!

ONLY \$49

NEW Apple CD1200i 8x

- 8x internal drive
- Mounting kit optional
- Upgrade your 2x or 4x

Only \$99!!

PowerPort Mercury

GlobalFax software included. Features data transfer speeds of 19.2Kbps and fax speeds of 14.4Kbps. Fastest standard modem available for the PowerBook 520 series

BRAND NEW! \$129

E-Machines DoubleColor SX

- 8-bit accelerated video
- hardware pan & zoom
- for nubus-based Macs
- virtual screens feature

BRAND NEW \$99

DuoDock Plus Blowout!!!!!!

Get an Original Apple DuoDock for your Duo 210-2300C 1MB VRAM, Ethernet! Make your duo a desktop unit!

RECONDITIONED \$299

MAC ALLY Extended Keyboard

- 105-Key w/Numeric Keypad and F-Keys
- Recessed Power Button
- Compare to Apple Extended Keyboard II

\$29!

SHREVE Systems

WE STOCK MAC PARTS!

1-800-227-3971

FAX (318) 424.9771 • TECHNICAL SUPPORT (318) 424.9887

CUSTOMER SERVICE (318) 424.9791 • PURCHASING/INFORMATION (318) 424.9791

1200 MARSHALL STREET • SHREVEPORT, LOUISIANA 71101

* indicates refurbished
** indicates factory refurbished
Products are refurbished unless indicated as "new". Prices reflect a 2% cash discount and are subject to change without notice. Returns are subject to a 15% restocking fee. Not responsible for typographical errors. Refurbished systems may include like-new components and may also include cosmetic blemishes which do not functionally impair performance of the hardware.

COMPUTER DISCOUNTERS

WE WILL SAVE YOU MONEY - THE TOTAL HARDWARE SOURCE!! NEW, REFURBISHED and DEMO EQUIPMENT IN STOCK. MAC PRINTERS, COMPUTERS & POWERBOOKS IN STOCK NAME BRAND PENTIUM SYSTEMS from \$899 to \$1999

WE BUY USED/DISCONTINUED MAC HARDWARE!
MACINTOSH SPECIALS

POWERBOOKS
PowerBooks 100/500/5300/Duo.....Call \$\$\$
100 Series.....\$350-\$650
Global Village PB PC Card 14.4 Fax modem...\$29
Radius Thunder PC 30/1152 & 1600... \$199/199

66040 PROCESSOR MACS
CENTRIS 610/650.....\$259/299
QUADRA 650 8/230.....\$350
QUADRA 840AV 16/500/CD.....\$695
QUADRA 950 16/250.....\$395

POWERPC PROCESSOR MACS
PowerMac 7100/80 8/250.....\$595
PowerMac 8100/100 16/1GB/CD.....\$799
PowerMac 6100/60 16/250
w/14" Apple Monitor.....\$599

LASERWRITERS
HP Laserjet 5MP.....\$499
HP 4MV/5M/5SIMX.....\$1695/1395/2395
Laserwriter IINT.....\$195
DEC Laser 1152 PS/2 2MB.....\$199

MONITORS
SPECIAL - MAC MONITORS
HP A2094A 20" Sony Trinitron 1152 x 870
@ 75HZ MPR II.....\$399

8383 Leesburg Pike, Vienna, VA 22180
10543 Ewing Road, Beltsville, MD 20705
Tel: (301) 595-0500 Fax: (301) 595-5112
Toll Free # (800) 964-1886
www.computerdiscounters.w1.com

Mac POWER

Sales & Service, Inc.

**BUY • SELL • TRADE
UPGRADE • REPAIR**
New • Used • Refurbished

- Powerbooks
- PowerMacs
- Performas
- MacII-LC
- Monitors
- Printers
- Peripherals
- Ram
- Parts

Call now for best prices!

888-275-POWER
Fax: 408-448-6132
San Jose, California, 95123

MACS & POWERBOOKS

WANTED

TOP \$\$\$ PAID FAST!

MAC Solutions
11933 Wilshire Bl.
W. Los Angeles, CA 90025
www.macolutions.com

Any Quantity
Trade Ups Welcome
FedEx check delivery
We Buy, Sell & Trade
New & Used Macs

(800)80-WE-BUY
Tel: (310) 966-4444 Fax: (310) 966-4433

CIRCLE 447 ON READER SERVICE CARD

Welcome to **MACTICA**.
A fresh new place for fresh new Macs, with discount prices you'll need to see to believe. ▶

G3 PowerMacs	G3 PB
G3/233 \$1740	G3/250 \$4589
G3/266/Zip \$2089	

Mac/PC in one
32/4G/
24xCD

Exclusive! Free RealPC

32/5G/
20xCD/
33.6k

9600/300 850 20" Bundle \$4099
SAVE \$200+



Power Macs
9600/350 64/4G/24xCD/V8 \$3989
9600/300 64/4G/24xCD/V8 \$2889
8600/300 32/4G/12xCD \$2089
(above w/ internal Zip) +\$100
7300/200 32/2G/12xCD \$1389

PowerBook
G3/250 32/5G/20xCD \$4389
3400c/240 16/3G/12xCD \$3189
3400c/200 16/2G/12xCD \$2689
1400c/166 16/2G/CD \$2089
Apple 33.6k PCMCIA +\$195

Competitive pricing; Check for latest price.
Credit cards only 2.5% extra. Attractive volume discount. Intl and resellers welcome.
sales@mactica.com • 650-742-9782

Monitor
20" 850 \$1389
17" 1710 \$680

CPU Upgrade
604e/233 \$350
604e/200MP \$450

Ethernet Card
10/100Base PCI \$39/\$79

LaserWriter
12/640 Toner \$1050
\$110

PowerCity (Motorola Clone)
604e/200 Tower \$1499

- Loaded 64/4G/24xCD
- Identical to StarMax 4000
- 1 year warranty

MACTICA
1-888-666-5147

DFI

20" Sony Color BLOWOUT MODEL!

Model GDM1960 SuperFine Pitch Trinitron Tube .30 DP

- 1 Year Warranty
- 1024 x 768 Refurbished
- Tilt Swivel Base
- Only **\$599!**

We also carry Sony Monitors
19" as low as \$499
17" as low as \$279

Call for Details **800-390-7020**

181 Salem Street, Malden, MA 02148



MacGlobal

SYSTEMS AND PERIPHERALS • SALES AND SERVICE

Performas 410/466/476 Call 550 5/160 \$700 580 5/500/CD \$800 631 8/500/CD \$550 6200 8/1G/CD \$675 5200 8/500/CD \$995	PowerBooks 520 4/160 \$850 520C 12/240/19.2 \$1195 540C 4/320 \$1,395 5300 8/500 \$995
Power Macs 7200 8/500 Call 7500 16/500 Call 8500 16/500 Call	Quadrax 630 8/250 Call 650/800/840/950 Call
Memory 4 MB 72-pin \$29 8 MB 72-pin \$42 16 MB 72-pin \$89	Printers Stylw II \$185.00 Stylw 1200 \$175 Laser 300 \$299 Laser 320 \$490 Laser 4/600 Call
Monitors 14" Color \$195 15" App. Multi. \$265 17" App Multi. \$450 20" GS \$540	

We Buy!

WE REPAIR MACS!

TOP DOLLAR paid for memory, PowerBooks and CPUs!

[800] 722-8864
Phone: [408] 265-6653
Fax: [408] 265-6660

MacGlobal

USED MACINTOSH!



- We match buyers and sellers of used MAC equipment!
- All MAC models available; SE to POWER PC.
- All hardware is tested and includes a limited warranty.
- Qualifying School, Gov't and Fortune 1000 POs Welcome
- We also specialize in used trade-ins

The Computer Exchange

800-304-4639

www.compexch.com

Customer Service
Ph: 404-315-8518
Fax: 404-898-0304
2100 Cheshire Bridge Rd. Ste E Atlanta, GA

UNITED COMPUTER EXCHANGE



Bringing buyers and sellers together since 1992

The Easiest Way to Buy & Sell Used Macs & More!

Internet Systems:

- OnLine Exchange™ Individual-to-individual transactions
- BidMaster™ Volume seller-to-reseller transactions

What's It Worth? Download MacAppraiser 2.x

www.uce.com

800-755-3033

Tel: 770-612-1205 Fax: 770-612-1239
1690-A Enterprise Way Atlanta, Georgia 30067

CIRCLE 445 ON READER SERVICE CARD

CIRCLE 446 ON READER SERVICE CARD

CIRCLE 448 ON READER SERVICE CARD

800 801-4622

EMAIL: SALES@MICROOUTLET.COM

HOURS: Mon-Fri 7 AM to 7 PM PST,

SAT 10:00 AM to 2:00 PM PST



4455 TORRANCE BLVD., #789

TORRANCE, CA • 90503

Phone: 310-533-0496

Fax: 310-320-4807

800 801-4MAC

DESKTOP MACS

Power Mac
8600 / 300
32/4GB/24XCD/ZIP
\$80.00
Per Month

Model	Configuration	Key/Access
63/266 MT	32/6/24xCD/L2/Zip....	\$2650/\$92
63/283 DT	32/4/24xCD/L2.....	1730/60
63/286 DT	32/4/24xCD/Zip.....	2095/73
9600/350	64/4GB/24xCD/L2/Zip....	3650/127
9600/300	64/4GB/24xCD/L2/Zip....	2899/101
9600/200	0/0GB/CD/Key.....	1450/50
9600/250	32/4GB/24xCD/L2/Zip....	2195/76

PowerPC
8600/300 MHz
• 32MB RAM /Zip
• 4GB HD, 24 X CD
• Rasterops SuperScan
21" Monitor
• Keyboard
\$128.00
Per Month, For 36 Months

Model	Configuration	Key/Access
4400/200	32/2GB/12xCD/33.6/DOS...	\$1350/\$47
4400/200	16/2GB/CD.....	1250/44
7300/200	32/2GB/12xCD/L2/Key.....	1495/52
7300/180	32/1.2GB/12xCD/L2/DOS...	1499/52
7300/180	16/2GB/12xCD/L2/Key.....	1299/45
6500/300	64/4GB/CD/Zip/33.6.....	2095/73
6500/275	48/6GB/CD/Zip/SmBusiness...	2499/87
6500/275	32/3GB/CD/33.6/ZIP.....	2075/72
6500/225	32/3GB/CD/33.6/Sony 15"	1725/60
6500/225	32/4GB/CD/33.6.....	1425/50

Power Mac
6500 / 300
64/6GB/CD/ZIP/MD
\$93.00
Per Month

WORKGROUP & NETWORKS

Work Group
9650 / 350
64/2X4GB/CD/AS/ENet
\$226.00
Per Month

WORKGROUP SERVERS

7350/180	48/4GB/12xCD/AShare...	\$3095/107
9650/233	64/4GB/CD/Internet.....	4848/168
9650/233	64/2x4GB/12XCD.....	5128/178
9650/233	64/4GB/CD/DAT/AShare...	5875/204

NETWORK SERVERS

500/132	32/1GB/CD.....	\$ 8725/233
700/150	48/4GB/CD/DAT/UNIX * ..	9248/320
700/150	32/1GB/CD/UNIX * ..	7365/255

* Requires AIX1299/45

LEASING

- Fast Approval • Tax Deductible
 - Very Low Yield Rates
 - Three Buyout Options
 - Business or Personal Leasing
 - Ask for the Leasing Department
- 3 Year Extended Warranty Available!**

POWERBOOKS

PowerPC
63/250 MHz
• 32MB RAM
• 5 GB HD
• 20X CD
• 33.6 Modem
\$159.00 Per Month, For 36 Months

Model	Configuration	Key/Access
63/250	32/6GB/20xCD.....	\$4295/\$177
3400c/240	16/3GB/12xCD/33.6/EN.....	3399/118
3400c/200	16/3GB/12xCD/EN/33.6.....	2899/101
2400c/180	16/1GB.....	2095/73
1400c/166	16/2GB/8xCD.....	1899/66
1400cs/166	16/1.3GB/12xCD.....	1799/62

Power Book
3400c / 240
16/3GB/8XCD/EN
\$111.00
Per Month

MONITORS

Apple
Multiscan 750AV 17"
\$899.00

Apple	Multiscan 15" AV.....	\$ 349
Apple	AppleVision 750.....	799
Apple	AppleVision 750 AV.....	899
Apple	Multiscan 850AV 20".....	1895
HITACHI	Superscan 19" .22mm.....	985
Hitachi	Superscan MC20.....	1325
Hitachi	VisionMaster Pro 21".....	1195
Hitachi	17" 1024 x 1280.....	475
MITSUBISHI	Diamond Pro 911Txm.....	1249
MITSUBISHI	Multisync M700.....	875
NEC	Pressview 21SR.....	3086
NEC	Multiscan 200SE.....	599
RADIUS	Multiscan 200PS.....	815
SONY	Optiquest 773 17".....	449

VIDEO EXPANSION

Video Cards

ATI	Xclaim 3D 4mb V-card.....	\$ 129
ATI	Xclaim 3D 8mb V-card.....	225
ATI	Twin Turbo 2mb V-card.....	199
IMS	Twin Turbo 4mb V-card.....	325
IMS	Twin Turbo 8mb V-card.....	465
Matrox	Millenium 4mb V-card.....	236
Matrox	Millenium 8mb V-card.....	345
Number 9	Imagine 128 8mb V-card.....	699
Radius	Thunder 30/1800.....	479
Radius	Thunder 30/1920.....	619
Radius	Videovision V2.0.....	2249
TrueVision	Targa 1000 w/Premiere.....	1599
TrueVision	Targa 2000.....	2939
TrueVision	Targa 2000 Pro.....	3399
VRAM	1MB 7300,8600,9500,9600 Series.....	\$ 25

PRINTERS

Apple
LaserWriter 8500
\$2349.00

Apple	Color Stylewriter 6500.....	\$ 489
Apple	Color Stylewriter 4500.....	349
Apple	LaserWriter 12/640.....	1095
Apple	MD1000 Micro Dry Mac/PC.....	389
EPSON	Stylus Color 800 1440dpi.....	389
EPSON	Stylus Color 600 1440dpi.....	259
EPSON	Stylus Photo 6 Color/720dpi.....	439
EPSON	Elite XL 808 800 DPI.....	2699
EPSON	Elite XL 1208 1200 DPI.....	5619
EPSON	LaserJet 6MP.....	879
EPSON	Color LaserJet 5M.....	4885

SCANNERS

Microtek ScanMaker
E6 Pro/Full Photoshop
\$495.00

AGFA	Arcus II Bundle.....	\$ 1525
AGFA	SnapScan 800.....	379
AGFA	SnapScan 310.....	225
AGFA	Express. 636 Artist.....	889
AGFA	Express. 636 Executive.....	739
AGFA	Express. 636 Profess.....	1255
AGFA	5P Mac 600 dpi LE Photo.....	299
AGFA	Linocolor Jade 600 dpi.....	435
AGFA	Scanmaker E3.....	149
AGFA	Scanmaker III w/Photo.....	1325
AGFA	Astra 1200s 600 dpi.....	235
AGFA	Astra 1200s w/PhotoShop.....	429
AGFA	Powerlook II & Trans.....	1230

KEYBOARDS / MODEMS

KEYBOARDS

Generic	Design Keyboard.....	\$ 69
Generic	Extended Keyboard II.....	89
Generic	Extended Keyboard.....	39

MODEMS

Farallon	Netopia (ISDN).....	\$ 329
Global Village	Teleport 56K Fax v.34 K2.....	159
Global Village	Teleport 56K Fax v.34 K2.....	159
Global Village	PowerPort 56K PC Card.....	359
Global Village	PowerPort Plat 28.8 PC Card.....	219
Supra	Express Modem 33.6.....	99
Supra	ExpressFax Modem 56E V.34.....	129
Supra	Express 56S Speakerphone.....	139
U.S. Robotics	Sportster 28.8 PC Card.....	199
U.S. Robotics	Sportster 56K X2.....	139
Zoom	33.6 Int. 14.4 Fax PC Card.....	155

PERIPHERALS

CACHE CARDS

256K	L2 Dimm 6400/4400 Series.....	\$ 49
512K	L2 Dimm 6400/4400 Series.....	79
256K	L2 Dimm, 7200-8500 Series.....	49
512K	L2 Dimm, 7200-8500 Series.....	69

REMOVABLE CARTRIDGES

Nomai	200MB or 270MB.....	\$ 25
Verbatim	200MB.....	29
SyQuest	200MB / 230MB.....	29
SyQuest	EZ 135MB / 230MB.....	14/22
MEGA	Zip 100MB/10 Pack.....	16/14
MEGA	JAZ 1GB Cart/5 Pack.....	83/399

DRAWING TABLETS

Wacom	ArtZ II 6x8 w/Ultra Pen.....	\$ 281
Wacom	ArtZ II 12x12 w/Ultra Pen.....	390
Wacom	ArtZ II 12x18 w/Ultra Pen.....	645
Wacom	ArtZ II 18x25 w/Ultra Pen.....	1817

MEMORY

SALE!

16MB	72 Pin Simm.....	39
32MB	72 Pin Simm.....	69
32MB	168 Pin Dimm 60ns.....	69
64MB	168 Pin Dimm 60ns.....	129
128MB	168 Pin Dimm 60ns.....	425
32MB	168 Pin Dimm SDRAM G3.....	69
64MB	168 Pin Dimm SDRAM G3.....	139
128MB	168 Pin Dimm SDRAM G3.....	379
16MB	168 Pin Dimm 60NS 3.3V.....	45
32MB	168 Pin Dimm 60NS 3.3V.....	78
64MB	168 Pin Dimm 60NS 3.3V.....	145
16MB	Powerbook G3.....	49
32MB	Powerbook G3.....	109
64MB	Powerbook G3.....	189
128MB	Powerbook G3.....	395
16MB	Powerbook 1400 Module.....	75
24MB	Powerbook 1400 Module.....	109
32MB	Powerbook 1400 Module.....	119
16MB	Powerbook 2400c Module.....	78
32MB	Powerbook 2400c Module.....	145
64MB	Powerbook 2400c Module.....	259
32MB	Powerbook 3400c Module.....	99
64MB	Powerbook 3400c Module.....	189
128MB	Powerbook 3400c Module.....	379

HARD DRIVES

Quantum Stratus 4.3 GB
\$359.00

Quantum	Stratus 2.1 GB.....	\$ 219
Quantum	Stratus 2.1 GB.....	259
Quantum	Stratus 3.2 GB.....	252
Quantum	Stratus 3.2 GB.....	289
Quantum	Fireball 4.3 GB.....	369
Quantum	Fireball 4.3 GB.....	409
Quantum	Atlas II 4.5 GB N.....	545
Quantum	Atlas II 4.5 GB W.....	539
Quantum	Atlas II 9.0 GB N.....	849
Quantum	Atlas II 9.0 GB W.....	849

Seagate

Seagate	Barpacuda 4 2.0 GB.....	389
Seagate	Barpacuda 4 4.5 GB N.....	529
Seagate	Barpacuda 4 4.5 GB W.....	549
Seagate	St34501N Cheetah 4.5GB.....	589
Seagate	St34501W Cheetah 4.5GB.....	609
Seagate	Barpacuda 9.0 GB N.....	689
Seagate	Barpacuda 9.0 GB W.....	729
Seagate	Elite 23.0 GB N.....	2000
Seagate	Elite 23.0 GB W.....	2095

REMOVABLE DRIVES

MEGA

MEGA	Zip w/100MB Cartridge Ext.....	\$ 149
MEGA	Zip 100MB & Cartridge Int.....	168
MEGA	Jaz 1GB Retail & Cart. Int.....	275
MEGA	Jaz 1GB Generic & Cart. Ext.....	359
MEGA	Jaz 1GB Retail & Cart. Ext.....	399
MEGA	Jaz 1GB Retail & 4 Cart. Ext.....	599

SyQuest

SyQuest	EZ 230 MB & Cartridge.....	149
SyQuest	Syjet 1.5GB & Cartridge Int.....	279
SyQuest	Syjet 1.5GB & Cartridge Ext.....	289
SyQuest	Syjet 1.5GB & Cart. House Ext.....	289
SyQuest	640 MB Dynamo Int.....	369
SyQuest	640 MB Dynamo Ext.....	449
SyQuest	230 MB PowerMo Ext.....	349
SyQuest	2.8 GB PowerMo Ext.....	1699
SyQuest	4.8 GB Apex Ext.....	1150
SyQuest	230MB Opt. Dr. PB 3400.....	435
SyQuest	230MB Opt. Dr. PB 1400.....	399
SyQuest	6R x 2W Rewritable.....	599
SyQuest	8R x 4W CDR Rewr. w/Toast.....	555
SyQuest	RB/WZ Rewritable w/Toast.....	619
SyQuest	Jaz / Sony 6 x 2 Combo.....	408

EXPANSION CARDS / CAMERAS

DOS CARDS

Apple	Pentium 166mhz.....	\$ 650
Apple	Pentium 100mhz.....	499

PROCESSOR UPGRADE CARD

Never Tech.	Max Power 604/200 Mhz.....	\$ 285
Never Tech.	Max Power G3 for PM 6100.....	499
Never Tech.	Max Power G3 for PM 71/8100.....	599
Never Tech.	Max Power G3/250.....	899
Never Tech.	Max Power G3/275.....	1769
Never Tech.	NuPower PBK 500 187 Mhz w/8MB.....	509
Never Tech.	NuPower PBK 500 183 Mhz & Cache.....	459

DIGITAL CAMERAS

AGFA	Ephoto 307.....	\$ 289
AGFA	Quicktake 200.....	250
SONY	DSC-F1 w/Flash 4mb Color LCD.....	679

Due to publication time, the advertising prices may vary. All prices includes cash discounts. Not responsible for typographical errors. Shipping and service fees are non-refundable. No sales tax outside of CA. All returns subject to 15% restocking charge. All returns must have an authorization number (R.M.A.) Graphics shown do not necessarily represent actual product.



THE GOOD, THE BETTER

VISIT US ON THE NET AT www.applemacnet.com

- 1-CONSULT UPDATED PRICES! 2-ONLINE CATALOG, OFFERS & ORDERING 3-CREDIT CARDS, C.O.D., P.O. & LEASING
4-CUSTOMER SERVICE 5-WORLDWIDE SHIPPING ON THE FLY 6-SCHOOLS, UNIVERS. & US GOVERN. WELCOME

NEW G3 SERIES

- G3*233MHz/32MB/4GB/24XCD.....\$1,799.00
- G3*266MHz/32MB/4GB/24XCD/Zip Drive(Desktop).....\$2,199.00
- G3*266MHz/32MB/6GB/24XCD/Zip Drive/AV card(Minitower)\$2,699.00

- ### Power Macs
- 7300 200MHz/16MB/2GB/12XCD.....\$1,499.00
 - 7300PC 200MHz/16MB/2.0GB/8xCD.....\$2,199.00
 - *8600 300MHz/64MB/4GB/Zip Drive/24XCD.....\$2,299.00
 - *9600 300MHz/64MB/4GB/24XCD.....\$call

- ### Power Mac 6500 series
- 6500 225MHz/32MB/3GB/12XCD/33.6Mdm.....\$1,399.00
 - 6500 250MHz/32MB/4GB/12XCD/56kMdm/Zip drive.....Call
 - 6500 250MHz/48MB/4GB/12XCD/56kMdm/Zip(Office).....\$1,999.00
 - 6500 275MHz/32MB/4GB/12XCD/56kModem/Avid cinema!.....\$2,099.00
 - 6500 300MHz/64MB/4GB/12XCD/56kMdm/Zip drive.....\$2,199.00

- ### PowerBooks
- G3 *250MHz/32MB/5GB/20XCD/33.6 enh. modem.....\$4,999
 - 1400c *133MHz/16MB/2GB/8XCD/128 k L2Call
 - 1400c *166MHz/16MB/2GB/8XCD/128 k L2Call
 - 2400c *180MHz/16MB/2GB/8XCD/128 k L2Call
 - 3400c *200MHz/16MB/2GB/12XCD/33.6 modem.....Call
 - 3400c *240MHz/16MB/3GB/12XCD/33.6 modem.....Call

- ### PDA
- Message Pad 2000 *162MHz 5MB/8MB ROM/4MB Flash RAM...\$699
 - Message Pad 2100 *162MHz 8MB/8MB ROM/4MB Flash RAM...\$899

You don't have to expend thousands of dollars to publish your site on the Internet

7250/120
 ONLY \$999
 •16MB RAM
 •8XCD ROM
 •1.2 GB Hard Disk
 •10Base T Ethernet card
 •WorkGroup Server CD
 •Pre-Installed software
 Also: Apple 7250 w/ Internet Software CD.....\$1,199

UMAX COMPUTERS

\$900/200
 32MB/CD/33.6 Modem
 ONLY \$1,899
 2GB

UMAX SUPER DEAL!
 CALL FOR OTHER MODELS UPDATED PRICES.
(After manufacturer's rebate!)

Graphic Tablets

4"X5" Art Pad

•Superior Control & Feel.
 •Easy to Use & Affordable
 •Erasing UltraPen
 •Take full advantage of today's graphic softwares

BEST BUY \$129.

- Art Z II 6"X8".....289.00
- Art Z II 12"X12".....389.00
- Art Z II 12"X18".....589.00
- Art Z II 18"X25".....1,599.00
- Ultra Pen.....63.00
- 4-button puck.....35.00

Digital Cameras

RICOH RDC-300

•4MBmemory/38mm lens
 •Stores up to 100 images
 •640X480
 •NTSC-Out
 •Auto
 •Flash

\$399

- DS-300 (1280X1000).....1,999.00
- Kodak DC-120 (1280X960).....699.00
- DC-210 (1152X864).....799.00
- Minolta RD-175 (1528X1146/lens).....4,999.00
- Olympus D-320L (1024X768).....619.00
- Polaroid PDC-3000 (1600X1200).....Call

Memory Super Hot Deal

32MB RAM \$75
 SIMMS

SIMMS	DIMMS
16MB \$37	16MB \$38
32MB \$75	32MB \$79
64MB \$159	64MB \$149
also SDRAM for G3: 32MB \$89	128MB \$399
64MB \$189	
128MB \$399	

Monitors

- ### Apple
- Multiscan 15AV 15".....\$369.00
 - Multiscan 720.....\$649.00
 - Multiscan 750AV.....\$849.00
 - Multiscan 850 20".....\$1,499.00
 - Multiscan 850AV 20".....\$1,649.00

Sony 17" CPD200ES \$599.

- ### Sony
- CPD-100 ES 15".....\$339.00
 - CPD-200 ES 17".....\$599.00
 - CPD-100 GS 15".....\$369.00
 - CPD-200 GS 17".....\$689.00
 - CPD-400 PS 19".....\$1,169.00
 - GDM-SE2T 20".....\$1,579.00
 - GDM-500 PS 21".....\$1,759.00

- ### Viewsonic
- E655 15".....\$289.00
 - 15GS 15" (Graphic Series).....\$339.00
 - 17EA 17".....\$513.00
 - 17GS 17" (Graphic Series).....\$569.00
 - G800 20" (Graphic series).....\$999.00

Printers

Epson Stylus 800 \$339

-
- ### Apple
- Laserwriter 4/600.....\$639.00
 - Laserwriter 12/640.....\$1,099.00
- ### Epson
- Stylus Photo.....\$429.00
 - Stylus Color 600.....\$249.00
 - Stylus Color 800.....\$339.00
 - Stylus Color 1520.....\$719.00
 - Stylus 3000 w/postscript.....\$1,699.00
- ### HP
- DeskJet 340 (w/Mac Adapter).....\$299.00
 - LaserJet GMP.....\$859.00
 - LaserJet 5M (6MB).....\$1,499.00
 - DeskJet 1600CM.....\$1,599.00
 - ColorLaserJet 5M.....\$4,799.00

Scanners

Agfa SnapScan 300 \$269



- ### Agfa
- SnapScan 310.....\$199.00
 - SnapScan 600.....\$379.00
 - StudioStar (Photoshop full).....\$749.00
 - StudioStar (Photoshop LE).....\$699.00
 - Arcus II w/transp. adapter.....\$1,299.00
 - Agfa DuoScan(spec. conf.).....\$3,399.00

- ### Epson
- Expression 636 Artist.....\$979.00
 - Expression 636 Professional \$1,299.00
 - Expression 836 XL (12X17).....\$2,299.00
 - 836 XL transparency adap.....\$499.00

Umax Astra 610

Only \$159.

- ### Umax
- Astra 1200S.....\$259.00
 - Astra Transp. Adapter.....\$179.00
 - Power Look II (Photoshop).....\$1,299.00

MICROTEK

Better Images Through Innovation.

ScanMaker V300

BEST BUY \$129.

- 24-bit color depth
- Single-pass speed
- 300x600 dpi optical resolution
- ScanWizard™ scanner controller soft.
- Image-editing software/OCR software

SCANMAKER E3 FOR ONLY \$149

- 35T 35MM Slide.....\$699.00
- ScanMaker E6(SOHO).....\$279.00
- ScanMaker III.....\$1,299.00

Modems

Supra 56k

\$135.

- ### Apple
- Video Phone.....\$259.00
- ### Farallon
- Netopia™ 412 ISDN Modem.....\$299.00
 - Netopia™ 440 Internet Router.....\$799.00
- ### Global Village
- 56Kbps Teleport K56 Flex ext.....\$149.00
 - 56Kbps Teleport K56 X2 ext.....\$149.00
 - 56Kbps PC card K56 flex.....\$259.00
 - 56Kbps PC card Ethernet.....\$399.00
- ### Supra
- VSupra Express 56e.....\$135.00
 - VSupra Express 56e SP.....\$145.00

- ### U.S. Robotics/3COM
- Sportster 56k(2X tech).....\$139.00
 - Sportster 56k(2X tech) Voice.....\$149.00
 - 33.6 k PC Card upg. to 56k.....\$179.00
 - ISDN 128Kbps PC Card.....\$499.00

*After manufacturer's rebate!

Digital Video

Photo DV™ & Moto DV™ Starting at \$95.

FireWire Technology

- Video capture in real-time, full-motion or still-video, edit, add effects and save back to tape w/ no loss!
- iCamcorder not included! *MotoDV™ upgrade!
- Radius Moto DV w/ FireWire Card Full-Motion Video Capture.....\$439.00
- Radius Photo DV Still-Image Video Capture.....\$439.00

Media/Storage

ZIP

PRICE LEAS \$129

- Zip drive w/ 1 cartridge.....\$129
- Zip 100MB cart. (10-pack).....\$125
- Zip Plus drive(6 soft. pack).....\$195
- 100MB Zip cartridge.....\$13

Jaz Drive 1GB

PRICE LEAS \$369

- Jaz Drive w/ 1 cartridge.....\$369
- 1GB Jaz Cartridge.....\$77
- 2GB Jaz Drive.....\$589
- 2GB Jaz Cartridge.....\$129
- JAZ & CD-RECORDER DUO Jaz Drive & LaCie 2X/6X CD-R.....\$799
- SYJET & CD-RECORDER DUO SyJet 1.5G & LaCie 2X/6X CD-R.....\$799

CALL 1-800-404-9976

Schools & Corp. P.O.s are Welcome Customer Service Toll-free number : 1-800-743-2998 MacNet is not responsible for typos!
 ALL PRICES ARE CASH DISCOUNTED. Prices & product availability subject to change without notice - Any merchandise returned is subject to a restocking fee! When returning, call for a RMA# first! Thank You!

AND THE BEST DEALS ARE HERE!

Software

Business

Microsoft Office 4.2.1
Full version

\$299.

Microsoft Office 4.2.1 (full version).....\$299.
Office 4.2.1 (upgrade).....\$199.
Microsoft Word 6.0.1 (full version).....\$269.
Microsoft Excel 5.0 (full version).....\$269.
Microsoft Excel 5.0 (upgrade).....\$119.

Design / Graphics

Adobe Photoshop 4.0
Upgrade

\$129.

Adobe Systems
PageMaker 6.5 (full version).....\$389.
PageMaker 6.5 (upgrade).....\$99.
Photoshop 4.0 (full version).....\$399.
Photoshop 4.0 (upgrade).....\$139.
Illustrator 7.0 (full version).....\$299.
Illustrator 7.0 (upgrade).....\$109.
FrameMaker 5 (full version).....\$479.
Streamline 4.0 (full version).....\$129.

FREE HAND GRAPHIC STUDIO 7 Upgrade

Full version \$249 **\$189.**

Fractal Design
Detailer (Paints 3D models).....\$289.
Expression 1.0 (object-oriented drawing).....\$289.
Painter 5.0 (full version).....\$259.
Painter 5.0 (upgrade).....\$89.
Poser2.0 (human-models in 3D enviro).....\$129.

ImageXpress
ScanPrepPro 3.1 (automates image-process).....\$639.

Macromedia
Director 6 multimedia studio (full version).....\$899.
Director 6 multimedia studio (upgrade).....\$459.
Director 6 (upgrade).....\$369.
Free Hand V7.0 (full version).....\$199.
Free Hand V7.0 (upgrade).....\$135.
SoundEdit 16.2 (full version).....\$269.

NewTek
LightWave 3D (Pro-Level animation).....\$1399.

Quark
QuarkXpress Passport (multi-language).....\$1,299.
QuarkXpress 4.0 (publishing+Web).....\$689.

Adobe Illustrator 7.0
Upgrade **\$109.**

Strata

Strata Studio Pro 2.1 (3D/animat).....\$899.
Strata Studio Pro 2.1 (upgrade).....\$289.
MediaPaint (profess. painting tool).....\$299.
VideoShop (drag and drop clip making).....\$199.
Vision 3D (integ. 3D soft. pack).....\$209.

Quark Xpress 4.0

Best price on the market **Only \$689.**

Database/Utilities

Claris
FileMaker Pro 4.0 (FullVersion).....\$189.
FileMaker Pro 4.0 (upgrade).....\$95.
Claris Home Page.....\$94.
Claris Works Office.....\$94.
Claris E-Mailer 2.0 (e-mail manager).....\$39.

Symantec
Symantec Visual café.....\$194.
Symantec Visual Page.....\$94.

Caere
Omni Page Pro 7 (OCR soft. pack).....\$439.

Connectix
Speed doubler 2.0.1. (file transfer utility).....\$89.
RAM doubler 2.0.1. (Doubles your RAM).....\$89.

Datawatch
Virex 5.7 (great features in virus-detection).....\$67.

Symantec
SAM 4.5 (virus protection).....\$49.

Effects/Plug-ins/Media

After Effects 3.1

Broadcast multimedia and Film production Tool!

\$389.



Adobe
After Effects 3.1 (full version).....\$389.
Premiere 4.2 (full version).....\$379.
Persuasion 4.0 (full version).....\$299.

Artel Software
Boris Effects 3.0 (Adobe plug-in).....\$439.

DigiEffects
Aurorix 2.0 (full version).....\$249.
Berserk 1.3 (full version).....\$249.

Cyclonist 1.0 (particle-generation soft.).....\$429.
CyneLook (makes your video look like film).....\$599.

Knoll soft.
Lens Flare Pack 1.5 (after effects plug-in).....\$139.

MetaTools
Bryce 3D.....\$164.

Final Effects AP 1.0 (particle-generation).....\$189.
KPT Final Effects 3.0.1 (effects collection).....\$659.

Studio Effects 1.0 (3D particle-generator).....\$659.

M.M.M. Soft.
HoloDoubt 1.0 (Adobe Premiere plug-in).....\$129.

Terran int.
Media Cleaner Pro 2.0.1 (movie comp. tool).....\$279.

The Valis Group
Movie Flow 2.0.2. (image distortion soft.).....\$629.

Scanner UMAX Powerlook 2000



Also: **\$2,299**

Powerlook III (720X486).....\$3,299.00

Scanner AGFA DUOSCAN



Bundled w/ ColorTune full CD version and FotoLook 3.0

Optical Res. of 2000(v)x2000(h)ppi
4000 ppi interpolated
36 bit color / Scan speed 17sec.

Also: ARCUS II w/ TRANSPARENCY.....\$1,199.00

Scanner EPSON 836-XL



B Size **12"X17"**
*36-bit color/12-bit grayscale/Color CCD
*3.3 dynamic range/full tonal range
*Only 10sec.for 12"X17" preview **\$2,299**
836XL TRANSPARENCY ADAPT.....\$499.00

Epson Stylus 3000



Up to 17"x22"
The Ultimate Full Bleed, High Performance Color Comping Device **\$1,699**

Also: HP Color Laser Jet 5M.....\$4,799.00

Film Scanner Nikon CoolScan



LS 1000 35mm film scanner
*Fast 40-second scan times for 2,592 x 3,888 pixels

ensures consistently sharp scans *Special optics preserve definition and overcome problems of geometric distortion *Optional automatic slide feeder for high-speed archiving
AutoFeeder not included **\$1,699**

Printer ELITE XL1208



Supersize for Graphics and Pre-Press
picture of XL1208s model
12x21 **\$3,399**
ELITE XL 1208S PLATEMAKER.....\$4,299.00
ELITE XL 608.....\$1,999.00

CD-R LACIE 2X/6X



\$389
*For large file transfers, media, (sound image) or mass distribution of CD-R provides the least expensive solution! Comes w/ Toast Pro software.

4x/6x CDR.....\$549.00
2X/6XCD-REWRITABLE.....\$659.00

Removable IOMEGA JAZZ DRIVE



2GB Jaz Drive
Fast and reliable
Portable & compact
An ideal solution for multimedia
Backup answer to large systems
Also: 2GB cartridge.....\$129

Video Editing radius EDIT DV



*100% non-linear editing
*Compositing
*Animation
*Special Efx
*All in One Digital Video production solution
*Comes w/ MotoDV™ capture soft.
*NTSC &Quick Time compliant. FOR ONLY... **\$759**

Digital Camera Polaroid PDC2000/40



Featuring a "megapixel" sensor based on Polaroid's in ing science technology, the sleek PDC2000 captures sh vibrant, 241 color digital images that easily transferred to any computer or printed at a resolution level as high as 1600 x 1200 pixels. **\$1,499**

Also: PDC-2000/60.....\$1,799
Hitachi MPEG-(camera only).....\$1,999

TRUEVISION TARGA 2000



Also: **\$2,599**
Targa 2000 Pro (720X486).....\$3,399.00
Targa 1000 (640X480).....\$1,499.00
Targa 1000 Pro (720X486).....\$1,999.00

Digital Camera Olympus D-600L



*1.4 Mega Pixel High-Quality Images & 3XZoom
Lens *Progressive Scan Sensor Captures Images in One Pass for Superb Image Quality *1280 x 1024 and 640 x 512 pixel resolution
3x Zoom, all glass, aspherical
F2.8 autofocus lens
*4 MB SmartMedia™ Removable Media
*Progressive Scan CCD w/ 1.4 Mega Pixel (gross) Back Panel LCD for reviewing images 3 levels of compression *Serial port for connecting to computers and a high-speed parallel port to the Olympus P-300 printer * Auto Flash with "red-eye" reduction.
Adobe PhotoDeluxe incl. **\$1,199**
Olympus D-600L.....

COMPU.D 1-800-929-9333
International, Inc. www.compu-d.com

PowerMacs

7300/180DOS \$1645
32-2GB, 12xCD, Win 95

G3/233	32-4GB, 24xCD	\$1695
G3/266	Desktop 32-4GB, 24xCD, Zip	\$2075
G3/266	Tower 32-6GB, 24xCD, Zip	\$2495
9600/350	64-4GB, 24xCD	\$2975
9600/300	64-4GB, 24xCD, Zip	\$2595
9600/233	32-4GB, 12xCD	\$1995
8600/300	32-4GB, 24xCD, Zip	\$2095
7300/200	32-2GB, 12xCD	\$1395
4400/200DOS	32-2GB, 12xCD	\$1345
Apple DOS Card /all system!		\$395

3400c/200 MHz	16/2GB, CD	\$2445
2400c/180 MHz	16/1.3GB	\$1745
1400c/166 MHz	16/2GB, CD	\$1895
1400cs/166 MHz	16/1.3GB, CD	\$1645

Best Deals on all Memory

Sales: (818) 787-3282 **Fax: (818) 787-5555**
Visit our Web Site for Additional Product Information & Current Price List. e-mail: csales@compu-d.com
6741 Van Nuys Blvd., Van Nuys, CA 91405

PowerBooks

G3/250 MHz	32-5GB, 20xCD	\$3895
3400c/240	48-3GB, CD, 10B-T, 56K	\$3145
3400c/200	48-2GB, CD, 10B-T, 56K	\$2685
1400c/166	32-2GB, 8xCD, 33.6	\$1995
Duo2300c	8-750 & 40-2.1GB	\$995/1395

Printers & Displays

LaserWriter 16/600 PS	\$1095
12/640 PS 12ppm, 600 DPI	\$995
Apple 1705/5100 17" Display	\$485/685
Apple Vision 850/850AV	\$1395/1695

Deals of the Month

5M/5MP	\$1375/595
4MV	\$2295
4000N/TN	\$Best
Adobe Photoshop 4	\$399
PageMaker 6.5	\$359
Illustrator 7.0	\$279
QuarkXpress 4.0	\$699
MS Office 98 MAC	\$Call
UMAX Astra 1200	\$239
LaCie 2x6 CDR/Toast	\$369
LaCie 4x8 CDR/Toast	\$489

All prices are based on C.O.D. order & subject to change!

HAWKE BUSINESS SYSTEMS
A Division of the CPS Services Group
Flemington, NJ 08822

(800) 875-2610 Fax - (908) 782-7027
Email - MacHawke@AOL.COM

We Buy, Sell, Trade, and Repair Macintosh Computer Equipment

Visit Our Web Site - www.MacHawke.com - for Full Listing

Systems	Service Parts	Peripherals
Classic 4/40 w/ K&M - \$149.00	1.4 Meg Floppy Drive - \$79.00	ImageWriter II - \$129.00
Classic II 4/80 w/ K&M \$299.00	Mac II, IIx, IIcx P/S - \$39.00	LaserWriter II Nt - \$325.00
Se/30 8/80 w/ K&M - \$325.00	Mac Classic P/S - \$59.00	LaserWriter IIG - \$499.00
Custom Color Packages	Apple 8 bit Video Brd - \$59.00	
Mac IISI	EtherNet - Nubus RJ45 - \$39.00	Apple 12" Mono - \$75.00
Mac IICi	Mac IISI Nubus Adpt - \$49.00	Apple Portrait Mon - \$199.00
Lc III	Mac Irma Brds - \$55.00	Radius Color Pivot - \$299.00
Centris 610	Logic Board	Apple Hi Res Color - \$225.00
Quadra 650	Exchange & Repair	Apple 15" MultiScan \$299.00
PM 6100	6 Month Parts and Labor	Apple 17" Multiscan \$499.00
PM 7100	System Warranty	Apple 21" Color Mon - \$999.00
PM 7200		

All Color Packages include Apple Color Monitor, ExtKyb & Mouse

DIMMS
16MB 32MB 64MB 128MB
\$42 \$72 \$169 \$239

SIMMS
8MB 16MB 32MB 64MB
\$19 \$39 \$69 \$205

G3-RAM
32MB 64MB 128MB
\$79 \$199 \$429

G3-VRAM
4MB 8MB
\$49 \$79

LIFETIME WARRANTY

US MAC & PC
17481 Mt. Cuffwood Circle Fountain Valley, CA 92706

Quantum Drives

EXT.	IDE	INT.
2.1GB	Stratus, 5400 10ms	*224 *274 *169
2.1GBuw	Atlas2, 7200 8ms	*259 *339
3.2GB	Stratus, 5400 10ms	*269 *319 *194
4.3GB	Stratus, 5400 10ms	*294 *344 *224
4.5GB	Atlas2, 7200 8ms	*494 *544
6.4GB	Stratus, 5400 10ms	*394 *444 *294
9.1GB	Atlas2, 7200 8ms	*774 *824

CALL FOR POWERBOOK MEMORY! ALSO LASER & LAPTOP MEMORY. PLUS MORE.

888-699-7199

Mac OS System 8.x Complete Upgrade \$49.99
or MacOS 7.6 for \$19

Power 120 0/0/0 (U) \$399
16/800/12x \$599
Includes Keyboard & Mouse
PowerBase 240Mhz Upgrade \$99.00

PowerMAC 6100-60 16/240 \$499
Includes Keyboard & Mouse
w/ Apple 14" AV Trinitron \$699
6100 A/V Upgrade Kit (N) 99.00

Mac SE 4/120 w/Key & Mouse (U) 99.00
Mac LC II 4/80 w/Key & Mouse (U) 129.00
Mac II 8/160 w/Key & Mouse (U) 199.00
Q610 8/240 w/Key & Mouse (U) 249.00
PMac 7100 16/500 w/Key & Mouse (U) 599.00

Performa 6360 (R) \$789
603c 160 Mhz 16/1.2GB/8xCD

12X CDROM SCSI \$89
Bootable
*External \$119

28.8 bps modem \$49
External *NEW*
*Includes Cables

20" Apple Two Page Mtr (U) 99.00
20" Color Monitors (U) from 449.00
17" Color Monitors (U) from 249.00
Apple 15" AV MultiScan Mtr (N) 339.00
Apple 15" AV MultiScan Mtr (U) 279.00
Apple 15" MultiScan Mtr (U) 229.00
Apple 14" Color Plus Mtr (U) 199.00
Apple 13" RGB Trinitron Mtr (U) 179.00
ADB Mouse, Single Button, Mac (N) 16.50
Apple StyleWriter II B/W (U) 89.00
Epson Stylus 600, 1440 dpi Color (N) 259.00
Epson Stylus 800, 1440 dpi Color (N) 369.00
Apple LaserWriter II nt w/Toner (U) 199.00
Apple Personal LaserWriter LS (U) 129.00

Hewlett-Packard 5MP (R) \$499
6ppm, 600dpi includes Toner

800-673-6227 BUY/SELL LEASE

PowerON computer services • 4323 Anthony Ct. #1 • Rocklin, CA 95677
www.poweron.net

Prices subject to change without notice. All Prices include 3% cash discount. (916) 652-1880 • (916) 652-1881 FAX Mon.-Sat. 10a-5p PST All Sales Final. All Products Receive Minimum 90 day warranty

1-800-334-KIWI

Kiwi Computers • Save on refurbished Macs

Mac Computers

Performa 630 8/350 2xCD	\$335
Performa 630 12/1 Gig 4xCD	\$399
Performa 6200/75 8/1 Gig 4xCD	\$549
Performa 6300/100 16/1.2 Gig 4xCD 28.8	\$699
Performa 6400/200 16/2.4 Gig 8xCD 28.8	\$999
PowerMac 5400/180 & 5400/200	Call
PowerMac 7200/120 16/1.2 Gig 4xCD	\$935
PowerMac 7600/120 16/1.2 Gig 4xCD	\$1149
Powerbook 5300cs 8/750	\$975
Powerbook 5300c 16/1.1 Gig	\$1349

Upgrades

Logic board upgrade prices are with exchange.

PowerMac 7200 to 7600	\$499
Performa 630 series to 6300/100mhz	\$425
Performa 630 series to 6320/120mhz	\$499
Performa 6200 to 6360/160mhz	\$499
Performa 6300 to 6360/160mhz	\$425
Performa 600/IIvx to Quadra 650	\$235
Performa 600/IIvx to PowerMac 7100/80	\$499
Quadra 650 to PowerMac 7100/80	\$449
Quadra 610 to PowerMac 6100/60	\$499
Quadra 660AV to PowerMac 6100/60	\$399
Mac LC III to Quadra 605	\$235
Math Coprocessor for P575 & P630	\$88

Monthly Specials

Apple Design Keyboard	\$25
Apple PlainTalk Microphone	\$10
Apple manual inject 1.44 floppy	\$49
Apple auto inject 1.44 floppy	\$69
Performa 630 6200 6300 power supply	\$45
1.2 Gig IDE internal hard drive for Performa	\$119
GV Platinum internal 28.8 Modem for P5200/6200	\$59

Memory

16mb 72 pin SIMM	\$30
32mb 72 pin SIMM	\$65
32mb 168 pin DIMM	\$75
64mb 168 pin DIMM	\$145

Visa/Mastercard/American Express No Surcharge.

Rel refurbished products have a 90 day warranty • Returns subject to a 15% restocking fee • Prices subject to change without notice.

Toll Free: 800-334-5494 International: 310-553-4507 Fax: 310-286-9667
Hours: Mon-Fri 8am to 6pm, Sat 9am to 2pm • Better Business Bureau Member
Kiwi Computers, P.O. Box 67381, Los Angeles, CA 90067

CALL THE MAC EXPERTS!

Your one-stop source for everything Macintosh. Complete solutions and expert advice our specialty!

Us

- Our salespeople are some of the most knowledgeable in the business. They're not order takers and they don't push for a one time sale. After all, over half our business comes from repeat and referred customers!
- We load over 160 megabytes of useful software on every computer.
- Every Mac system is thoroughly bench tested, and then personally verified and approved by your specific consultant.
- We have 800 line tech support for as long as you own your computer.
- We will customize your computer any way you need, and always with an exact description as to what we're including.
- We give you a free mouse pad with every system.
- We have no voice mail—there's always a human being on the other end of the line—for tech, sales and management.
- We answer the phone: "how can we help you?" not "may I take your order?"
- We live in Oregon, where there is no sales tax and the people are friendly and polite!
- Even customized systems usually ship within 24-48 hours.
- We have competitive prices on over 18,000 Macintosh items.
- We usually approve government and corporate purchase orders the same day.
- We take trade-ins, and we sell every type of quality Macintosh possible.
- All we do is Macintosh—our company is run entirely on Macs.

Them

- They sell you a box.
- If you have a problem, they tell you to call the manufacturer. And then you get to wait on hold for a long, long time.

You

- Potentially one of the most important people in the world: our customer.

Package 52W984

Factory Refurbished Performa 5200 w/16 Mb RAM, 500 Mb hard drive, built-in color display, video in, Mac CD bundle with Atlas, games, dictionaries & many more. Only **\$849**, or just **\$35 per month!***



Extra CDs!

*Only while supplies last!

Package 73W984

PowerMac 7300/180 with Pentium Board! 32 Mb of Mac RAM, 16 Mb of Pentium RAM, 2 Gig hard drive, 12x CD Rom, 15" Color Monitor, Windows 95, Dabber 2 Mac/Win CD. All this for only **\$1999**, or just **\$80 per month!***



Dabber!

Pictures may not match monitor in package

Package 62W984

Factory Refurbished Performa 6230 w/16 Mb RAM, 1 gig drive, 15" color display, Apple Color StyleWriter 2500, 97 Groliers encyclopedia. Only **\$1199**, or just **\$48 per month!***



Groliers!

Package G3W984

Macintosh G3 233 desktop, 64 mb RAM, 15" Color Display, Quickbooks 3.0 software, deluxe APC surge protector. Only **\$2299**, or just **\$96 per month!**



Quickbooks!

Package 96W984

PowerMac 9600: 300 MHz with 96 Mb RAM, 4 gig drive, 24x CD, 17" color display, internal 1 Gb Jaz drive, Macromedia Director 5.0. Only **\$5299**, or just **\$190 per month!**



Director!

Package G6W984

PowerMac G3 Tower: 266 MHz w/96 Mb RAM, 6 gig drive, 24x CD, internal Zip drive, 17" color display, Microsoft Office 4.2.1 CD, deluxe APC surge protector. Only **\$3799**, or just **\$149 per month!**



MS Office!

newer technology Upgrade your current Mac to G3 speed!

For most PowerMacs w/PCI, PowerComputing & Umax: **NEW!** For PowerMac 6100s, 7100s and 8100s:
 MaxPowr G3 275MHz w/1 Mb Cache/275\$1799
 MaxPowr G3 275MHz w/1 Mb Cache/183\$1349
 MaxPowr G3 266MHz w/512 Cache/133\$1049
 MaxPowr G3 250MHz w/512 Cache/125\$899
 MaxPowr G3 for 6100 210MHz w/512 cache...\$498
 MaxPowr G3 for 6100 210MHz w/1 Mb ca.....\$678
 MaxPowr G3 for 71/81 210MHz w/512 ca\$588
 MaxPowr G3 for 71/81 240MHz w/1 mb ca.....\$788

PowerMax Hard Drives

The best drives money can buy! Call for a quote on our super-fast custom arrays!

9 Gig for \$699!*

- 12X External CD Rom.....\$139
- 24X External CD Rom.....\$159
- Ref Ext Jaz One Gig Remble ..\$288
- Ext Jaz One Gig Remble ..\$349
- 4x6 CD Recorder w/Toast ..\$569
- Ext 2 Gig 5400 RPM 3 yr Warr ..\$259
- Ext 4.3 Gig 7200 RPM 5 yr Warr \$349
- Ext 6 Gig 5400 RPM 3 yr Warr ..\$439
- Ext 9 Gig 7200 RPM 1 yr Warr* ..\$699

Trade Up with PowerMax!

Turn your old equipment into the latest Mac system!

We will take your hard drive (dead or alive— 540 Mb or larger) or Macintosh computer in trade toward the purchase of any product we sell! Call one of our expert system designers for complete details!

Call for the **absolute lowest prices** and immediate delivery on over **18,000 Mac products!**

We can build you a complete system for under \$800!

PowerMax Trinitron™ Monitors

- Model PM15T 25 mm dot pitch-up to 1280x1024\$349
- Model PM17T 25 mm dot pitch-up to 1280x1024\$649
- Model PM17TE+ 25 mm dot pitch-up to 1600x1280\$849
- Model PM20T 30 mm dot pitch-up to 1600x1280\$1449
- Model PM20T+ 25 mm dot pitch!.....\$1649



COMPARE & SAVE!

PowerMax Trinitron™ monitors are designed specifically for the rigorous demands of the Macintosh. They ship complete with Mac-ready cables and adapters, a three year warranty, and our satisfaction guarantee: if the monitor is not just right, we'll replace it for you!

MacUser Labs Reviews: "Four Mice! A Power-Max Power Play" and "Not only do the PowerMax monitors display good-looking images, but (they) are affordably priced!" and "Nice price, nice image quality, nice controls — nice monitor!"

Customizable Mac Systems

- PowerMac 7300/180 16 Ram/12x/KB\$1219
- PowerMac 7300/200 16 Ram/12x/KB\$1419
- PowerMac G3 233 32/24x CD/KB\$1769
- PowerMac G3 266 32/24x CD/Zip/KB\$2119
- PowerMac G3 Twr 266 32/24x/Zip/KB\$2619
- PowerMac 8600/200 32 Ram/24x CD\$1599
- PowerMac 8600/250 32 Ram/24x CD\$1849
- PowerMac 8600/300 32 Ram/24x CD\$2049
- PowerMac 9600/200 MP 32 Ram/12x CD \$Special!
- PowerMac 9600/300 64 Ram/24x CD\$2599
- PowerMac 9600/350 64 Ram/24x CD ..\$Price drop!
- Ready-Made Mac Systems
- PowerMac 4400/200 16/1 Gig/8x.....\$Call!
- PowerMac 4400/200 PC Compatible.....\$1299
- PowerMac 6400/180 16/1.6/CD\$999
- PowerMac 6400/200 16/1.6 w/ethernet!.....\$1199
- PowerMac 5400/180 32/1.6 All-in-one.....\$1299
- PowerMac 6500 Series Price Drop! Call for the absolute latest lowest prices around!
- PowerMac 7300/180 Pentium System\$1699

- PowerMac G3 233 32/4000/24x CD/KB\$1869
- PowerMac G3 266 32/4000/24x CD/Zip/KB.....\$2215
- PowerMac G3 Twr 266 32/6000/24x/Zip/KB ..\$2795
- Powerbooks- Your complete source!
- Powerbook 5300CS/100 8/750\$999
- Powerbook 1400CS/166 16/1.3/CD\$1888
- Powerbook 1400C/133 16/1.3/CD\$1948
- Powerbook 1400C/166 16/2 Gb/CD\$2088
- Powerbook 2400C/180 16/1.3/CD\$2288
- Powerbook 3400 series price drop!\$Call!
- Powerbook G3 250 32/5 Gb/20x/Modem/Eth ..\$5149
- PowerComputing Closeouts
- PowerBase 180 16/2 Gb/16x CD\$849
- PowerBase 200 16/2 Gb/12x CD\$1049
- PowerBase 240 16/2 Gb/12x CD\$1149
- Umax SuperMac- we stock all models
- SuperMac C500/240E 24/3.3/24x\$1395
- SuperMac C600/240LT 24/2/12x.....\$1395
- SuperMac C600/280 32/4 Gig/12x\$1795
- SuperMac S900i/250 64/4 Gig/24x\$2995

POWER MAX

Knowledge is Power

800-613-2072

Local line: (503) 624-1827 • Fax (503) 624-1635
<http://www.powermax.com> • email: powermax@europa.com

Prices subject to change without notice. Prices reflect cash discount. Credit card orders strictly verified against fraudulent use. With use of credit card as payment customer acknowledges that some products are subject to final sale.

We accept educational and corporate purchase orders, and are experts in financing for virtually any size business!



FAST CASH

www.mactraders.com

For ALL Macs, Memory & Peripherals — Working or not

TOP DOLLAR PAID

Mac Traders (800)990-0995

(310) 576-2466 Mon.-Fri. 9 AM-6 PM Sat. 10 AM-4 PM (P.S.T.) Fax: (310) 394-7323
1511 Lincoln Blvd. (bet. Broadway & Colorado), Santa Monica CA, 90401

PACIFIC COMPUTER EXCHANGE

Used Macs Priced to Move

800.790.3881

We buy and sell used Macs!

Cash paid for your Mac via Fed Ex!

SPECIAL!

Media Vision Refurbished 2X External CD ROM \$69

NEW!! 14.4 Internal Modem for Powerbook 100 Series \$49

6360/160 32/1 Gig CD.....\$799	Color Classic.....\$399	6220/75 16/1 Gig CD/refurb.....\$849	PB 540c 8/320 19.2 modem.....\$1199
7100/66 8/250 CD.....\$699	Powerbook 520 / 520c.....\$899 / \$999	6116/66 8/700 CD.....\$699	Powerbook 180 / 180c.....\$799 / \$899
Quadra 840AV.....\$599	Powerbook 160/170.....\$599	Quadra 650/660AV.....\$499	Powerbook 145/150.....\$499
Quadra 700.....\$399	LaserWriter Int./ntx./llg.....\$299 / \$399 / \$599	Quadra 610/630.....\$429 / \$469	HP DeskWriter.....\$129
lilc/llvx.....\$229	Apple StyleWriter 2400.....\$169	lilsi/lllxc.....\$199	ImageWriter II.....\$129
LC/LCII/LCIII.....\$199 / \$229 / \$249	Apple 17" MSColor Monitor.....\$499	SE/SE30.....\$149 / \$299	SuperMatch 20" Color Monitor.....\$299
Classic/ClassicII.....\$199 / \$299	NEWMultiMedia 180WSpeakers.....\$39		

Infinity Micro

One stop shopping for all your software & hardware needs!

800 • 589 • 1234

TEL 310 • 470 • 9426 FAX 310 • 470 • 4956

"We Match, We beat, We deal." CALL US LAST!!

POWERMAC

G3/233 32/4GB/24XCD/56K \$1995.

G3/266 128/4GB/24XCD/Vid \$3895.

G3/233MHz 32/4GB/24XCD \$1775.

G3/266MHz 32/4GB/CD/ZIP \$2045.

G3/266MHz 32/6GB/CD/ZIP \$2695.

4400/200 16/2GB/CD/KB \$1295.

4400/200 32/2GB/CD/DF/KB \$1485.

4400/200 32/2GB/CD/PENT \$1795.

6500/225 32/3GB/CD/3F/KB \$1295.

6500/250 32/4GB/CD/ZIP/KB \$1445.

6500/250 48/4GB/CD/3F/MS \$1695.

6500/275 48/4GB/AVID \$1695.

6500/300 64/4GB/12XCD \$2145.

7100/80 8/700 CD \$795.*

7200/90 8/500/4XCD \$795.*

7200/120 16/1GB/4XCD \$995.*

7200/120 8/1.2/4CD/PENT. \$1295.

7300/180 16/2GB/CD/KB \$1299.

7300/180 16/2GB/CD/DOS \$1695.

7300/200 32/2GB/CD/KB \$1495.

7500/100 16/1GB/4XCD \$995.

8100/100/110 or 7600 ser. call

8500/150 32/2GB/8XCD \$1449.

8600/200 32/2GB/CD/zip/kb call

8600/230 32/4GB/CD/ZIP/KB \$2045.

8600/300 32/4gb/12xCD/z/k \$2295.

9500/180MP 32/2GB/8XCD \$2295.

9600/200 32/4GB/CD/KB \$2195.

9600/200MP 32/4GB/CD/KB \$2595.

9600/233 32/4GB/12XCD \$2395.

9600/300 64/4GB/16xCD/Zip \$2795.

9600/350 64/4GB/24xCD/Zip \$4495.

PERFORMA

5200/75 8/800/CD \$895.

5215/75 8/1GB/CD/14.4 \$949.

5260/100 16/800/CD \$1095.

5300 /120 16/1GB \$1095.

5400/180 16/1.2/CD \$1295.

6400DS 12/500/CD \$695.

6116 8/500/CD \$595.

6200/75 8/1GB/CD \$595.

6220TV 16/1.2GB/CD \$745.

6300/100 16/1.2/CD \$745.

6320CD 16/1GB/CD \$795.

6360/160 16/1.2/CD \$795.

6400/180 32/2GB/CD \$995.

6400/200 16/2.4/CD \$1049.

6400/200VE 16/2.4/CD \$1195.

POWERBOOK

G3/250MHz 32/5GB/20XCD/33.6 \$5195.

G3/250MHz 32/5GB/20XCD \$4595.

3400C/240MHz 16/3GB/CD \$3195.

3400C/240MHz 16/3GB/CD/56 \$3595.

3400C 200MHz 16/2GB/12xCD \$2695.

3400C 200MHz 16/2GB/CD/mdm \$2895.

3400C/180MHz 16/1.3GB/12CD call

3400C/180MHz 16/1.3GB/6xCD call

1400C/166 16/2GB/8XCD \$1895.

1400C/133 16/1GB/CD \$1695.

1400C/117 32/1 GIG/CD \$1595.

1400CS/166 16/2GB/8XCD \$1729.

1400CS/133 16/2.1GB/CD call

5300CE/117 32/1GIG call

5300C 16/1GB call

5300CS 16/750 \$1095.

2300C 20/1GIG/14.4 \$1095.

2400C /180 16/1.3GIG call

540C 16/500/14.4 Tech yr \$1895.

520 8/250/MODEM 150 8/240 Revtable \$1895.

180 14/120/14.4 fax Mail \$695.

MONITORS

Radius PrecisionView 21" \$1695.

Radius PressView 17SR \$1595.

Radius PressView 21SR \$2895.

RasterOps MC20 20".28 \$1345.

RasterOps MC-801 21" \$1595.

RasterOps MC-801HR \$1695.

RasterOps M7515 19" \$1095.

SuperMac 21" Color \$895.

Sony 100ES/100GS \$349./\$379.

Sony 200ES/200GS \$629./\$689.

Sony 200PS/400PS \$845./1195.

Sony 300SF/500PS \$call/1145.

ViewSonic 17GA/17PS \$589./\$595.

ViewSonic EA771/G771 \$579./\$495.

ViewSonic GT770/P775 \$629./\$595.

ViewSonic G790 19" \$795.

ViewSonic G810 21" \$1045.

ViewSonic P810 21" \$1175.

ViewSonic P815 21" \$1245.

ViewSonic PT810 21" \$1245.

ViewSonic PT813 21" \$1295.

PRINTERS

StyleWriter II \$179.

StyleWriter 1200/1500 \$99./129.

StyleWriter 2200 \$389.

StyleWriter 4100 Color \$239.

StyleWriter 4500 Color \$339.

StyleWriter 6500 Color \$469.

LaserWriter 4/600 \$695.

LaserWriter 12/640 \$995.

LaserWriter 12/600 \$1389.

LaserWriter 8500 \$2395.

LaserWriter Color 12/660New \$3495.

LaserWriter Color 12/660Demo \$2995.

LaserWriter Color 12/600Demo \$1895.

Epson Stylus 600 \$279.

Epson Stylus 800 \$419.

Epson Stylus 1520 \$795.

Epson Stylus 3000 Color \$1679.

Fargo Pictura 310 \$2395.

Fargo Pictura 310Ethernet \$2295.

Fargo PostScript option \$295.

Gcc Elite XL-1212 Laser \$1089.

Gcc Elite XL-616 \$1845.

Gcc Elite XL-608 \$2129.

Gcc Elite XL-808 \$2485.

Gcc Elite XL-1208 PlateMaker \$4095.

HP Deskjet 870CXI \$389.

HP Deskjet 1600CM \$1585.

HP LaserJet 5MP \$645.

HP LaserJet 6MP \$875.

HP LaserJet 4M \$2195.

HP Laser 5M \$389.

HP Laser 5SIXM \$3395.

SCANNERS

AGFA SNAPSCAN 310 \$195.

SNAPSCAN 600/600ART \$385.

AGFA StudioStar \$785.

AGFA Arcus II w. transparanci \$1445.

AGFA DuoScan CALL.

Epson Exp. 636 Executive \$735.

Epson Exp. 636 Artist 600dpi \$895.

Epson Exp. 636 Professional \$1285.

Microtek ScanMaker E3 \$199.

Microtek ScanMaker E6 ST \$479.

Microtek ScanMaker E6 Pro \$585.

Microtek ScanMaker III \$1175.

Microtek ScanMaker 35T Plus \$729.

Microtek ScanMaker Internet \$549.

Umax Astra 610S 300dpi \$159.

Umax Astra 1200S 600dpi, P.D. \$375.

Umax Astra 1200S 600dpi, Pshop \$445.

Umax PowerLook II/2000 \$1195.

Umax PowerLook III \$3395.

SERVERS

7250/120 12/1GB/Internet \$1095.

7350/180 48/4GB/12xCD \$2375.

7350/180 48/4GB/CD/Internet \$2795.

7350/180 48/4GB/CD/A.Share \$3895.

9650/233 64/4GB/CD/Internet \$4695.

9650/233 64/2x4GB/CD \$5645.

9650/233 64/2x4GB/CD/A.S. \$5645.

9650/233 64/4GB/AS/DAT \$5645.

9650/350 64/4GB/CD/A.S. \$CALL

500/132 32/CD/Base System \$6295.

500/132 32/2GB/DAT/CD \$7895.

700/150 32/1GB/CD \$7495.

700/150 48/4GB/DAT/CD \$9295.

700/200 48/2x4GB/CD \$10695.

NEWS/SHORTBEST

Optquest Q41 14" \$195.

Optquest Q53 15" \$289.

Optquest Q71 17" \$475.

Optquest V641 14" \$229.

Optquest V773 17" \$485.

Optquest V775 17" \$525.

Optquest V95 19" \$795.

ZIP/JAZZ/IB'S

Iomega Zip/Zip Plus \$149./199.

Iomega Buzz "New" \$199.

Iomega Jazz 1GIG \$379.

Iomega Jazz 2GIG \$635.

EZ-QUEST Jazz 1GB w.1 cart. \$339.

MEMORY PRODUCTS

PowerMac 16MB Dimms \$69.

PowerMac 32MB Dimms \$89.

PowerMac 64MB Dimms \$175.

PowerBook 16MB 3400 \$95.

PowerBook 32MB 3400 \$149.

PowerBook 64MB 3400 \$249.

GT memory products in stock call.

SOFTWARE

Adobe Photoshop \$345.

Adobe Illustrator \$279.

Adobe PageMaker \$279.

Adobe After Effects \$1245.

Quark Express package \$649.

Microsoft Office package \$295.

Electric Image Broadcast \$2295.

Lightwave 3D \$1095.

PHASER

PHASER 140 \$949.

PHASER 300X \$4945.

PHASER 305 LASER \$2945.

PHASER 380 COLOR \$7845.

PHASER 450 COLOR \$6045.

PHASER 480X COLOR \$14445.

PHASER 550 LASER \$3945.

PHASER 600WIDE \$11989.

PAINTJOB

SprintScan 35LE \$719.

SprintScan 35ES \$1375.

SprintScan 35Plus \$1675.

SprintScan 45 \$8095.

Apple Color Laser 12/660 Printer

\$2499.

\$4999.

\$1895.

Demo unit 127500

Includes: v New toner kit v240HD v28MB Memory

HP LASER 5MP 600DPI, POSTSCRIPT LVL2

\$599.

To order product please call:

TEL: **800-589-1234**

GE 3 YEAR ON-SITE WARRANTY

"Over 2700 products to choose from!"

\$135.95	\$165.95	\$189.95	\$219.95	\$249.95
----------	----------	----------	----------	----------

158 April 1998 MACWORLD

CIRCLE 455 ON READER SERVICE CARD



Macintosh Systems & Peripherals

Guaranteed Low Prices • Huge Inventory

Pricing, Product Spec's and Specials at www.digicore.com



*** SOFTWARE ***

- Full Retail Versions • Not Upgrades
- Adobe Pagemaker 6.5 329
- Adobe Illustrator 7.0 329
- Adobe PhotoShop 4.0 369
- Microsoft Office 4.21 299
- MacroMedia Freehand 7.0 299

POWERBOOKS POWERMACS



- Targus Carry Case \$39
- Leather Carry Case \$65
- 33.6 Fax Modem Pcmci \$139
- 10BT Ethernet Pcmci \$99
- 56k Fax Modem Pcmci \$265
- 56k Modem/Ether Pcmci \$345



We Will
Custom Configure
Any System to Your
Specifications
and ship it with in 24 Hours

G3 PowerMacs

- G3/233, DT 32-4G - 24xCD 1719
- G3/266, DT 32-4G - 24x - Zip 2065
- G3/266 AV, MT 32-6G - 24x - Zip 2565

PowerMacs

- 6500/225, 32-3 GB -12x-33.6 1285
- 6500/250, 32-4 GB -24x- 56k-Zip 1645
- 6500/275, 32-6-24xCD-56k-Zip 1890
- 6500/275, 48-6-24xCD-56k-Zip 2117
- 6500/300, 64-6-24xCD-56k-Zip 2269
- 7300/180, 16-2GB - 12xCD 1350
- 7300/180, PC Comp 32-2GB-12x 1689
- 7300/200, 32-2GB - 12xCD 1499
- 8600/250, 32-4GB - 24xCD - Zip 1958
- 8600/300, 32-4GB - 24xCD - Zip 2299
- 9600/300, 64-4GB - 24xCD - Zip 2898
- 9600/350, 64-4GB - 24xCD - Zip 4099

Custom Config. Examples

- G3/233, DT 32-4G - 24xCD-56K 1829
- G3/233, DT 32-4G - 24x - Zip 1856
- G3/266, DT 64-4G - 24x - Zip 2140
- G3/266 AV, MT 64-6G - 24x 2565
- G3/266 AV, MT 96-6G - 24x - Zip 2785
- G3/266 AV, MT 32-6G - 24x - Jaz 2815
- 7300/200, 64-2GB - 12xCD-Zip 1715
- 8600/250, 96-4G-24x-8Mvram-Zip 2525
- 8600/300,128-4G-24x-8Mvram-Jaz 3149
- 9600/300, 0-0 2275
- 9600/350,192-9GAV-4x6CDR-Jaz 5769

MEMORY UPGRADES

- TECHWORKS - LIFE TIME WARRANTY
- 16 Meg Dimms & Simms 60ns 69
 - 32 Meg Dimms & Simms 60ns 89
 - 64 Meg Dimms 169
 - 128 Meg for G3 425
 - PB 1400 8 / 16 / 24 75 / 99 / 185
 - PB 1400 32 / 48 Modules 199 / 355
 - PB 2400 16 / 32 Modules 119 / 199
 - PB 3400 16 / 32 / 48 99 / 195 / 315
 - PB 3400 64 / 128 Modules 389 / 735

Call For Unlisted Items
Over 2500 Macintosh
Products Available

Leasing

On Approved Credit to...

Business and Individuals

Small Business Internet Solution



only
\$2399 **\$81**
per mo.

- G3/233 Mhz 32 Megs Ram , 2 Gig HD, 12xCD , Ethernet
- 15" AV Display, Ext., Keyboard & Mouse
- 56.6 k Fax Modem, Netscape Ver. 3.0
- Microsoft Office Ver. 4.2.1,
- Internet Connection Kit, Mac OS 8.0

Home-Work and Fun!!

\$1799 **\$59**
per mo.



- 6500/233 32 Megs Ram, 4G HD, 24xCD
- 15" AV Display, Ext. Keyboard & Mouse
- Epson Stylus 600 Color Printer, 56.6 Fax Modem
- Internet Connection Kit, Claris Works
- Touchbase / Date Book Pro, Encyclopedia
- 3-D Atlas, Dictionary, Mayo Family Health
- Clip Art, 3-D Accelerated Games, and much more!

Graphics Station

G3 Speed Demon w/Adobe Bundle



\$4479 **\$151**
per mo.

- G3/266 AV 64 Megs Ram, 6 Gig HD
- 24xCD Player, ATI 6 MB Accelerated Video
- Iomega Zip Drive , Apple 17" AV Display
- Apple Extended Keyboard & Mouse
- Adobe PhotoShop 4.0, Adobe PageMaker 6.5
- Adobe Illustrator 7.0

Cyber Shop & Product Info at...
www.digicore.com

Storage Products

- Iomega Zip Drive 139
- Iomega Jazz Drive 1GB 375
- Iomega Jazz Drive 2GB 579
- Syquest Syjet 1.5 GB 379
- La Cie 2.1 External 249
- La Cie 4.3 AV External 399
- Seagate Hawk 2 GB 249
- Quantum 4.5 Atlas 649
- Seagate 9 GB Barricuda 799
- La Cie 9GB AV External 899
- LaCie 18GB Raid Array 2950
- Atto Express PCI Wide 359
- JackHammer PCI Wide 379

PRINTERS



- Apple SW 4500 335
- Apple SW 6500 459
- Apple LW 4-600 745
- Apple LW 12-640 1275
- Apple LW 8500 (20 ppm) 2225
- Apple Color LW 12-660 5450
- Epson Color Stylus 600 285
- Epson Color Stylus 800 399
- Epson Color Stylus 1520 739
- Epson Color Stylus 3000 1769
- Epson Color Stylus Pro XL 1389
- Hewlett Packard 870CSI 389
- Hewlett Packard 6MP 885
- Hewlett Packard 5M 1555
- Hewlett Packard 4MV 2495
- Tektronix Phaser 140/350 925/2765
- Tektronix Phaser 550 8099

Video / Graphics

- TwinTurbo - 4 / 8 Meg 299 / 499
- #9 Imagine 128 8 Meg 549
- Xclaim VR - 2 / 4 Meg 199 / 299
- ThunderPower 30/1600 829
- MiroMotion DC20 599
- MiroMotion DC30 675
- Targa 1000 / 2000 1575 / 2985
- Targa 2000 PRO 3375
- VideoVision Studio 2.0 2299

RCD & Optical Drives

- Fujitsu Dynamo 640 489
- FWB Hammer Dat 8000 1199
- Olympus 2.6 Power MO 1699
- Pinnacle Vertex 2.6 995
- Pinnacle Apex 4.6 1425
- VST 230 MB PB1400 425
- Yamaha CD 4X6 w/Toast 699



MONITORS

- Apple • Hitachi • NEC
- Radius • RasterOps • Sony
- Viewsonic • CXTX • Samsung
- Phillips • MAG • Nanao

- Apple 15" AV Display 349
- Apple 17" 1705 / 720 525 / 599
- Apple 17" 750 / 750AV 789 / 875
- Apple 20" 850 / 850AV 1649 / 1775
- Nec 15" M500 379
- Nec 17" M700 745
- Nec 21" P1150 1499
- Radius 17" PressView 17SR 1695
- Radius 21" PressView 21SR 2899
- RasterOps 21" MC801HR 1739
- Sony 15" 100SX / 100SF 310 / 369
- Sony 17" 200GS / 200ES 589 / 635
- Sony 20" 300SFT 1325
- ViewSonic 17" EA / GA 545 / 575
- ViewSonic 17" P775 / PT775 599 / 699
- ViewSonic 21" PB10 / PB15 1275 / 1445

Call Digicore

Order Toll Free

800-858-4622

International & Dealers

818-785-2800

24 Hour Fax

818-785-3100

15500 ERWIN ST, VAN NUYS CA 91411

36 Month Lease w/Purchase Option

\$2500	\$4000	\$8000	\$15,000	\$25,000
\$85	\$136	\$267	\$496	\$825

Sale Price
Your Cost

GE ON-SITE WARRANTY 2nd - 4th Year

\$700 - \$1200	\$1201 - \$2000	\$3001 - \$4000	\$4001 - \$5000
\$129	\$159	\$219	\$249

Lease rates listed are for businesses - call for individual rates • Leasing is O.A.C. • Prices listed are C.O.D. • Pricing & Availability subject to change • Call for best Price • Returns Require DigiCore RMA •

800-689-3933

Service (310) 479-0999
Fax (310) 312-9041

A



Macintosh PowerMac's



4400/200 DOS
• 32MB
• 2GB
• 12x CD
• DOS Card
\$1299

G3 233MHz
• 32MB
• 4GB
• 24x CD
• Desktop
\$1699

G3 266MT 32/6GB/24x/512k	2599
G3 266DT 32/4GB/24x	2049
9600/350 64/4GB/24x/CD	3199
9600/300 64/4GB/24x/CD	2699
9600/233 32/4G/12x/CD	2299
9600/200 32/4G/12x/CD	1999
9600/200 0/0/CD	1399
9600/200MP 32/4G/12x/CD	2499
9500/150* 16/2G/4x/CD	CALL
8600/300 64/4G/24x/CD	2099
8600/300 64/4G/24x/CD/zip	2299
8600/250 32/4GB/24x	1899
8600/200 32/2G/CD	CALL
8500/180* 32/2G/8x/CD	CALL
8500/150* 16/2G/CD	CALL
7600/132* 16/1.2G/CD	CALL
7300/200 32/2G/CD/KBRD.	1499
7300/180 16/2G/12x/CD/KBD.	1599
7300/180 32/2G/8x/DOS Compatible P166	1599
7200/120* 16/1.2G/4x/CD/DOS	999
7200/120* 16/1.2/CD	899
7200/90* 8/500/4x/CD	749
6100/66* 16/500/4x/CD/DOS	849
4400/200 16/2G/8x/CD/DOS	1199
4400/200 32/2GB/12/DOS COMP.	1299
6500/225 32/3G/12x/Modem	1399
6500/250 32/4GB/CD/56K	1599
6500/275 32/4GB/CD/MDM	1799
6500/300 64/4G/CD/Zip	1899

Macintosh Powerbooks



1400c/166
• 16MB
• 2GB
• CD
\$1999

3400c/240
• 16MB
• 3GB
• 12x CD
\$3099

C: Active Color, CS: Passive Color	4299
G3 250MHz 32/5GB/24x	4499
G3 250MHz 32/5GB/24x/MODEM	4999
1400cs 133MHz 16/1.3G/CD	1400cs
1400cs 166MHz 16/1.3G/CD	1699
1400c 133MHz 16/1G/CD	1799
1400c 166MHz 16/2G/CD	2079
3400c 180MHz 16/1.3G/CD	2699
3400c 200MHz 16/2G/CD	2699
3400c 200MHz 16/2G/CD/Modem	2899
3400c 240MHz 16/3G/CD/Modem	3299
2400c 180MHz 16/1.2GB/	1999
5300c 32/1G	499
5300c 16/750	499
520c 8/750	799
5300cs/100* 16/750/14.4 Modem	1199
540c 4/320 Used	999
520c 4/240	999
520 4/240	799
DUO250* 12/200/Modem	999
DUO280* 12/240/Modem	799
DUO280C* 12/240	799

Macintosh Workgroup Servers



9650/350 64/4G/20x/Dat Apple Share	CALL
9650/233 64/4G/12x/Apple Share	CALL
9650/233 48/4G/12x/Internet Ready	CALL
9650/233 48/4G/12x/2GB Dat Drv.	CALL
8550/200 32/2G/CD/Apple Share	CALL
8550/200 32/2G/CD/Apple Share/Dat	CALL
7350/180 48/4G/12x/Apple Share	CALL
7350/180 48/4G/12x/Internet Ready	CALL
7350/180 48/4G/12x	CALL
7250/120 16/1.2G/CD/Networking	CALL

Powerbook Hard Drives
1.4GB Toshiba 1401MAV 12ms 279.
2.1GB Toshiba 2103MAV 12ms 129.
3 GB Hitachi Slim 12ms 339.

omega

Jaz 2GB Drive External SCSI	629.
Jaz Drive Internal SCSI	299.
Jaz Drive External SCSI	369.
Zip Drive Internal SCSI	149.
Zip Drive External SCSI	149.
3 Pack Jaz Cartridges	240.
10 Pack Zip Cartridges	130.
Single Cartridges for Jaz	89.
Single Cartridge for Zip	13.

External Hard Drives

IBM Chron 2.1GB SCSI 3.5	279.
IBM Capricorn 4.3GB Ultra SCSI 3.5	349.
IBM Capricorn 4.3GB Ultra Wide SCSI 3.5	499.
Quantum Sbrata 2.1GB SCSI 3.5	269.
Quantum Sbrata 4.3GB SCSI 3.5	339.
Quantum Atlas II 4.5 Ultra SCSI AV 3.5	549.
Quantum Atlas II 4.5 Ultra Wide SCSI AV 3.5	699.
Quantum Atlas II 9.1 Ultra SCSI AV 3.5	799.
Quantum Atlas II 9.1 Ultra Wide SCSI AV 3.5	949.
Seagate Cheetah 4.3 14TB SCSI AV 10000RPM	649.
Seagate Cheetah 4.3 14TB SCSI AV 10000RPM	749.
Seagate ST34371N 4.3GB Ultra SCSI 3.5 AV	469.
Seagate ST34371N 4.3GB Ultra SCSI 3.5 AV	529.
Seagate Cheetah 9.1GB Ultra SCSI AV 10000RPM	999.
Seagate Cheetah 9.1GB Ultra SCSI AV 10000RPM	1099.

Software

Microsoft Office 97	299.
Microsoft Word 97	199.
Microsoft Excel 97	199.
Microsoft PowerPoint 97	199.
Macromedia Director	499.
Microsoft Access 97	199.
Adobe Photoshop 4.0	349.
Adobe Pagemaker 6.5	349.
Adobe Illustrator	299.
Macromedia Freehand	299.

Printers

HP DeskJet 340	299.
HP DeskJet 820CX/1870CX	279./399.
HP LaserJet 6LXI/6PXI	385./729.
HP LaserJet 6MP/5M	849./1399.
HP LaserJet 55N	949./1199.
HP LaserJet 4V/4VM	1689./2399.
HP LaserJet 5MX	3399.
HP OfficeJet 590/1150C Pro	599./939.
HP 4000 N	1479.
HP 4007N	1549.
EPSON	
Epson Stylus Color 600/800	259./369.
Epson Stylus Color 3000	1699.
Epson Stylus Photo	369.

Apple Laser 12/640	979.
Apple Laser 16/600PS	1279.
Apple Laser 8500	2299.
Apple Laserwriter 1500	279.
Apple Laserwriter 2200	379.
Apple Laserwriter 2500	189*.
Apple Laserwriter 4100	239.
Apple Laserwriter 4500	339.
Apple Laserwriter 6500	CALL.
Color Portable 2200	279.

computer center

Monitors



Monitors

NEC

A500 15" 28DP 1280X1024	299.
E500 15" 25DP 1280X1024	359.
A700 17" 28DP 1280X1024	579.
P750 17" 25DP 1600X1200	799.
E1100 21" 28DP 1600X1200	1349.
P1150 21" 28DP 1600X1200	1229.
XP37 37" 85MM	7199.

RASTEROPS
MC7515 19" .22DP
1600X1200 Monitor
\$849.

radius

SuperMac 21TXL w/calibrated
SuperMac17XL 17"
Precision View 21"
Presview 21" SR
Presview 17" SR
Thunder 30/1600
Thunder Power 30/1920
Thunder TX 1152
Thunder 3D

RASTEROPS HITACHI 3 year warranty



Mc 620 17" .28dp 1152X870	459.
Mc 6315 17" .22dp 1280X1024	599.
Mc 7515 19" .22dp 1600X1200	849.
Mc 801 21" .22dp 1600X1200	1149.
Mc 801HR 21" .22dp 1600X1280	1299.

SONY

Sony 100ES/GS	329./359.
Sony 200ES 17"	589.
Sony 200GS/PS	639./789.
Sony 400PS	1099.
Sony 300SF 20"	1099.
Sony 20SE II 20"	1649.

ViewSonic

G771 17"	479.
17GA 17" .27DP 1024X768	499.
P775 17" .25DP 1600X1280	579.
PT775 17" .25DP 1600X1280	649.
G800 20" .28DP 1600X1280	899.
G810 21" .28DP 1600X1280	979.
P810 21" .25DP 1600X1200	1079.
P815 21" .25DP 1800X1440	1249.

Apple 850 20" Monitor \$1399

Apple 15" AV	329.
Apple 15"	299.
Apple 1705 17"	549.
Apple 1710 17"	649.
Apple 720 17"	CALL.
Apple 750 17"	799.
Apple 150 AV 17"	899.
Apple 850 AV 20"	1749.

Apple Processors

Apple 132 MHz 604e	129.
Apple 150 MHz 604e	149.
Apple 200 MHz 604e	249.
Apple 233 MHz 604e	399.

newer tech

MAXpower 200MHz 604e with SBT	599.
MAXpower 225MHz 604e with SBT	699.
MAXpower Citation 200MHz 604e no SBT	349.
MAXpower Citation 233MHz 604e no SBT	439.
MAXpower Pro 250MHz 750 512k Bkstd. Cache 1049.	
MAXpower Pro+266MHz 750 1MB Bkstd. Cache 1899.	
NUpower 1400 183MHz 603se 128KL2 Cache	549.
NUpower PB 500 183MHz 603se	699.
VIEWpower PB1400 16bit video card	249.
PC Card Video In/Capture	269.

FedEx
• WE SHIP WORLDWIDE
• NEXT DAY SHIPPING
• SAME DAY SHIPPING

Macintosh Performas

Monitor sold Separately



6360/120* 16/1.2G/CD	CALL.
6400/200* 16/2.4G/8x/VE	CALL.
6400/200* 16/2.4G/8x/CD	CALL.
6400/180 16/1.9G/8x/CD	CALL.
6403/300DS* 12/500/CD/DOS	CALL.
6300/120* 16/1.2G/4x/CD/TV	CALL.
6320/120 16/1.2G/4x/CD/TV	CALL.
6220/75* 16/1.2G/4x/CD	CALL.
6200/75* 8/1.2G/4x/CD	CALL.
5400/120* 16/1.6/8x/CD/15" built in	CALL.
5200/75* 8/800/CD	CALL.
LC580 8/800	CALL.

VST

Powerbook Batteries for 1400,5300,190	119.
Zip 100MB For 5300 & 150	319.
Charger for 1400 w/AC adapter	229.
Charger for 1400 battery & Apple ac Adapt.	129.
3400 Mobility Battery (Charger, AC & Batt)	329.
3400 Apple Li-Ion Battery	149.
Auto Adapter for 3400, 1400 & G3	95.
Power Adapter 3400,5300,G3 & 190	149.
Charger 3400,5300,G3 & 190	149.
Apple AC Adapter 3400 & 1400	65.

Powerbook 3400 & 1400 zip \$319

WACOM

ArtZ 4x5	139.
ArtZ 6x8	289.
ArtZ 12x12	389.
ArtZ 12x18	599.

Tektronix

Phaser 140 COLOR	949.
Phaser 300X COLOR	4999.
Phaser 350 COLOR	2999.
Phaser 380 COLOR	7899.
Phaser 450 COLOR	6099.

Ultimate Rez 8MB Video Card \$549

Nexus GA Rage 8MB WRAM	499.
Xclaim 3D 4MB	CALL.
Xclaim 3D 8MB	CALL.
Video Upgrade 4MB	99.

Fax Modems

GV 56K Teleport Flex	149.
GV 56K PCMCIA for 1400 & 3400c's	259.
GV 56K PCMCIA + Ethernet for 1400 & 3400c's	379.
GV 152 Mercury PB 500 Series	99.
GV 14.4 Gold PCMCIA	65.
Teleport 33.6 v/Voice	89.

US Robotics

Sportster 58K	199.
Sportster 56K PCMCIA	259.
Sportster 33.6K	159.

Memory

16MB Dimm PPC	49.
16MB Simm PerformaPC	49.
16MB for PwBook 1400/3400	49.
24MB for PwBook 1400	149.
32MB Dimm PPC	69.
32MB Simm PerformaPC	69.
32MB for PwBook 1400/3400	179.
64MB Dimm PPC	149.
64MB for PwBook 3400	249.
128MB Simm PPC	489.

Asante

ASANTE 10BT Ethernet	59.
----------------------	-----

PHILIPS/MAGNAVOX 4 YEAR ON SITE WARRANTY!

ASK YOUR SALES REP REGARDING EXTENDED ON-SITE WARRANTY ON NEW AND REFURBISHED PRODUCTS. THE ON-SITE WARRANTY BEGINS 31 DAYS AFTER THE INVOICE DATE IN MOST SITUATIONS.

\$701 to \$1200	\$1201 to \$2000	\$2001 to \$3000	\$3001 to \$4000	\$4001 to \$5000	\$5001 to \$7500	\$7501 to \$10000	\$10001 to \$15000
\$157.99	\$185.99	\$217.99	\$261.99	\$291.99	\$343.99	\$431.99	\$552.99

Visit Us At Our Web Site <http://www.LACC.com>
24Hrs A Day -- On-Line Catalog & Ordering
E-Mail us at: lacc@lacc.com or Call us at (800) 689-3933

All prices subject to change without notice • All Prices reflect cash discount • * reflects Factory refurbished units

TRADE YOUR MAC FOR A NEW ONE. We Pay Top \$\$\$ For Your Mac & Mem.

Competitive Leasing **BUY • SELL • TRADE** We custom configure and test your system.
 Email: cgn @ cgnusa.com

PowerMacs	Powerbooks	Upgrades	Demo Macs	Memory	Parts
G3 266 Mhz/32/4gb/CD 1750 G3 233 Mhz/32/4gb/CD 1750 9600 350 MHz 4199 9600 300 MHz 2840 8600 250 32-4GB-CD 2190 7300 180 Mhz 1299 8500 132 MHz 1390	3400C 240 Mhz 3495 3400C 200Mhz 2790 3400C 180 Mhz 2550 1400C 16-1GB-CD 2090 2400cs 12/750 2545 Call for New PB 3400 Demo Powerbooks 5300CS 16/500 1050 540C 12/500/Mod 999 5300c 16/750 1299 145 - 170 -180c-165c CALL 5300C 16/500 Actv 1290	Same day Upgrade No down Time!! Prf 63X to 6300 603-75Mhz 490 7200 to 7600 525 8100 to 8500 850 7500 to 604-200/233 275/399 Call for PowerBook Upgde Q800- Q840 to 8500 825 7100 to 7500/100 599 7200 to 7500/100 425 Q800-840 to 8100 490 PB 5300 to 3400/CD Call Call for Upgrades not listed	8500 120/132 1299/1390 7500 /7600 990/1195 9500 1450 8100/100 16/1GB/CD 890 Q 800/ 840/950 450/550 7100/80 650 15" / 17" Monitor 250 / 420 Mac Ilci 99 Performa 6400-200 16/1GB CD 990 Call for latest prices. 6320/6400/4400/6500	Dimms 16/32/64 45 /79/139 30 Pin 1/ 4/16 8 / 13/ 55 72 Pin 8/16/32 32 /45 /75 2X - 4X-8x CD 50 /95/109 HD 1.GB - 2.GB-4GB Call Iomega JAZZ Drive 299 Global Village Modem 169	Floppy 1.44 75 POWER SUPPLIES CALL AV Card \$175 Power supply Cx Ci 7100 45 Call for Logic Boards & more Computer Graphics & Networking All prices Reflect cash Discount Visa, Mastercard, Amex Accepted << Prices are subject to Change.>>

Call For G3 New Sys.
4400 200Mhz 1095
7200 /75/90/120 CALL
Call for config. not listed

TEL: 310-441-4771 10922 W. Pico Blvd. Los Angeles, CA 90064 Fax: 310-441-4770

CompuMall

Your Premier Computer Source

1-800-977-5665
www.computerstogo.com

PowerMacs	PowerBooks
G3/233 32-4GB, CD \$1695	3400C/240 16-3GB, CD \$2895
G3/266 32-4GB, CD, Zip \$2050	3400C/200 16-2GB, CD \$2485
G3/266 Tower 32-6GB, Zip \$2475	1400C/166 32-2GB, CD, 33.6K \$2045
9600/350 64-4GB, CD \$2995	1400C/166 16-2GB, 8xCD \$1795
9600/300 64-4GB, CD, Zip \$2595	1400CS/166 16-2GB \$1425
8600/300 32-4GB, CD, Zip \$2095	Duo2300C/100 8-750MB \$995
7300/180 16-2GB, CD \$1195	Duo2400C/180 16-1.3GB \$1795
4400/200DOS 32-2GB, CD \$1365	32/64MB Memory \$45/95/175

www.computerstogo.com 1-800-977-5665 Prices are based on C.O.D. order & subject to change!

www.computerstogo.com

PowerMac
9600/350
256MB-9GB, CD, Zip
\$4045

Best Buys
DOS Card
P/166, Win 95
\$495

PowerBook
G3/250
32-5GB, 20xCD
\$3795

We offer the Full Line of
HEWLETT PACKARD Printers
Best Values! Call Today

CDR Media
10 Pack \$24
100+ \$1.49

Sales: (818)787-1054 Fax: (818)787-3111 MWCM0498
 e-mail: csales@pacifinet.net Visit our Web Site
 6735 Van Nuys Blvd., Van Nuys, CA 91405 for the latest information & Prices.

Specializing in Rebuilt Imagesetters complete

PrePress Systems and Digital Video 3101 W.PCH suite 150
 phone 714-574-3939 fax 714-574-3947
 email: Glucero126@aol.com
 NewPort Beach Ca 92663

We Custom Configure

Pre Press System

Complete Color Pre Press System
 Includes Power Mac 7500
 24/1G, 17" Color
 Monitor, Software, Ex
 Keybd, AGFA Color
 Scanner, Color Proof
 Printer, Imagesetter w/Rip
 & Processor.
\$16,950

SilkScreening System

Imagesetter - Agfa or Linotype 18" Wide
 • includes RIP
 • Adobe Postscript
 • 2400 DPI
 • Factory Refurbished
 • Call for New & Refurbs

\$15,000

AGFA • Linotype • ECRM • Ulte • Scitex • MACINTOSH

Scitex Station

PM 9600/300/128MB/3GB/CD/ATI
 Targa 2000, Microsphere
 The only Real Time...All the
 Time system in the quicktime
 market to provide unimagina-
 ble real time effects.

Accessories
 Howtek Drum Scanner
 Flatbed Scanners
 Pantone • Scanview
 Proofing Printers
 Epson • Fargo • Barco
 IRIS • Seal • Visual Edge
 Call for Pre Press needs

Software
 After Effects ..\$1575
 Form Z.....\$1495
 Borris Effects..\$495
 Final Effects.....\$575
 Photoshop.....\$395
 Page Maker.....\$495
 Illustrator.....\$350

AVID® MCXPRESS MAC
 Workstation for Macintosh
 SYSTEM INCLUDES: Real Time
 effects, country kit 110v, bet-
 cam video, avid standards
 effects, Single Channel Controller
 2 Channel Audio, Film Option,
 Deck Control, & 3D. Note:
 Options not included
Starting at 9,995

Media 100 Station
 9600/300MHz, 128MB/4G/CD
 After Effects 3.0, 17" Monitor,
 Keyboard, 4100 w/SCSI Wide Array,
 Vicent Component, Batch Capture
Starting at 14,900

voice: 510-689-9488 fax: 510-689-9487 PRICES & QUANTITIES SUBJECT TO CHANGE Place Your Orders OnLine!

1-888-447-3728 • MacResQ • www.macresq.com

<p>Toll Free SEAGATE 2.1 Gig 3.5" internal SCSI hard drives \$179</p> <p>Mac OS</p>	<p>PARTS, PARTS, PARTS!!</p> <p>CD 300i+ (tray) internal \$49 CD 600i (tray) internal \$79 CD 1200i (tray) internal \$89 CD 1800i (tray) internal \$199 *mounting kits OR external cases avail.* Manual inject floppies (661-0121)exch \$49 Auto inject floppies (661-0474)exch \$79 PB 100 & 500 series floppies-exch \$89 PM 6100 DOS cards \$69 Apple Processor Cards: 132/166 \$49/\$99</p>	<p>MONITORS</p> <p>Apple 13" RGB Display \$149 Apple 14" Multi-scan \$229 Apple 15" Multi-scan \$279 Apple 17" Multi-scan \$499</p> <p>Mac OS 7.6: \$18.99 (CD Rom or floppy)</p> <p>16mb EDO DIMMS 6500/5500/7500/7600/ 8500/8600/9500/9600 \$35</p>	<p>Duo 2300c 36/75014.4 \$999</p> <p>Duo 280 32/24014.4 \$549</p> <p>Duo Dock I \$199 (w/ color lid upgrade)</p>	<p>POWER SUPPLIES (EXCH. ONLY)</p> <p>LC thru Q 605 \$19 Mac II cx/ci / Q 700 \$49 Q 800 / PM 8100 \$99 PM 8500 / 9500 \$109 PERF. 630 thru 6200 \$69 Duo Dock \$69 Q 900 / 950 \$99 PM 7100 \$69 PM 6100 \$89 II SI \$49</p>	<p>Apple Color LW 12/660 \$2499</p> <p>w/NEW Access. Kit</p> <p>MR Mac-Res-Q</p>
---	---	--	--	---	---

PowerBook Screen Repair...only at MacResQ! call for more DETAILS!
 We can repair: scratched screens, bad pixels, lines, & dead screens- priced from \$199

25% re-stocking fee- ALL ITEMS REFURBISHED UNLESS NOTED AS NEW • All Parts Sold With a 90 Day MacResQ Exchange Warranty • Exch. Required For ALL Power Supplies All Major Credit Cards With NO Surcharge. • CIRCLE 458 ON READER SERVICE CARD

MANUFACTURER'S WAREHOUSE SALE!

THOUSANDS OF NEW AND FACTORY RECERTIFIED
OVERSTOCK COMPUTERS, MONITORS, VIDEO CARDS & PRINTERS

CRA Continues to bring the BEST DEALS on Factory Overstock and hard to find computer items!

MONITORS

SONY 20" TRINITRON BLOWOUT!



- 20 inch at 17 inch price!!!!
 - 19 inch viewable screen area
 - Industrial grade design for longer tube life and less interference
- Quantities Limited!!

TRUCKLOAD SALE!!!

20" COLOR MONITORS

- 20" Sony Trinitron \$699
- 20" Multi-Resolution \$899
- Radius PrecisionColor 20v **Call**
- Radius Intellicolor 20 from \$1099

21" COLOR MONITORS

- SuperMac 21" Color Display from \$999!
- Ikegami 21" Diamondtron NEW! \$1299
- Radius PrecisionView 21 \$1399
- Radius 21" PressViews from \$1459

17 INCH COLOR MONITOR

- SuperMac 17 Multi-Scan \$399!
- Radius PrecisionColor 17 \$599
- Portrait Display Labs 1700 NEW! from \$799

15 INCH MONITORS

- PrecisionColor Pivot \$399
- Radius 15" Pivot, Color & Grayscale from \$199

GRAYSCALE MONITORS

- Two Page Grayscale from \$499!
- Radius Full Page Display \$299
- 21" Grayscale Display NEW! \$599

NEC, Sony, Mitsubishi, Viewsonic, Apple Monitors Also Available!!!

DIGITAL VIDEO

- VideoVision Studio from \$899
- VideoVision Telecast from \$999
- VideoVision Studio Array from \$799
- Video Spigot Cards from \$99
- Spigot II Tape, Spigot Nubus, LC & IISI
- Video Spigot Power & Pro AV from \$199
- FULL MOTION, full screen capture and playback

VIDEOVISION

Available in Nubus and PCI

- Broadcast quality video output
- Proven Non-Linear Video editing technology

was \$2999

from \$899!

G3 SPECIAL!

Bring Your Older Mac Back to Life!

New G3 Processor Upgrade Cards
for 6100, 7100, 8100 from \$499*

*With Purchase Of Qualifying VideoCard or Monitor

GRAPHICS CARDS

Accelerate The Video
on Your Nubus Mac!
from \$99!

We offer the world's largest supply of graphics cards for
older Mac II, Quadra and Nubus PowerMacs

NUBUS CARDS

- 17" 832 X 624 Resolution from \$99
- 20" 1024 X 768 Resolution from \$299
- 21" 1152 X 870 Resolution from \$399
- Thunder II Series w/DSP acceleration from \$399
- PhotoEngine \$199

PCI CARDS

- IMS Twin Turbo from \$199
- Thunder 30 from \$499
- ThunderColor 30 from \$999
- ThunderPower 30 from \$Call

PRINTERS

- Apple LaserWriter 8ppm \$199
- Apple LaserWriter IIint 8ppm \$299
- Apple LaserWriter NTR \$899
- 4ppm, Local Talk, 2 paper trays
- Apple LaserWriter 4/600PS \$599
- 4ppm, 600dpi, Postscript Level 2
- Apple LaserWriter Select 360 \$499
- 10ppm, 600dpi, Postscript Level 2
- Apple LaserWriter Pro 630 \$899
- 8ppm, 600dpi, Local Talk/Ethernet, Postscript Level 2
- Apple LaserWriter Pro 600 \$699
- 8ppm, 600dpi, Local Talk
- QMS 825 \$399
- 8ppm, Local Talk/Ethernet, Postscript Level 2, Dual paper trays
- QMS 860 Hammerhead (600dpi tabloid) NEW! \$1599
- 16ppm, Local Talk/Ethernet, Postscript Level 2
- QMS PS 1700 \$699
- 17ppm, Local Talk/Ethernet, Postscript Level 2
- SuperMac Proof Positive \$1999
- Dye-Sublimation Printer, Photo-Realistic
- Available as Full Page Or Tabloid

*With Qualifying Monitor or Video Card Purchase

COMPUTERS

APPLE

- PowerMac G3/266MT \$3499*
- PowerMac 8500 32mb/2gb/8xcd \$1599*
- PowerMac 6500/300 64mb/4gb/12xcd \$2199*
- PowerMac 8600/300 32mb/4gb/24xcd \$2499*
- PowerMac 9600/300 64mb/4gb/24xcd/Zip Drive \$2799*

UMAX

- SuperMac C500 Series \$799*
- SuperMac C600 Series \$1099*
- SuperMac J700 Series \$1399*
- SuperMac S900 Series \$1899*

MOTOROLA

- StarMax 3000 603e processor \$799*
- Desktop and Minitowers available
- StarMax 4000 604e processor \$999*
- Desktop and Minitowers available

* with purchase of qualifying in stock monitor or video card

Complete Systems

- PowerMac G3 & 20" Trinitron only \$2899
- 233MHz & 266MHz Processors Available
- PowerMac 8500 & 20" Trinitron only \$2199
- 32/2gb/8xcd 24bit Color card
- Mac IIVx, 17" Color Monitor and P/S Printer only \$995

Accelerated Graphics Workstation

- PowerMac 81/110 32mb/2GB/8xCD only \$1795
- 20" Color Monitor
- 24bit Color Card

Mac IIVx

- 4mb/160 HardDrive
- 15" Grayscale Pivot
- Color Monitors Available



\$295!

DIGITAL WORKSTATION

Complete Package!!

\$2399!

- PowerMac 81/110
- 32/2GB/8XCD
- 17" Color Monitor
- VideoVision Studio 2.5.1
- Adobe Premiere



4 YEAR EXTENDED WARRANTIES AVAILABLE ON MOST PRODUCTS

CRA Systems, Inc. www.crasystems.com 800-375-9000



CRA Systems, Inc. 300 South 13th St., Waco, TX 76701 Monday thru Friday 9AM to 7PM CST Saturday 10AM-4PM Sales Dept. Only
Domestic Sales sales@crasystems.com Fax 254.750.9050 Consultants/Dealers 254.754.2120 International Sales 254.754.2120
Prices reflect 2% cash discount. Prices subject to change. Not liable for typographical errors. Dealers and consultants call for quantity pricing. We ship anywhere.
All Monitors, Printers, and CPU's are Factory Recertified unless otherwise stated. Call for latest pricing & availability on NEW Options.



POWERMAC 4400
200Mhz 32/2GB/12XCD/KB/DOS
\$1289

POWERMAC 9600
350Mhz 604e/64/4GB/24XCD
\$3279

POWERMAC G3
233 Mhz/32/4GB/24XCD
\$1695

POWERMACS

G3
266Mhz Minitower /32/6GB/24xCD/Zip/AV\$2699
266Mhz Desktop /32/4GB/24xCD/Zip\$2049
233Mhz Desktop /32/4GB/24xCD\$1695

9600
350Mhz 604e/64/4GB/24xCD\$3279
300Mhz 604e/64/4GB/24xCD\$2759
233Mhz 604e/32/4GB/12xCD/L2Cache\$2595
200 Mhz MP604e/32/4GB/12xCD/L2Cache\$2699
200 Mhz 604e/32/4GB/12xCD/L2Cache\$2098

8600
300Mhz 604e/32/4GB/24XCD/L2\$2195
250Mhz 604e/32/4GB/24XCD/L2\$2095
200Mhz 604e/32/2GB/12XCD/L2\$1895

7300
200 Mhz 604e 32/2GB/12xCD/L2\$1398
180Mhz 604e 32/2GB/12xCD/DOS\$1689
180Mhz 604e 16/2GB/12xCD/L2 Cache\$1299

6500
300 Mhz 64/6GB/24XCD/L2/ZIP/56.6 Mod\$2289
275Mhz 48/6GB/24XCD/L2/ZIP/56.6 Mod\$1999
275Mhz 32/6GB/24XCD/L2/ZIP/56.6 Mod\$1949
250Mhz 32/4GB/24XCD/ZIP/56.6 Mod\$1399
225 Mhz 32/3GB/12XCD/L2/33.6\$1229

4400
200Mhz 16/2GB/CD\$1179
200Mhz 32/2GB/12XCD/KB/DOS\$1289

PERFORMAS

6400 200MHz/16/1.6GB/CD/KB\$998
6360 160MHz/16/1GB/CD/KB\$799*
6205 75MHz/8/1GB/CD/KB\$599*

UPGRADES

WITH ORIGINAL APPLE LOGIC BOARD

PM 8500 LOGIC BOARD UPGRADE
FROM Q800, Q840AV, PM 8100 TO 8500\$995
PM 7600 LOGIC BOARD UPGRADE
FROM PM 7200 TO 7600\$495
PM 5300/6300 UPGRADE L.B.(100MHZ)
FROM Q630, PF630, PF 5200 & 6200\$349
Workgroup Server 9150/80 L.B. Upgrade
FROM 950, 900\$599
DUO UPGRADE 200 Series To 2300\$599
200MHz Processor Upgrade\$289

Prices Subject to Change Without Notice
All Prices reflect 3% Cash Discount * Refurbished



ICN

INNOVATIVE COMPUTER & NETWORKING, INC.

APPLE ORIGINAL
12XCD-ROM
\$169

Upgrade your
7200 To 7600 \$495
Apple Original Upgrade

ICN #1

Independent Parts Distributor

Over 15000 different Apple parts in stock
Next day delivery on all exchange parts.

POWERBOOKS

G3 250 Mhz/32/5GB/20xCD\$4449
3400c 240 Mhz/16/3GB/CD\$3049
3400c 200 Mhz/16/2GB/CD\$2689
3400c 180 Mhz/16/1.3GB/CD\$Call
2400c 180 Mhz/16/1.3GB\$1949
1400cs 133 Mhz /16/1.3GB/CD\$1779
1400c 166 Mhz/16/2GB/CD\$1895
DUO 2300c 100Mhz/20/1GB/Mod*\$1429
5300ce 117 Mhz/16/1GB*\$1649
5300c 100 Mhz/16/750*\$1395
5300cs 100 Mhz/8/500*\$1079

PowerBook 100 & 500 Series In Stock

Duo Upgrade
200 Series To 2300 Series
\$595

APPLE 166Mhz
Pentium Dos Card \$589

FOR CURRENT PRICES VISIT OUR WEB SITE AT:

<http://www.icni.com>

1.888.505.2211
Fax:(310)445-6611 Tel:(310)445-6600
FAX TOLL FREE FROM JAPAN: 00-31-114211
2045-B S. Barrington Ave. LA, CA 90025

*OLD PROCESSOR CARD IS REQUIRED TO BE EXCHANGED WITH THE NEW ONE

PERFORMA 6400
200 MHz/16/1.6GB/8XCD/KYBD
\$998

POWERBOOK G3
250 MHz/32/5GB/20XCD
\$4395

POWERMAC G3
266 MHz/32/4GB/24XCD/Zip
Desktop
\$2049

MONITORS

APPLE VISION 850\$1429
APPLE 20" Multi*\$1929
APPLE VISION 750\$689
APPLE VISION 750 AV\$859
APPLE 1705 Multi\$399*
APPLE 15" AV Multi\$329
NEC E500/E700\$388-659
NEC 21" P1150/E1100\$1439-1299
SONY 15" 100ES/15"100GS\$349-379
SONY 17" 200ES/17"200GS\$598-669
SONY 20" 300SF/ 21" 500PS\$1189-1689
VIEWSONIC 15" GS/ GA\$319-339
VIEWSONIC 17" GA/ PT770\$559-649
VIEWSONIC 20" G800/ GT800\$1029-1229
VIEWSONIC 21" P810/ P815\$1169-1449



PRINTERS

APPLE LaserWriter COLOR 12/660\$3695
APPLE LaserWriter 12/640\$999
APPLE LaserWriter 8500\$2329
APPLE LW 16/600\$1389
APPLE LW 4/600\$689
APPLE LW Color 2500\$239
APPLE SW 1500\$169*
APPLE SW 1200\$139
APPLE SW Color 4100\$249
APPLE SW Color 4500\$339
APPLE SW Color 6500\$449
HP LASER JET 6MP\$839
EPSON STYLUS 600/800 COLOR\$249/\$339



SCANNER

AGFA Arcus II Transp/Full Photoshop\$1499
UMAX ASTRA 1200S - Photo D/Full Photo.\$279/\$449
UMAX ASTRA 610S / Photo Delux.\$179
CALL FOR PRICES ON OTHER MODELS

APPLE PARTS & ACCESSORIES

APPLE 166MHz Pentium Dos Card\$589
Apple 166Mhz for 4400\$295
Original Apple BATTERY For PB 3400\$129
Original Apple 12xCD-ROM\$159
Apple Parts CatalogCall



**IXMICRO
TWIN TURBO
8MB \$349
4MB \$189**



**WESTERN
DIGITAL
2GB HARD
DISK \$199!**



CUSTOM CONFIGURATIONS

a division of BASEONE computers.

LEASING PLANS AVAILABLE



AWESOME NEW LOOK AND FEATURES!

WWW.MACBASE.COM

ONLINE DETAILED SYSTEM CONFIGURATION, ADVISE MODULE, ACCURATE AND UP TO DATE PRICING, KILLER INTERFACE.

604E
6 PCI 1MB CACHE
63 UPGRADABLE
8 DIMM SLOTS
8 HD BAYS

**POWER
PTP 225E
96/2G/24XCD
\$1999***

**ACTIVE
MATRIX!**

**POWERBOOK
3400/200MHZ
16/2G/12XCD
NO MDM \$2759**

SONY
Trinitron
25 DOT

**POWER
COMPUTING
24" COLOR
\$2699**

**LAST
CHANCE!**

**6360/160MHZ
16/1.2G/CD/MDM
KEYBOARD \$799***

**UNDER
\$1000!**

**6400/180MHZ
16/1.6G/CD/MDM
KEYBOARD \$989***

POWERMAC

Performa 6205/75	8/1G/CD	649*
Performa 6230/75	16/1G/CD/TV	689*
Performa 6360/160	16/1G/CD	799*
Performa 6400/180	16/1.6G/CD	989*
4400/200	16/2G/8XCD	1199
4400/200	SMALL BUSINESS	1499
4400/200	PC COMPATIBLE	1299
6500/225	32/3G/12X/MDM/HM	1299
6500/225	48/6G/24X/ZIP/OFF	1989
6500/300	48/4G/CD/ZIP	2119
7300/180	16/2GB/CD	1299
7300/180	DOS 32M/16D/2GB	1799
7300/200	32/2GB/CD	1499
8600/250	32/4G/24XCD/ZIP	2239
8600/300	32/4GB/24XCD	2179
8600/300	32/4GB/24XCD/ZI	2299
9600/200	32/4GB/CD	2149
9600/300	64/4GB/24XCD	2829
9600/300	64/4GB/24XCD/ZIP	2979
9600/350	64/4GB/24XCD	3549
9600/350	64/4GB/24XCD/ZIP	3699
G3 DT/233	32/4G/24XCD	1799
G3 DT/266	32/4G/24X/ZIP	2149
G3 MT/266	32/6G/24X/ZIP/AV	2689
PowerWave 132/604	16/1G/CD	999*
PTP225/604e	96/2G/24XCD	1999*
PTP200/604e	96/2G/24XCD	1799*
PCP240/604e	64/2G/16XCD	2099*
PCP210/604e	64/2G/16XCD	1299*
PHILLIPS ONSITE EXTENDED		

POWERBOOK

DUO DOCK II PLUS	399	
DUO 2400C	16/1.3G	1899
1400C/166	16/1GB/CD	1899
5300C/100	16/1.1GB	1399*
3400C/200	16/2G/12X/NOMD	2759
3400C/200	16/2G/12XCD/MDM	2999
3400C/240	16/3G/12X/NOMD	3159
3400C/240	16/3G/12XCD/MDM	3399
G3/250 32/5G/20XCD/NOMDM	4599	
G3/250 32/5G/20XCD/MDM	5099	
3400/5300 BATTERY	129/139	
8XCD FOR 1400	189	
6XCD FOR 3400	149	
8BIT VIDEO FOR 1400	159	
ACTION 33.6 PCMCIA	149	
GLOBAL VILLAGE 56.6K PCMCIA	259	

STORAGE

WesternDigital 2.1G SCSI (3.5in)	199
SEAGATE 4.3GB Barracuda (3.5in)	339
SEAGATE 9.1GB Barracuda (3.5in)	799
SEAGATE 23GB Elite (5.25in)	1799
EZQuest JAZ 1GB External	339
EZQuest JAZ 2GB External	549
EZQuest 2X2X6 CRW External	449
EZQuest 2X6 CDR External	399
EZQuest 9GB UW RAID	1399
IOMEGA ZIP/JAZ Xternal	149/379
IOMEGA ZIP/JAZ Internal	129/309

PRINTERS

Apple SW 1500 /2500	149*/219*
SW 4500/6500	349/459
Apple LW 12/640	999
Apple LW 16/600 REF	1159
Apple LW 16/600	1439
Apple LW 8500/20 (20PPM)	2299
Apple LW COLOR 12/660	3699
EPSON STYLUS 600/800	269/369
EPSON STYLUS 1520/3000	779/1699
HP 870CXI / 6MP	479/869
HP 5M / 4MV	1529 /2299
HP 4000	1579

MONITORS

POWER 17 INCH NEW	499
POWER 24 INCH TRINITRON!	2799
Apple 15" / 15AV	259*/299*
Apple 15AV 15" NEW	339
Apple 17" 17"	599
AppleVision 750 / 750AV	799/949
Apple 850 20" / 850AV	1449/1799
NEC A500/A700/M700	329/579/759
NEC P1150 20"	1689
Sony 100SX/300SF	
299/1199	
Sony 100ES/200ES	349/589
Sony 100GS/200GS	379/639
Sony 200PS/400PS	799/1199
VIEWSONIC V773/ G810	489/1099

SCANNERS

UMAX Astra 610S	169
UMAX Astra 1200s - PhotoDelux	279
UMAX Astra 1200s - Full Photoshop479	
UMAX PowerLook II - Full Photo	1299
UMAX Mirage Iise - PhotoPerfect	3299
UMAX PowerLook III - Full Photo	3399
UMAX Mirage II - Full Photo	7999
AGFA SnapScan 310 - ColorIt/OCR	249
AGFA StudioStar - Full Photo	879
AGFA StudioStar - PhotoShop le	749
AGFA Arcus II - Full Photo	1549
AGFA DUOSCAN - Full Photo	3050
Microtek Scanmaker V300	199
Microtek Scanmaker III Full Photo	1399
Microtek Scanmaker E6 Std	489
Epson ES-1000C	585
Epson Expression 636 Executive	735

SOFTWARE

ADOBE PHOTOSHOP 4.0	329
ADOBE ILLUSTRATOR 7.0	249
ADOBE PAGEMAKER	329
ADOBE AFTEREFFECT Production	1279
QUICKEN 7.0	29
MACROMEDIA FREEHAND	249
MACROMEDIA DIRECTOR 5.0	759
MICROSOFT OFFICE	249
QUARK EXPRESS	699
APPLE MAGIC COLLECTION CD	29

Real People, Real Product, Real Prices!
800-951-1230

Int'l (714) 428-0777 University, School, Government & Fortune 1000 P.O.'s Accepted! FAX (714) 428-0778

FedEx We ship Worldwide! Dealers inquiries welcome. Returns subject to restocking fee. Prices reflect C.O.D. or CASH and are subject to change without notice. P.O.'s subject to approval.



Apple G3
As Low As
\$1589

The Lowest Finance Rate Available FREE Software SuperBundle - \$3500 Value

Software SuperBundle - Director, Adobe Premiere, Illustrator, PageMaker, Photoshop, LivePicture, Omni page Professional, DOS Mounter 95 Free with this Ultimate Workstation.

FULL-LINE AUTHORIZED SERVICE CENTER - MAC & PC EQUIPMENT REPAIR, DATA RECOVERY, SHORT-TERM RENTAL, LOANER PROGRAM AND POWERPC PROCESSOR - 120/132/150/180/225/233/250/300/350 MHZ 200MHZ UPGRADE AVAILABLE AS LOW AS \$199.

SUPERBUNDLE!
\$349
PER MONTH

- PowerPC G3/266MHZ or PowerTower Pro 250MHZ MP
- Internal 24x CD-ROM
- **416 MB RAM**
- 18GB internal RAID Disk
- Extended keyboard
- \$1489** • Radius PrecisionColor 21" Color - 1600X1200 0.25mm Color monitor
- \$429** • Twin-Turbo -128bit Graphic Engine, 1600x1200, w/8MB Graphic Engine
- \$1349** • Agfa Arcus II w/ Trans.36-bit Scanner

- \$899** • External combo drive w/Jaz drive ,ZIP ,SQ200MB w/Cart.
- \$649** • Apple LaserWriter 600dpi PostScript printer 4/600 w/one cartridge and Cables
- Active SCSI terminator, One 25/50 SCSI cable, five 50/50 cables
- \$89** • UPS Battery Back-Up
- \$199** • Apple QuickDraw 3D PCI Accelerator Card - 12 X Faster
- Image Solutions Extended Services



Power Macintosh G3 Ultimate Graphics Workstation

Adobe Specials - PageMill 2 - \$89 (MAC & Win.)

- Adobe Photoshop 4.0/Retail \$279/\$325
- Adobe Photoshop 3.0.5/LE \$199/\$99
- Adobe Illustrator 5.5/7.0 \$199/\$289
- Adobe PageMaker V6.0/V6.5 \$199/\$289
- Adobe Premiere 1.0.1/4.2 \$99/\$329
- AfterEffects/Product. Bndle \$479/\$1689
- Persuasion V3/Dimension3 \$229/\$125
- Acrobat V3.0/Type-on-Call \$149/\$39
- FrameMakerV5/Streamline4 \$469/\$125
- Adobe PhotoDeluxe/ATM \$35/\$59

MacroMedia sales - Director 5 - \$189 (MAC & Win.)

- Authorware 3/Inte. Studio \$489/\$979
- Authorware 4/Inte. Studio \$1529/\$2529
- Director5/Multimedia Studio \$189/\$289
- Director6/Multimedia Studio \$589/\$749
- Freehand 7/Graphics Studio \$289/\$349
- Macro. Fontographer/ Flash 2 \$199/\$169
- Macromedia xRes / Ex. 3D \$99/\$99
- SoundEdit 16+ / DECK II \$189/\$249

Microsoft sales - Office V4.2.1 - \$149 (MAC & Win.)

- Microsoft Office 4.2.1 /97 \$199/\$289/\$329
- Microsoft Word 6.0.1/Excell V5 \$199
- M.S.Project v4/FrontPage \$249/\$99
- PowerPoint 4/Works 4 \$199/\$99

MetaCreation - Infini-D4 - \$459 (MAC & Win.)

- F.D. 3D STE/ Bryce 2 \$329/\$159
- F.D. Detailer / Expression \$249/\$119
- F.D. Painter V3/4/5 \$129/\$179/\$239
- FD Poser v2/Dabbler V2 \$115/\$38
- Kai's Power Tool V2/3/5E \$49/\$119/\$69
- Ray Dream Designer/Studio \$85/\$229
- BackStage Studio / StudioVision Pro \$329/\$689
- ElectricImage Broadcast / JMP 3.2 \$1689/\$479
- Hollywood FAX/ Hyper Studio \$489/\$179
- Illuminaire Paint / Presenter 3D 3.6 \$889/\$1389
- LightWave 3D 5.0/5.5 / Aurorix \$1189/\$1389/\$259

Monitor & Display Card

- DSC 15"/17" Color \$249/\$395
- DSC 19"/20" Color \$849/\$989
- ViewSonic 17"/19" \$549/\$949
- Radius17"/21" Color \$639/\$1589
- IMS 4MB/8MB 3D \$285/\$445

Printer STY1500 \$199

- EpsonStylus3000 \$Lowest
- Apple Laser 4/600 \$649
- HP 4MV 11x17 \$2389
- GCC XL1208, 11x17 \$3869
- Apple12/600 Color \$3589*

Ext. H/D, DAT Tape, MO, SyQ & CDR Devices

(Minus \$39 for Internal Drive)

	Ext.	Turbo
42MB/230MB/540MB /750MB	\$89/\$129/\$149/\$199	-\$25
1GB/2GB/3.2GB/4.1GB	\$189/\$249/\$305/\$359	-\$25
6.4GB/8.4GB/9.1GB	\$449/\$629/\$899	+\$25
7200rpm 4.5GB IBM/Quantum/Seagate	\$519/\$529/\$599	-\$29
Seagate/Quantum/Fuji 9.0GB 7200rpm	\$889	+\$49
SONY DAT 4000/5000/7000	\$679/\$779/\$879	+\$89
DLT Tape Drive 30GB/40GB	\$2649/\$3149	+\$99
ExtraByte 5GB Tape Dr.	\$1199	\$1249
SyQuest 270/200MB Ext. Drive	\$299/\$339	+\$25
SyQuest E2155/E2220	\$109/\$145	+\$25
Panasonic 650MB M.O. Dr.	\$699	\$749
SONY 1.3GB M.O. Drive	\$989	\$1099
Mitsubishi 4.6GB M.O.	\$979	+\$99
Olympus 230MB/2.6GB M.O. Drive	\$309/\$1649	+\$99
Fujitsu 230/640 MB M.O. Drive	\$469/\$599	+\$49
Phillips/Ricoh Rewritable CDR 6X/2X	\$509/\$529	+\$89
SONY CDR 6X/2X w/Toast	\$379	\$429
Yamaha CDR 6X/4X w/Toast	\$599	\$629
Ext. Jaz/Zip & DiskArrays	Ext.	Turbo
10Mega Zip ext. Dr.	\$135	\$155
Jaz ext. Dr. 1GB/2GB	\$289/\$549	+\$25
Jaz + CDR ext. Dr w/SW	\$779	\$989
SyJet 1.5GB Dr. w/2X cart.	\$385	\$429
4GB DiskArray	\$689	\$749
8GB F&W DiskArray	\$1389	\$1489
18GB F&W DiskArray	\$2449	\$2599
36GB F&W DiskArray	\$3989	\$4099

Scanner: Polaroid 35LE - \$739

Epson 836/636	\$2449/\$689
LinoColor JADEII /SAPHIR	\$445/\$1379
Microtek V300/E3/E6	\$135/\$145/\$269
UMAX Astra 610 /1200	\$125/\$245
UMAX PowerLook III/3000	\$CALL/\$CALL
Agfa StudioStar / Arcus II	\$729/\$1229
Nikon CoolScan / Super	\$875/\$1599

Optical

- 74Min CD \$2.49
- DSC 128MB \$7.49
- DSC 230MB \$9.79
- DSC 650MB \$28.99
- DSC 1.2GB \$37.99

DIRECTOR
5 ONLY
\$99 w/
\$1000
PURCHASE

Memory

	30 pin	72 pin	168 pin
4MB	\$25	\$19	-
8MB	\$37	\$27	\$27
16MB	\$35	\$35	\$35
32MB	-	\$69	\$69
64MB	-	-	\$139

Monitor & Display Card

- DSC 15"/17" Color \$249/\$395
- DSC 19"/20" Color \$849/\$989
- ViewSonic 17"/19" \$549/\$949
- Radius17"/21" Color \$639/\$1589
- IMS 4MB/8MB 3D \$285/\$445

Printer STY1500 \$199

- EpsonStylus3000 \$Lowest
- Apple Laser 4/600 \$649
- HP 4MV 11x17 \$2389
- GCC XL1208, 11x17 \$3869
- Apple12/600 Color \$3589*

800-352-3420

Fax: 310-782-5974

Email: imagesol@earthlink.net

http://www.imagesolution.com

385 Van Ness Ave. #110 • Torrance, CA 90501



Order from 6 to 9 weekdays, weekends from 9 to 9. Visit our showroom 9 to 6 weekdays, weekends by appointment.

Prices subject to change without notice. Not responsible for typographical errors. 24 hour replacement limited to products in stock.



Image
Solutions

Shop at the most complete WEB

WWW.MACTOGO.COM

MAC TO GO

your #1 Apple Super Source

Power Macintosh® G3/233 32/4G/CD/KB 32/4G/CD/KB/56K \$1789 \$1859	Power Macintosh® G3/266 266MHz \$2099 32/4GB/24xCD Zip/DeskTop	Power Macintosh® G3/266 266MHz \$2699 32/6GB/24xCD Zip/AV/Tower	Power Macintosh® G3/266 266MHz \$3799 128/4GBUW/CD Zip/Tower/100BT	Power Macintosh® 4400 200MHz 200 DOS 16/2G/CD/KB 32/2G/CD/KB \$1199 \$1299
---	---	--	---	---

Power Macintosh® 7300 180MHz 200MHz 16/2G/CD/KB 32/2G/CD/KB \$1349 \$1449	Power Macintosh® 6500 225MHz 250 MHz 32/3G/CD/KB 32/4G/24XCD/56K \$1219 \$1449	Power Macintosh® 6500 275MHz 275 MHz 32/6G/24xCD/Zip 48/6G/24XCD/Office \$1669 \$1939	Power Macintosh® 6500 300MHz 300MHz 64/4G/12XCD/Zip 64/6G/24XCD/Zip \$1899 \$2099	Power Macintosh® 8600 250MHz \$2199 32/4G/24xCD ZIP/KB
--	---	--	--	---

Powerbook® G3/250 250MHz \$4499 32/5GB/20xCD ACTIVE	Power Macintosh® 8600 300MHz \$2259 32/4G/24xCD ZIP/KB	Power Macintosh® 9600 200MHz 200MP 32/4G/CD/KB 32/4G/CD/KB \$2089 \$3099	Power Macintosh® 9600 300MHz \$2859 64/4G/24xCD KB	Power Macintosh® 9600 350MHz \$3439 64/4G/24xCD KB
--	---	---	---	---

PowerBook® 3400 200MHz 240MHz 16/2GB/CD 16/3G/12XCD \$2799 \$3139	PowerBook® 1400 CS/166 16/1.3G/CD C/166MHz 16/2GB/8XCD \$1639 \$1859	SONY 100ES/100GS 15" Monitor .25 Dot Pch \$335/365	SONY 200ES/200GS 17" Monitor .25 Dot Pch \$589/649	SONY 400PS/300SF 19" 20" \$1059/1149
--	---	--	--	--

POWERBOOK®

pwrbk Sale!



Apple eMate 300	729
1400Cs/166	16/1.3G/CD 1639
1400C/133	16/1.3/6xCD Call
1400C/166	16/2GB/8xCD 1859
3400C/180	16/1.3G/12xCD Call
3400C/200	16/2GB/12xCD 2799
3400C/240	16/3GB/12xCD 3139
G3/250	32/5GB/20XCD 4399
DUO 2300C	20/1.1/MDM *1349
2400C/180	16/1.3G 1859

WorkGroup®

WorkGroup Specialist!



6150/66	16/1.2/INTRNT	799
7250/120	16/2GB/INTRNT	999
7350/180	48/4GB/12XCD	2369
7350/180	48/4GB/CD/Intrnt	2795
7350/180	48/4GB/CD/AShr	2979
9650/233	64/4GB/CD/Intrnt	4699
9650/233	64/2X4GB/CD	4949
9650/233	64/2X4GB/CD/AS	5679
9650/233	64/4GB/AS/DAT	5679
9650/350	64/4GB/CD/AS	CALL
500/132	32/CD/BASE	6399
500/132	32/2GB/DAT/CD	7789
700/150	32/1GB/CD	7349
700/150	48/4GB/DAT/CD	9149
700/200	48/2-4GB/CD	10789

SONY

NEW SONY MONITORS



100ES/100GS	15"	335/365
200ES/200GS	17"	589/649
200PS	17"	789
220vs/17SE2	17"	829/839
400PS	19"	1059
300SF	20"	1149
20SE2	20"	1495
500PS	21"	1649
GDM-W900T	24"	3559

HP HEWLETT PACKARD



DeskJet 720CXI	338
DeskJet 890CXi	439
DeskJet 1600CM	1599
LaserJet 6MP	839
Color LaserJet 5M	4799
LaserJet 4000N	1389
LaserJet 4000TN	1549
LaserJet 4MV	2299
LaserJet 5SI MX	3349
ScanJet 6100C	699
DesignJet PLOTTERS	Call

UMAX

Astra 610S	159
Astra 1200S Deluxe	239
Astra 1200S w/full Photo	459
PowerLook II Pro	1269
Mirage IISe/II	3159/6689

GLOBAL VILLAGE

Teleton x2/K56	147
Powerport PC 199	G771 17" 509
Powerport Pro 285	17GA 17" 559
Powerport PCsek 237	17PS 17" 589
Powerport Prosek 339	PT775 17" 589
	G800 20" 995
	P810 21" 1259
	P815 21" 1399
	G810 21" 1199

ViewSonic

15GS 15"	309
15GA-2 15"	365
G771 17"	509
17GA 17"	559
17PS 17"	589
GT75 17"	589
PT775 17"	689
G800 20"	995
P810 21"	1259
P815 21"	1399
G810 21"	1199

WACOM

Art Pad II	129
Artz II 6x8	289
Artz II 12 x 12	399
Artz II 12 x 18	649

TARGA

Targa 2000	2685
Targa 2000 Pro	2899

Apple® Monitors

LOWEST PRICES EVER!



MS 15"	279
MS 15AV	339
MS 1705	529
MS 720	559
AppleVision 750	739
AppleVision 750AV	839
AppleVision 850	1439
AppleVision 850AV	1749

Apple® Printers



StylWrtr 2200	269
StylWrtr 1500/2500	169/209
StylWrtr 4100/4500	237/327
StylWrtr 6500	449
LsrWrtr 8500	2299
LsrWrtr 12/640 PS	1069
LsrWrtr 16/600 W/Tnr	1579
LsrWrtr 12/660Ps Kit	3889

UMAX

C500/200	16/2G/CD/33.6	1095
C600LT/240	24/2GB/CD/33.6	1299
C600VPC/240	32/3GB/CD	1399
C600X/280	32/4GB/CD/33.6	1885
J700L/180	24/2GB/CD/33.6	1689
J700/233	24/2GB/CD/33.6	1839
S900L/200	32/2GB/CD/KB	2289
S900/250	64/4GB/CD/Zip	3299
S900/200	Dual/32/2G/CD	2659
S900/250	Dual/ 64/4g/Raid	6199

EPSON®

Perfection 600 Mac	Call
Expression 636 Exec	709
Expression 636 Artist	895
Expression 636 Proff.	1249
Expression 836XL	2099
Stylus Color 600/800	235/319
Stylus PHOTO/1520	348/719
Stylus Color 3000	1649

AGFA

Arcus II Le/Full	1169/1339
StudioStar LE/Full	749/899
StudioScanIIsi Le/Full	459/589
SnapScan 310/600	199/368
EPhoto Digital Camera	279
Dual Scan	Call

NEC

A500/E500	319/379
A700/E700	565/649
P750	739
E1100/P1150	1229/1359

LinoColor

Lino JADE	469
Lino SAPHIR	1399
SAPHIR Ultra	3299
Lino OPAL	5089
OPAL Ultra	6749

IXMicro

Turbo TV	95
4MB PCI	249
8MB PCI	399

Nikon

ScanTouch	569
CoolScan II	859
Super CoolScan	1639

NEWTON

2100 8MB	899
2000 5MB,KB	799
2MB / 4MB	69/139
Keyboard	79

RASTEROPS

MC620 17"	499
MC7515 19"	899
MC801 21"	1199
MC801HR 21"	1459

MAC TO GO Toll Free! **1-800-946-6221**
 E-Mail: mactogo@knl.com Customer Service: 310.444.1122 Facsimile : 310.444.1130

Gov't, Schools, Fortune 500 P.O.'s Welcome. * denotes Refurb prod. Visa, MC, AMAX accepted. Prices are Cash Discounted for COD Cash/Cashier Check. Prices may change without notice. Limited stock. All Sales are Final.

Best Prices! Lifetime Warranty!

DIMMS

32mb \$ 65 168 pin 64mb \$125

SIMMS

16mb \$ 33 72 pin 32mb \$ 65

All prices are subject to change. Limited to stock on hand.
www.macsolutions.com

(800)873-3RAM

Tel: (310) 966-4444 Fax: (310) 966-4433

CIRCLE 456 ON READER SERVICE CARD

MacBYTE

NO PAYMENT FOR 6 MONTHS!

BUY • SELL • TRADE

- CASH FOR MACS
- NEW & USED MACS
- WITH WARRANTIES
- FEDEX OVERNIGHT SHIPPING

Local Area On-Site Consulting

800-432-2983

4223 Glencoe Ave., Suite C200
Marina del Rey, CA 90292

FAX: 310-448-4494
E-MAIL: MacByte@aol.com

CIRCLE 457 ON READER SERVICE CARD

WHY IS THE COMPETITION SHAKING?

BECAUSE

1•800•4•MEMORY

IS HERE

WE CAN BEAT

ANY QUOTED PRICE ON ANY MEMORY FOR ANY COMPUTER (NOTEBOOK, DESKTOP, PRINTERS) ANYWHERE... PERIOD!

- LIFETIME WARRANTY
- FREE TECH SUPPORT
- NO CREDIT CARD SURCHARGE
- MOST ORDERS SHIPPED SAME DAY

CALL AROUND THEN CALL US

CHECK OUR WEB SITE FOR SPECIALS
WWW.18004MEMORY.COM

We Manufacture **MEMORY**

BUY DIRECT! SAVE MONEY!

DIMMS 5v / 3.3v

32MB \$88 / \$88

64MB \$180 / \$176

SIMMS 72pin SIMMS 30pin

16MB \$48 4MB \$15

32MB \$72 16MB \$50

PowerBooks

3400-32MB \$195 1400-24MB \$167

190-24MB \$160 5300-16MB \$100

G3-32MB \$88

Prices are subject to change

Visit our Website for Complete Up-to-Date Price List
www.apcom.com/acl
www.cybertechmall.com/kpo

A.C.L. INC. 2155 Bering Dr., San Jose, CA 95131

800-888-0348

CIRCLE 461 ON READER SERVICE CARD

A&R COMPUTING 1221 West 6th Street, Suite C, Austin, TX 78703

memory

1-800-832-8802

CALL FOR CURRENT BEST PRICES

WE CARRY 63 MEMORY!

all items are new!

shipping from \$5

TOP quality!

OUR PRICES ARE THE BEST. NO MATTER WHAT'S BEEN ADVERTISED IN THIS MAGAZINE!

lifetime warranty!

prices subject to change

www.arweb.com

VISA • Mastercard • Discover

NO SURCHARGE FOR CREDIT CARDS

M-F 9-7PM
SAT 10-5PM
CST

THE BEST IN REMANUFACTURED Macintosh

COMPUTERS & PARTS

- GENUINE APPLE PRODUCTS AT BIG SAVINGS
- "LIKE NEW" REMANUFACTURED SYSTEMS & PERIPHERALS
- EXCHANGE REPAIR & STOCKING PARTS
- 180 DAY LIMITED WARRANTY
- WE BUY YOUR SURPLUS APPLE PRODUCTS

Pre-Owned Electronics

1-800-274-5343

Offices: 781-778-4600 Fax: 781-778-4848
125 MIDDLESEX TPK, BEDFORD, MA 01730

CIRCLE 460 ON READER SERVICE CARD

does your computer HUNGER for more DATA STORAGE?

NEW 2GB!

omega Jaz 2GB + Cartridge!
int: **\$549** ext: **\$599**

Other Storage Kits

Jaz 1GB + Cartridge	int. \$299	ext. \$379
SyJet 1.5GB + Cartridge	\$299	\$379
Jaz 1GB + 3 Cartridges	\$419	\$469

CD-Recorders

AVD Panasonic 4X/8X CD Recorder
int: **\$429** ext: **\$479**

Other AVD Kits

Yamaha 4X/6X CD-Recorder	int. \$499	ext. \$549
Teac 4X/12X CD-Recorder	\$499	\$549
Yamaha 4X/2X/6X CDRW	\$549	\$599

Recorder Duos

Extreme Panasonic 4X/8X CDR & your choice of Jaz drive or SyJet drive in one unit! **\$829**

Other Extremes

Yamaha 4X/6X + JAZ or SyJET	\$899
Teac 4X/12X + JAZ or SyJET	\$899
Yamaha 4X/2X/6X CDRW + JAZ or SyJET	\$949

CD Duplication

Multidrive Duplication Systems

Mediastore Easy CD-2-CD Duplicator	\$999
MediaFORM CD-2-CD Duplicator	\$2699
MediaFORM 4600 6-CDR Duplicator	\$6999

Autoloader Duplication Systems

MediaFORM 50-CD Duplicator	\$5999
Champion 50-CD Duplicator	\$5999
< Champion 150-CD Duplicator	\$6999

CD-R Blanks

Mitsui GOLD & Verbatim BLUE. Printable, Spindle, CD-RW tool, As Low As **\$1.79**

CD Labeling

Picasso CD COLOR PRINTER

Includes 10 free pieces of printable CDR media!

\$1199

CD Stomper Labeling Kit: **\$49**

Ad Code: BB-104

ORDER TOLL FREE!

800.555.5551

open M-F: 7 a.m. - 6 p.m. (PST) • intl ph. 714-974-5551 • fax. 714-279-1690

Product Prices and Availability Subject to Change

MEDIASTORE
www.mediastore.com

233MHz 604e... ONLY \$299!

SHIPMENT RESCUED FROM UFO—UNBELIEVABLE!

You can get all the speed you need and save thousands of dollars with out-of-this-world upgrade products from Sonnet. Keep your present computer, memory, hard disk, and configuration—simply work faster. Sonnet cards are

fast, inexpensive, easy to install, and 100% compatible with every application, Mac OS 7 & 8. On earth, each product is covered by a one-year warranty and free tech support.



CRESCENDO 604E ACCELERATOR CARDS

Power Mac 6100/7100/7300/7500/7600/8100/8500/8515/8600/9500/9515/9600 • Performa 611X • Workgroup Server 6150/7350/8150/8550/9150/9650 • DayStar • Power Computing • UMAX • Radius



Boost your Power Mac speed up to 240MHz with **Crescendo™** accelerator cards. Just plug in the new card, restart your computer, and prepare to be blown away.

CRESCENDO 180-200MHz 604e \$299
Power Mac 6100 • Performa 611X • Workgroup Server 6150

CRESCENDO 200-233MHz 604e \$299
Power Mac 7100/8100/8115 • Workgroup Server 8150/9150 • Power 100/200 • Radius 81/110

CRESCENDO 233MHz 604e \$299 **CRESCENDO 240MHz 604e \$349**
Power Mac 7300/7500/7600/8500/8515/8600/9500/9550/9600 • Workgroup Server 7350/8550/9650 • DayStar Genesis • PowerWave • UMAX J700/S900



The Crescendo 180-200MHz and 200-233MHz cards automatically adjust to the highest possible processor speed for each Power Mac model.

CACHE PRICES FALL TO EARTH! LOOK!

Power Mac 4400/5260/5400/5500/6100/6360/6400/6500/7100/7200/7300/7500/7600/8100/8500/8600 • Performa 611X • StarMax • Power Computing • UMAX • Radius

Adding a cache card is the most cost-effective way to increase Power Mac performance. A level 2 cache card provides more information to the CPU every bus cycle. Add a Sonnet cache card for even more speed-up to a 200% overall performance increase.

256K LEVEL 2 CACHE \$39 **TMB LEVEL 2 CACHE \$149**
Power Mac 6100/7100/8100/8115 • Performa 611X • Workgroup Server 8150/9150 • Power 100/200 • Radius 81/110

256K LEVEL 2 CACHE \$39 **512K LEVEL 2 CACHE \$69** **TMB LEVEL 2 CACHE \$139**
Power Mac 7200/7215/7300/7500/7600/8200/8500/8515/8600 • Workgroup Server 7250/7350/8550 • PowerCenter, PowerTower, PowerWave

256K LEVEL 2 CACHE \$99 **TMB LEVEL 2 CACHE \$199**
Power Mac 5260 Power Mac with MultiProcessor Card

256K LEVEL 2 CACHE \$39 **512K LEVEL 2 CACHE \$69** **TMB LEVEL 2 CACHE \$199**
Power Mac 4400/5400/5500/6360/6400/6500 • StarMax • UMAX C500, C600, J710

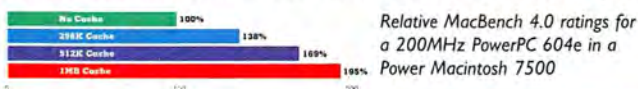

RUN YOUR '030 MAC UP TO 500% FASTER WITH PRESTO 040!

Mac LC/LC II • Color Classic • Mac IIci/IIcx/IIsi/IIvi/IIvx • Performa 250/275/400/405/410/430/600

With a 68040-based **Presto™** accelerator card, you can increase performance by as much as 500%. The Presto 040 80/40 MHz with a 128K level 2 cache for the Mac IIci, IIcx, IIsi, IIvi, IIvx, and Performa 600 is only **\$199**, with FPU **\$299**. (\$49 Adapter required for Mac IIcx and IIsi.) The Presto 040 50/25 MHz for Mac LC, LCII, Color Classic, or Performa 250, 275, 400, 405, 410, or 430 is **\$149**, with FPU **\$199**. Adding a Presto card is the only way to run Mac OS 8.1 on '030 Macs today (LC, IIcx: Mac OS 7 only).



RUN
MAC OS 8.1

DOUBLE YOUR QUADRA SPEED!

Quadra 610/660AV/700/900 • Centris 610/650/660AV • Workgroup Server 60

Plug **QuadDoubler™ 040 100/50 MHz** accelerator into your Quadra, Centris, or Workgroup Server 60 and double your speed for **\$299**. The Centris 610 version runs at 80/40 MHz and is value priced at **\$199**. Compatible with Mac OS 8.1. All QuadDoubblers include an FPU.

RUN YOUR MAC II, MAC LC, LCII, MAC SE, SE 30, OR PERFORMA 400, 405, 410, OR 430 MORE THAN TWICE AS FAST WITH ALLEGRO! STARTING AT \$99



SONNET™
Simply Fast™

800-786-6260
<http://www.sonnettech.com>

Sonnet Technologies, Inc.
18004 Sky Park Circle, Irvine, CA 92614
Tel: 714-261-2800 Fax: 714-261-2461
E-mail: sales@sonnettech.com

No surcharge with Visa and MasterCard. Government, corporate, and education PO.s welcome. One-year limited warranty on all products. All returns require an authorization and are subject to a restocking fee. ©1998 Sonnet Technologies, Inc. Sonnet, the Sonnet logo, Allegro, Crescendo, Presto, QuadDoubler, and "Simply Fast" are trademarks of Sonnet Technologies, Inc.

DMS MAC & PC MEMORY

LIFETIME REPLACEMENT GUARANTEE ON MEMORY PRODUCTS



Data Memory Systems
 24 Keewaydin Dr.
 Salem, NH 03079
 Tel: 603-898-7750
 Fax: 603-898-6585
 E-mail: sales@datamem.com



DMS WILL NOT BE UNDERSOLD ON MEMORY PRODUCTS

- SIMMs •DIMMs •SDRAM •VRAM
- EDO Memory •CACHE
- Printer Memory •Modems
- Network Products
- PowerBook & Notebook Memory Upgrades

Hubs & Connectors

Mac & PC to TV

NewerTECH

28.8Kbps
33.6Kbps
56Kbps!

iomega Zip & Jaz Drives

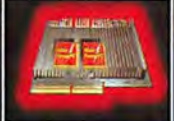

Zip & Jaz Drives & Disks



ORDER ON-LINE 24 HOURS @ <http://www.datamem.com/macworld>

CALL 1-800-662-7466 TOLL FREE

University, Government & Corporate P.O.s with Approved Credit

Shadow Technologies

(800) 4-SHADOW
800-474-2369

PowerBook Memory

PB G3 / 3400
16M/32M/48M/64M/128M
\$66/\$114/\$168/\$219/\$420

168 pin DIMMs
3/3.3V FP/EDO-60 ns
8/16/32MB \$24/37/64
64/128MB \$129/349
SDRAM-10 ns/100 ns
16/32/64/128MB
\$45/69/229/455
G3!!!

PB 2400
8/16/32/64M 2K
\$40/68/119/208

PB 2300 DUO
20M/28M/40M
\$109/\$136/\$215

PB 1400
16M/24M/32M/40M/48M
\$67/ \$95/ \$119/ \$162/ \$189

PB 520/540(c)
16/32M \$65/\$119

PB 160/165/180(c)
6/8/10M \$129/155/179

PB 100 170 sCall

Cache
61/71/8100 256K/1M
\$9 / \$112
72/73/75/76/85/8600
256K/512K/1M
\$38 / \$64 / \$129
44/6360/54/55/64/65
\$45/\$55/\$149
StarMax

VIDEO RAM
256K SIMM \$9
512K SIMM \$14
1M DIMM 72-86 \$19
2M ATI 9500 \$58
2M EDO StarMax \$25
2M SGRAM SMax \$34
4M SGRAM SMax \$52
2M G3 SGRAM \$55
1M G3 SGRAM \$79

Verification of Address Used to Prevent Credit Fraud

Low Price Guarantee: If ANY advertiser offers a lower price on comparable modules (new, late date code, name brand chips) Shadow will strive to BEAT their best price by 2-5%! Call us LAST and SAVE!!

Call for Volume Govt., Discounts Edu, Corp. PO's Welcome

CPUPGRADE
PowerPC Accelerator

SONNET
newer
POWERLOGIX
Best Prices & Shipping is FREE!

Prices subject to change. We notice. Call for updates.

NO SURCHARGE

VISA MasterCard

MEMORY

Lifetime Warranty!
BEST PRICES!
Apple® Authorized Value-Added Reseller

BUY TODAY! Prices Going UP!

168 Pin DIMMs	SIMMs 72 & 30 pin	SDRAM-In Stock!
16/32 mb \$35/65	72 4mb/8mb \$14/17	32/64mb \$65/98
64mb \$125	72 16mb/32mb \$33/65	128mb \$415
64 mb 3-3VEDO \$130	30 2mb/4mb \$10/13	4mb G3 VRAM \$55
PBook 5/53/14/34	30 8mb/16mb \$34/55	Specials
16/32 500 \$68/115	Cache/VRAM	Quantum 2.3 gb \$225
16/24/32 1400 \$68/88/105	61/7100 256k \$12	Quantum 3.2 gb \$260
32/48 5300 \$110/139	44/64/65 512k \$45	Quantum 4.3 gb \$290
32/64 G3/3400 \$105/180	72/86 256k/512k \$40/69	Quantum 6.4 gb \$390
128 G3/3400 \$365	1 mb VRAM \$20	Mac IIci 8mb/o \$99

All prices are subject to change. Limited to stock on hand. #0115

WE BUY, SELL & TRADE MACS!
CALL (800)80-WE-BUY

11933 Wilshire Blvd, West Los Angeles, CA 90025
Tel: (310) 966-4444 Fax: (310) 966-4433
www.macsolutions.com
University & School P.O.'s Welcome
VISA-Discover/MC-AMEX no surcharge

MAC Solutions (800)873-3RAM

Memory & Upgrades

Services Data Recovery • Color Printing • Digital Production

Macworld

SHOPPER

MACS • MEMORY • HARD DRIVES • PERIPHERALS • SOFTWARE • MORE!

Specials!

Viewsonic G771 17" **\$419**
Epson Stylus Color 800 **\$329**

We have a vast selection of Hard Drives and Memory! You must check out our website! <http://www.macstuff.net>

G3 PowerMacs

G3/233 Desktop \$1799
G3/266 Desktop \$2199
G3/266 Tower \$2649
G3/250 PBook \$4799

G3 PowerMac DIMMs

16mb SDRAM \$59
32mb SDRAM \$89
64mb SDRAM \$199
128mb SDRAM \$449

PowerMac DIMMs

16mb \$45 • 32mb \$69
64mb \$129 • 128mb \$399

Digitek

www.macstuff.net
Call Toll Free
1-888-699-8787
School, Government and Corporate POs Welcome
Prices are subject to change without notice.

MEMORY

"Computer Show" Prices Everyday!

Mohawk Memory Co., Inc.
SIMMS • DIMMS • EDO • ECC •
VRAM • CACHE • PRINTER •
SDRAM • POWERBOOK

Fax: (978) 897-0009
Email: simd@mhawkmem.com
Webstore: www.mhawkmem.com
16A Waltham St. Maynard MA 01754
Visa MC Discover AMEX PO's O.A.C.

1(800) 986-6429
Good Old-Fashioned New England Service

MEMORY

64MB DIMM

\$159

WWW MEMORY-TECH.COM

see our site for latest price listing

"A Macworld never goes by without me checking to compare prices. I always look to see if what I need is there."
-Owner, Computer Consultants

Macworld SHOPPER

PROFESSIONAL DATA RECOVERY SERVICES.

Hard Drives, Floppy Drives, Syquest, EZ-135, ZIP, JAZ, Optical & Bernoulli.

TOTAL RECALL

THE DATA RECOVERY COMPANY

800 743-0594 VISIT US AT www.recallusa.com

2462 WAYNOKA ROAD • COLO. SPRINGS, CO 80915 • TEL (719) 380-1616 • FAX (719) 380-7022

CIRCLE 463 ON READER SERVICE CARD

"I always look at the entire Macworld Shopper section to see what is available. I also like to check the prices of all the different products."
-Owner, Computer Consultants

Macworld SHOPPER

Free Shipping Call for details

Digital Output Overnight
PC or Mac

Send PC/Mac files by FTP or Priority Air Express to Imagers and for most output services, your finished work is in your hands the very next morning.

DIGITAL 4 COLOR OFFSET PRINTING

QuickMaster
HEIDELBERG
Print all you need!

indigo
Print only what you need!

Color press proofs overnight. Upon approval, finished job in 24/48 hours. Brochures, Business Cards, Labels, Postcards, Newsletters, Booklets...

IMAGERS
Digital Production Center
INFO & QUOTES on the web
800.672.7029/404.351.5800
1575 Northside Dr., Ste. 490 Atlanta 30318
www.imagers.com

The Data Recovery Experts.

When it comes to recovering your critical data, bigger is better.

Over 40,000 successful data recoveries performed.

- Experts on every operating system and storage media.
- Calls answered 24-hours a day, everyday.
- Emergency & onsite services.

Ontrack
800-872-2599
www.ontrack.com
Mpls • LA • San Jose • DC • London • Tokyo • Stuttgart
©1997 Ontrack Data Recovery, Inc.

Expansive data recovery clean rooms worldwide.

CIRCLE 464 ON READER SERVICE CARD

DATA RECOVERY: 800-440-1904

7 good reasons to choose DriveSavers:

1. We're the most trusted and respected data recovery specialists.
2. 24-hour, onsite, and weekend service available.
3. Proprietary techniques so advanced we retrieve data others might simply abandon.
4. Over 12 years of Macintosh data recovery experience.
5. Certified to maintain most drive warranties.
6. Featured by CNN, NextStep, BBC, C-Net, Forbes.
7. All storage devices: Mac OS, DOS, Win95, WinNT, OS/2, UNIX, Sun, SGI, Novell.

DRIVESAVERS DATA RECOVERY

Clip and save this ad. Visit DriveSavers at: www.drivesavers.com

DRIVESAVERS, INC. 400 BEL MARIN KEYS BLVD., NOVATO, CA 94949, INTL: 415-382-2000, FAX: 415-883-0780

CIRCLE 465 ON READER SERVICE CARD

SELL YOUR PRODUCTS!

Full Color Promo Cards
\$95
500 copies

Create Your Own Full Color Custom Promo Cards To Market Your Products & Accessories • Perfect For Trade Shows, Special Events & More! • Call Now For More Information & A Free Sample Kit!

Modern Postcard™

1-800-959-8365

©1997 Modern Postcard. All rights reserved.

MAC REPAIR

Mac Shop Northwest
WWW.MACSHOP.COM

- Apple™ Certified Technicians
- One-Day Service Turnaround*
- Hard Disk Repair & Data Recovery
- Up to 75% below Dealer Rates
- Component-Level Repairs
- Expert Advice and Prices by Phone
- Power Supplies & Logic Boards*
- Lifetime Repair Warranty*

Tel: 1-503-642-3456

*on many repairs. Visa/MC/AX. Fast overnight shipping available. We use genuine Apple™ parts.



1-800-MAC-SHOP

CIRCLE 467 ON READER SERVICE CARD

DIGITAL IMAGING

- Slides & Negatives \$3.75
- 4x5 chromes/negs \$30
- Large Posters & Displays
- Scanning High & Low Res
- Photo CD Scans & LVT Output
- Short Run 1200 dpi Color Output
- Quantity Prints, Slides, Overheads

Show & Tell 39 W 38th St., NY, NY 10018
212 840 2912 • 212 840 7953 (fax)

CIRCLE 468 ON READER SERVICE CARD

MAC REPAIR & UPGRADE

24 HOUR SERVICE TURNAROUND • LONGER WARRANTY
FREE DIAGNOSTIC • COMPETITIVE PRICE



- * Specialize in component repairs:
• Power Mac • Power Book • Logic boards
- * Advance Exchanges

DT & T

MACINTOSH SERVICES, INC.

800-622-7977

720 East Evelyn Ave., Sunnyvale, CA 94086 • Tel: 408-720-9899 • Fax: 408-720-9459
http://www.dttservice.com

Data Recovery in hours.

- Over 10 years of experience with clients worldwide including Apple, NASA, HP, and FedEx.
- We've recovered more than half-a-million megabytes of Mac Data alone.
- You only pay when there's a recovery.
- Express One-Day Service is available.
- Call 24 hours a day.

415-495-5556 • FAX 415-495-5553 • RESTRICTIONS MAY APPLY
381 Clementina Street • San Francisco, California 94103



LAZARUS

DATA RECOVERY

Working at the speed of business.

800-341-DATA

CIRCLE 469 ON READER SERVICE CARD

Active Buyers turn to the

Macworld
SHOPPER

Over 590,000 Macworld subscribers turn to the Macworld Shopper monthly. 531,250 of these buyers have taken action as a result of seeing an ad in the Macworld Shopper.

Macworld Shopper Purchase Study, 1995

WE SPECIALIZE IN WHOLESALE WATERLESS COLOR PRINTING

1000 FULL COLOR BUSINESS CARDS FOR \$100 Sug. retail price \$179
1000 FULL COLOR POSTCARDS FOR \$149 Sug. retail price \$249

Printed waterless at 300 line screen from your computer files on Super Premium 10pt. Kromekote with our FREE scratch-resistant aqueous coating.



Chicken . Pasta . Ribs
14820 U.S. 19N
Largo, FL 33764

"Since 1977"
FAX (813) 524-1677

Open 11AM Daily
(813) 524-9700

Save Money!
Upload Your Files
to Our FTP Site at
ftp.copycraft.com

- BUSINESS CARDS
- POSTCARDS
- CD INSERTS
- CD TRAY LINERS
- BROCHURES
- BOOKLETS
- NEWSLETTERS
- POSTERS & MORE



FEATURING 300 LINE SCREEN WATERLESS OFFSET PRINTING

Rates for Brochures, Booklets and Flat Sheets are also available.

**4-COLOR
WATERLESS
SPECIAL**

1,000 18" x 24" Posters

Printed from your files on 100 lb. gloss text,
4-Color, full bleed with FREE aqueous coating.

Get 2,500 Posters for only \$1599.

SHIPPING NOT INCLUDED

\$1299

SUGGESTED
RETAIL \$1,999

GRAPHIC ARTS
AVAILABLE



Copy craft
PRINTERS, INC.

4413 82nd Street • Lubbock, TX 79424 • FAX: 806.794.1305

QUARK
Authorized
Service Bureau

Factory Authorized
COREL
Service Bureau

Email your requests for printing quotes to request@copycraft.com

1.800.794.5594

CALL TODAY FOR A **FREE** COPY OF OUR **NEW** FULL COLOR CATALOG

Visit <http://www.copycraft.com> for more 4-Color Specials!

CIRCLE 470 ON READER SERVICE CARD

DIRECTORY

DIRECTORY CONTACTS 800.825.4237

ADVERTISING REPRESENTATIVES

Spencer Frasher sfrasher@ztd.com x5864
Michelle LeWinter mlewinte@ztd.com x5122
Kristin Newman knezman@ztd.com x5862
Jessica Turko jturko@ztd.com x5140

ADVERTISING SALES MANAGER

Monifa Kelly mkelly@ztd.com x5155

DIGITAL AD COORDINATOR

Brian Mullin brian_mullin@macworld.com

(415) 267-1735

ACCOUNTING SOFTWARE

COMPLETE BUSINESS SOLUTIONS

One-stop shop for hardware, software, financing and services for any size business. Our accounting programs range from basic to sophisticated multi-user systems plus Point of Sale, Inventory, Invoicing and Payroll packages. Call for a catalog or e-mail us at info@maxworld.com.

MAX COMPUTERS • (800) 656-6299

1506 25th Street, San Francisco, CA 94107
http://www.maxworld.com/accounting • Fax (415) 695-0257

CIRCLE 471 ON READER SERVICE CARD

ACCOUNTING/POS SOFTWARE

DB:\$ RETAILER'S ADVANTAGE

POINT OF SALE • ACCOUNTING & MORE
Full demo available for fast POS/Inventory Management
Single or Multiple User(s) and Store locations
Includes POS, Order Entry, Receivables, Inventory, PO, Payable

DB:SOLUTIONS, INC.

929 Sir Francis Drake Blvd. C-238 Kentfield, CA 94904
www.posbydbs.com • eMail: sales@posbydbs.com
Toll Free: 888/461.9501 TEL: 415/461.9500 FAX:
415/461.9501

BUSINESS CARDS

FULL COLOR BUSINESS CARDS

For Resale: Get the full spectrum of colors at 2400 dpi
for only \$89.00 for 1,000.

Price includes: Design, Shipping, & Delivery to your door.

Stock weight: 12pt. coated; screen res. stochastic

COLOR VISION BUSINESS CARDS

1-800-475-9332
WWW.COLORV.COM

CIRCLE 473 ON READER SERVICE CARD

CD ROM

CD-ROM Production Services

- All formats: Mac, ISO, Hybrid, Mixed Modes
- Premastering, beta testing, or archiving
- Mass Replication available, any quantity
- Personal, Knowledgeable Service for 10 Years!
- Certified Apple Developer • Low prices/fast delivery

NORTHEASTERN DIGITAL RECORDING

2 Hidden Meadow Ln, Southboro, MA 01772
508-481-9322 Fx:508-624-6437 CDNDR@aol.com

COMPUTER INSURANCE

INSURES YOUR MAC

The ComputerownersSM insurance policy repairs or replaces hardware, media and purchased software. \$49 a year covers up to \$2,000 of equipment against theft, fire, accidents, power surge, natural disasters and more! \$50 deductible. Call for immediate coverage or information. 1-800-800-1492.

SAFEWARE, The Insurance Agency, Inc.

5620 N. High Street, PO Box 656
Columbus, Ohio 43085

CIRCLE 475 ON READER SERVICE CARD

DISK DUPLICATION

CD-ROM MASS-REPLICATION

- Quantities from 500 discs to 10,000,000 +
- ISO 9000-certified manufacturing
- Complete, innovative printing & packaging: cardboard, Tyvek®, & jewel-box packaging options available.

OASIS® DUPLICATION

micah@oasiscd.com • 800/697-5734
Fax 540/675-2500 • FLint Hill, VA 22627

CIRCLE 476 ON READER SERVICE CARD

DRIVE SALES & REPAIRS

FLOPPY DRIVE REPAIR & SALES

Mac 3.5" 400k, 800k, & 1.44 MEG .(Repair) . . . \$40.00
Advanced Exchange From \$40.00
New & Refurbished Hard Drive & Floppy Drive Sales. . . Call
Price includes most parts, cleaning & alignment. 1yr
warranty on repair, 2yrs on new drives. Schools & Gov't.
PO's accepted. Expert Data Recovery.

UPTIME COMPUTER SUPPORT SERVICES

http://www.scvnet.com/~uptime • 23633 Via Primo
Valencia, CA 91355 • 805-254-3384 • Fax 805-254-1950

CIRCLE 477 ON READER SERVICE CARD

GENEALOGY SOFTWARE

REUNION® 5- New upgrade!

"SPECTACULAR" ★★★★★ MacWorld, 1/98. Sound & video, Web publishing, drag-and-drop editing. Unlimited individuals, events, facts and sources. Create large wall charts: Ancestor and Descendant, plus new Relative and Timeline charts with photos - great for family reunions. To order, call MacWarehouse 800-255-6227. Visit our Web site: www.LeisterPro.com

LEISTER PRODUCTIONS, INC.

P.O. Box 289 Mechanicsburg, PA 17055
tel: (717)697-1378 • e-mail: info@LeisterPro.com

CIRCLE 478 ON READER SERVICE CARD

LEATHER MOUSE PAD

High Performance Leather Mouse Pad

Pad with soft leather surface on a non-skid natural rubber base. Mouse sinks deeper into pad for better contact, easy to keep clean, edge will not fray, looks and feels great. 9 1/2" X 8". Available in black & brown. Price 14.95 + 3.50 S&H Visa/MC

S.R. SIKES COMPANY

P.O. Box 26095 Minneapolis, MN 55426
(888) 433-6142 Fax (612) 931-9905

CIRCLE 476 ON READER SERVICE CARD

RELIGION

Bible Study on Disk or CD-Rom

Full Featured. Fast & Friendly Bible study software. As the leader in Bible study software since 1981 we have continued to listen to our customers and provide them with the tools they need. Call for a FREE catalog. http://www.brs-inc.com/bible

BIBLE RESEARCH SYSTEMS

2013 Wells Branch Pkwy. #304, Austin, TX 78728
(800) 423-1228 (512) 251-7541

CIRCLE 479 ON READER SERVICE CARD

We Take Product Testing
Seriously.



Introducing a NEW Service to Macworld Readers...



www.macworld.com/getinfo

Macworld's **NEW** **ONLINE** Reader Service

Introducing Get Info. Now you can get information on all the products and services you see in *Macworld*. Only get it faster. Simpler. Better. Now. All you have to do is visit one Web site:

www.macworld.com/getinfo

Then select the products, product categories or advertisers for whom you want to receive information.

That's it. You can have the information delivered to you by e-mail, postal mail or even telephone. Or you can click on a link that will take you straight to the vendor's Web site in one easy step.

It's quick. Convenient. Fast. So next time you're interested in a product, don't get a stamp. Get Info.

Macworld

The Macworld **Lab.**

In fact, we think product testing is so important to helping Macworld readers make the right buying decisions, only Macworld has . . .

A **New** Lab

State-of-the-art showcase of Macworld's testing prowess. Built from the ground up for more product tests and head-to-head shootouts.

Cross-Platform Benchmarks

To help readers deal with integrating Macs with Windows NT, and the issues of interoperability.

Continued Development of **MacBench**

The industry's only publicly available benchmark tool for CPU, graphics cards and storage devices.

Further Enhancements to **SpeedMark**

The standard for real world application-based Mac performance tests.



Divine information.
Sent from the high tech heavens.
Your day-to-day just got a whole lot easier.



The Bible Series— from IDG Books Worldwide

100% Comprehensive. 100% Authoritative. 100% of What You Need to Know

The Bestselling Bible Series is Loaded with Features:

- ➔ Expert authors—including many software trainers and consultants
- ➔ A-to-Z coverage of high tech topics—from software programs to Mac programming
- ➔ Easy-to-read format—complete with helpful charts, tables, and step-by-steps
- ➔ A Bonus CD-ROM—packed with time-saving and entertaining programs personally selected by the author!
- ➔ Bibles cover all the hottest topics!
 - Macworld® Photoshop® 4 Bible
by Deke McClelland ISBN: 0-7645-4005-X \$49.99 w/ CD
 - Macworld® Illustrator® Bible
by Ted Alspach ISBN: 0-7645-4027-0 \$39.99
 - Macworld® FreeHand™ 7 Bible
by Deke McClelland ISBN: 0-7645-4015-7 \$39.99
 - Macworld® Mac® OS 8 Bible
by Lon Poole ISBN: 0-7645-4036-X \$34.99

Check Out These Other Magnificent Mac Titles from IDG Books!

- Macworld® Mac® Secrets®, 4th Edition
- Macs® For Dummies®, 5th Edition
- Mac® OS 8 For Dummies®
- Mac® OS 8 For Dummies® Quick Reference
- Macworld® PageMaker® 6.5 Bible
- Macworld® Photoshop® 4 Instant Expert
- Mac® Programming For Dummies®, 2nd Edition
- Macs® For Kids & Parents™
- Macworld® ClarisWorks® Office Bible
- Macworld® QuarkXpress® 4 Bible

Pick up a copy
at your favorite
bookstore or
software store
or call 800.762.2974
(24 hrs. a day, 7 days a week)

or order from
www.idgbooks.com

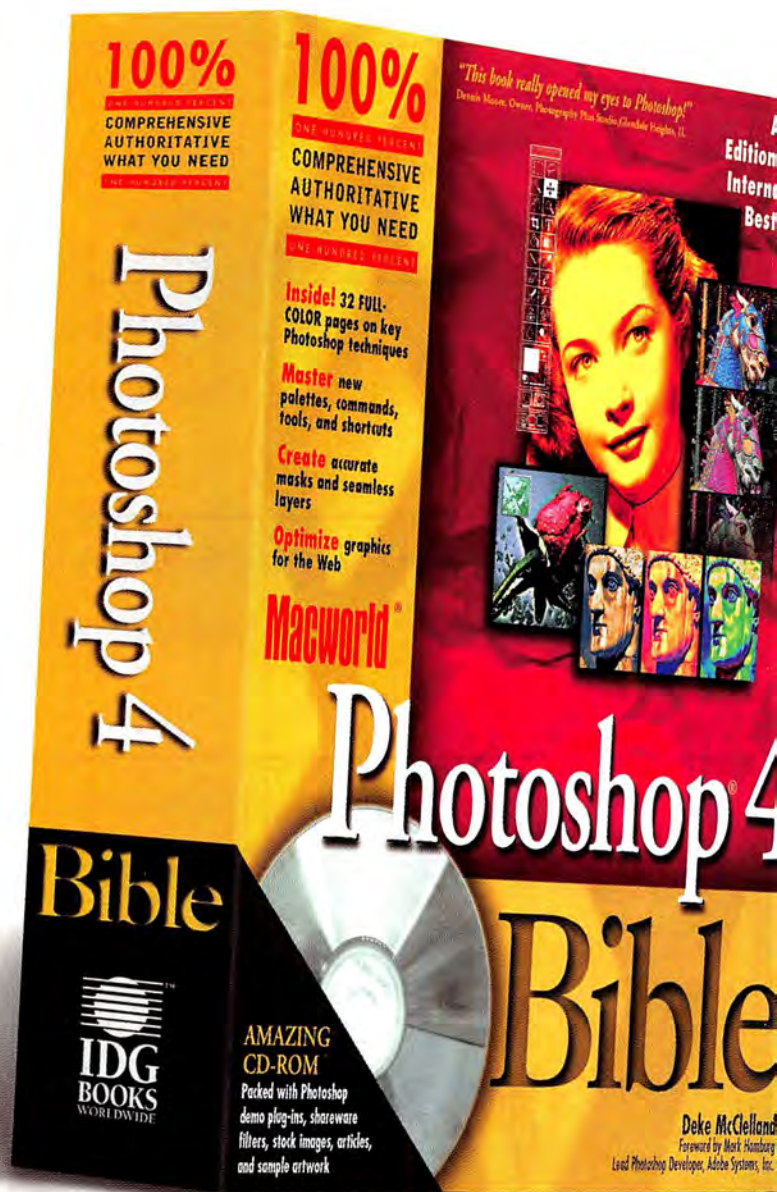

For information on volume order discounts
(25 or more copies) call Andrea Lopez at 650.655.3090

continued from page 178

Now I know. ComputerESP (www.computeresp.com) tracks thousands of prices for computer gear—and shows you a list of mail-order outfits' prices for your item, sorted by price. Although I have much nostalgic affection for Mac Warehouse and its ilk, I'd rather not foot the bill for their weekly catalogs by paying higher prices. For example, compared with the best prices listed on ComputerESP, MacMall charges \$20 more for RAM Doubler/Speed Doubler, \$18 more for a Global Village 56K modem, and \$100 more for a PowerBook 2400.

Amazon.com

Surprising Book Economics 101: of the \$20 you pay for *Macs for Dummies*, a sumptuous 65 cents winds up in my bank account. Where does the other \$19.35 go? Some to the publisher, of course, but 50 percent or more goes to the bookstore.

Amazon.com, the Web's largest bookstore, doesn't have to pay for a storefront, Muzak, or a coffee bar. Therefore, it can afford to play with that fat profit margin in clever ways. Some goes to the customers as 20 percent off every book.

But the real genius of Amazon lies in its Associates program. If you, as an Amazon Associate, direct somebody from *your* Web site to Amazon's site, you get a check for 15 percent of whatever book that person buys. In other words, if you buy a copy of *Macs for Dummies* by way of my Web site, I get \$2.40 from Amazon *in addition* to my 65-cent royalty! Another win-win-win for the Web: we book authors quintuple our earnings per book, readers save 20 percent, and Amazon gets hundreds of grass-roots Web sites funneling customers its way.

Now you know why every author on the planet has suddenly cropped up with a Web site. But here's a little secret: *anyone* can sign up for the Associates program. It costs nothing, and there's no downside. Are you listening, entrepreneurs?

E-banking

Stay with me here: when do you pay your bills? If you pay the day they arrive in the mail, whomever you're paying gets your money *today*, even though it's not technically due for several weeks. That money could have been sitting in your bank account, earning interest. But if you wait

until just before the due date to mail the check, timing becomes critical; miss the deadline and you're charged late fees.

If you pay your bills electronically, though, using Intuit's Quicken or your bank's Web site, you *input* the payment whenever you want but the check won't get *sent* until the date you specify. Suppose your mortgage, credit-card, utilities, phone, cable TV, car-loan, and Internet bills total about \$3,500 a month. Assuming 5 percent interest in the bank, in the three weeks between a bill's arrival and the due date, that \$3,500 could have racked up \$10.02 in interest! Yes, \$120 a year is what you *give away* to those money-grubbing corporations if you pay promptly to get the bills off your mind.

Actually, you save more than \$120 by doing your bills electronically—you're also spared the hassle of writing checks, stuffing envelopes, and so on. That's handy to remember, because as far as I'm concerned, time isn't just money—it's *time*. **m**

DAVID POGUE (www.poguem.com) is the editor of *The Microstoth Joke Book* (Berkley Books, 1997).

April 1998, Volume 15, Number 4 Macworld (ISSN 0741-8647) is published monthly by Mac Publishing, L.L.C. Editorial and business offices: 901 Second St., San Francisco, CA 94107, 415/243-0505. Subscription orders and inquiries should be directed to 303/665-8930. Subscription rates are \$27 for 12 issues, \$54 for 24 issues, and \$81 for 36 issues. Foreign orders must be prepaid in U.S. funds with additional postage. Add \$18 per year for postage for Canada and Mexico subscribers. Add \$69 per year for postage to all other countries. Periodicals postage paid at San Francisco, California, and at additional mailing offices. Postmaster: Send address changes to Macworld, P.O. Box 54529, Boulder, CO 80328. Printed in the U.S.A.



The graphic features a hand pointing at a computer screen with various colorful geometric shapes and lines in the background. The text 'Buy smart with Macworld Lab.' is prominently displayed in white and yellow.

MACWORLD LAB TEST

Macworld
LAB TEST

To buy smart when you're choosing Mac OS hardware or software, you've got to put it to the test. Macworld Lab is on the job, testing, scrutinizing, and evaluating the performance and quality of the products you need. With real-world testing, we measure performance by real-life standards. Using the system and applications you'd use to complete the tasks you're faced with every day, our experts come up with answers that matter to you.

You can rely on Macworld Lab Test results—We test the products the way you use them.

Macworld
THE ESSENTIAL MACINTOSH® RESOURCE

The Cheapskate's Guide to the Web

FIVE WEBBY WAYS TO HOLD ON TO MORE OF YOUR MONEY

I WAS A LATE BLOOMER ON the World Wide Web. What did I want with chat rooms, games, and *Dilbert* cartoons? As far as I could see, they're just glorified time-killers—the last thing a freaked-out-busy, deadline-chasing, Type-AAA personality like me needs. Aimlessly cruise the Web? Are you kidding? Listen, the last movie I saw in a theater was *Kramer vs. Kramer*.

But a couple of years ago, a funny thing happened: clever entrepreneurs began setting up shop on the Web—not just glorified mail-order catalogs, but businesses that *depend* on the nature of the Web. These companies slash middlemen and markups out of the marketplace, making a profit while still saving the customers money.

These remarkable Web sites intrigue me for two reasons. First, they save me time. (*Yes!*) Second, these sites seem to make everybody money at nobody's expense. Whenever I'm offered a way to keep more of mine, I go for it.

I recently tallied the savings I'd accrued by doing things on the Web: more than \$5,000 in the last two years. I'd be shirking my duties as a Mac reporter if I didn't share my findings.

Auto-By-Tel

In 1996 I wanted to buy a Honda Civic. I went to the local dealer. "Oh, you want a Civic, do ya?" said the guy. "And I suppose you'd also like us to throw in a couple front-row Superbowl tickets? HAW haw haw haw!"

When his hilarity subsided, he explained that the Civic was such a hit in Europe that Honda was getting an extra \$2,000 per car there, making Civics practically unavailable in the States. But he did offer to let me add my name to the waiting list—if I agreed to pay \$1,000 *over* the sticker price.

When Honda dealerships No. 2 and

3 gave me the same story, I was ready to try anything. I gingerly snuck over to www.autobytel.com. For a skinflint like me, Auto-By-Tel's scheme is nearly irresistible: You indicate the car you want to buy, complete with options. The nearest participating car dealer (there are 2,600 nationwide) e-mails you back with a cut-rate offer. There's no charge for any of this—and no obligation to accept the offer. It sure seemed no-lose to me.

Sure enough, two days later, a dealer 30 minutes away wrote me. "Unfortunately, '96 Civics are in extremely short supply," his message said. "The best we

can offer you is \$1,200 under sticker price." I blinked in happiness. Ah, bliss! Ah, savings! Ah, revenge!



can offer you is \$1,200 under sticker price." I blinked in happiness. Ah, bliss! Ah, savings! Ah, revenge!

When I picked up the car, it got better. Since there was no haggling, the dealership guy was friendly and congratulatory instead of phony and predatory. Now *this*, I thought, is the way to buy a car.

Auto-By-Tel makes money by charging a fee to each participating dealer. The dealers make money by receiving hundreds of ready-to-buy customer names off the Web. And you save money because your price doesn't reflect advertising, test

drives, sales commissions, and so on. My only regret is that I didn't think up Auto-By-Tel first.

United Computer Exchange

You can't buy just one Mac in your lifetime; sooner or later, you'll want to upgrade. But how do you sell your outgoing Mac? If you sell locally, you worry that someone out in America-land might have paid more. As for Internet classifieds, how can two strangers be confident that the computer will show up or that the check won't bounce?

United Computer Exchange (www.uce.com) solves both problems

by handling the transaction for you. In exchange for a commission of 10 to 15 percent (paid by the buyer, based on selling price), the company advertises your Mac to the entire Internet population and forwards offers to you. When you accept a bid, UCE receives your computer, cleans it up, checks it out, and ships it on to the buyer. The buyer has two days to inspect the machine; if all is kosher, the deal goes through. Buyer and seller are both protected.

The only thing better than selling a Mac via UCE is buying one there. You get a great education in pricing: for exam-

ple, asking prices for a Power Mac 7100 range from \$600 to \$1,500. Makes you shudder to think: if you didn't have a *national* Web database to scan, you might have been the poor slob who thought \$1,500 was the going rate.

ComputerESP

I used to break out in hives when buying mail-order computer stuff. How could I be sure I was getting the lowest price? Surely some store, somewhere, was selling this item cheaper.

continues on page 177



MultiSync E Series monitors.



*VIS stands for viewable image size. MultiSync and Cromaclear are registered trademarks and E500, E700, E1100, "Expect more. Experience more." and the NEC Technologies icon are trademarks of NEC Technologies, Inc. All other trademarks or registered trademarks are the property of their respective holders. ©1998 NEC Technologies, Inc.

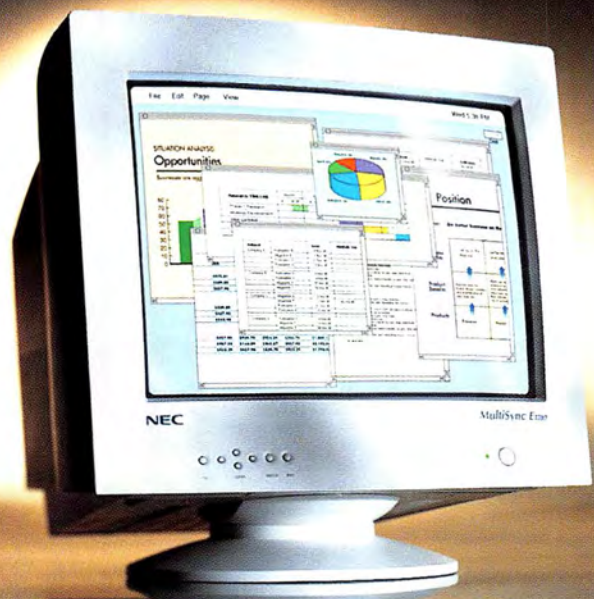

• ANALYST •

• MANAGER •

Enhanced performance for e

Massive word processing? Mammoth spreadsheets? Momentous



presentations? The back nine at St. Andrews?

The performance driven MultiSync® E Series monitors can help. They

	CRT/VIS*	Max Res	CRT Type	Pitch
MultiSync E500™	15"/13.8"	1280 x 1024 @ 65Hz	CROMACLEAR®	0.25mm mask
MultiSync E700™	17"/15.6"	1600 x 1200 @ 65Hz	CROMACLEAR	0.25mm mask
MultiSync E1100™	21"/19.8"	1600 x 1200 @ 65Hz	Dot Trio	0.28mm dot (0.24mm horizontal)

Each MultiSync E Series monitor is compatible with PC and Macintosh® computers, includes digital OSM™ on-screen controls and features a 3 year limited warranty.

For more information or for a reseller near you, call 1-800-NEC-INFO or visit us at www.nec.com. Expect more. Experience more.



• VP •

• CHAIRMAN •

every stage of your career.

provide the superior, lifelike, color saturated images and super high resolutions and refresh rates to handle all your critical business applications. And they do all this with

the MultiSync quality only NEC Technologies can deliver. Qualities any busy business person can appreciate, no matter where you fit within your company's organization chart.



Circle 16 on reader service card



Orbit. Out of this world comfort and control.

Tired of that same old mouse? Want to go where no one has ever gone before?

Orbit is a new kind of trackball that combines the comfort of a mouse with the control of a trackball.

Orbit comes with Kensington's award-winning MouseWorks software. So you can save time with our unique MouseWorks Button, cut down on your

repetitive mouse tasks with Pop-up Menus, even change the cursor speed to match the way you work.

What's more, you get Kensington's legendary Satisfaction Guarantee. That means a 5-year warranty, toll-free technical support, and a no-risk 90-day trial.

For more information, call 800-535-4242, or visit our web site at www.kensington.com.

 PC Connection
1-800-986-2259

 MacWAREHOUSE
1-800-255-6227

**KENSINGTON**
www.kensington.com

 The Mac Zone
Your Calmly Superior

 MacMail

 APS
Technologies
1-800-374-5681

Orbit and MouseWorks are trademarks and Kensington is a registered trademark of Kensington Microwave Limited. All other trademarks are the property of their respective owners. © 1997 Kensington Microwave Limited.

Circle 12 on reader service card